

Bauer Resources

Products and applications

for water well construction and geothermal energy

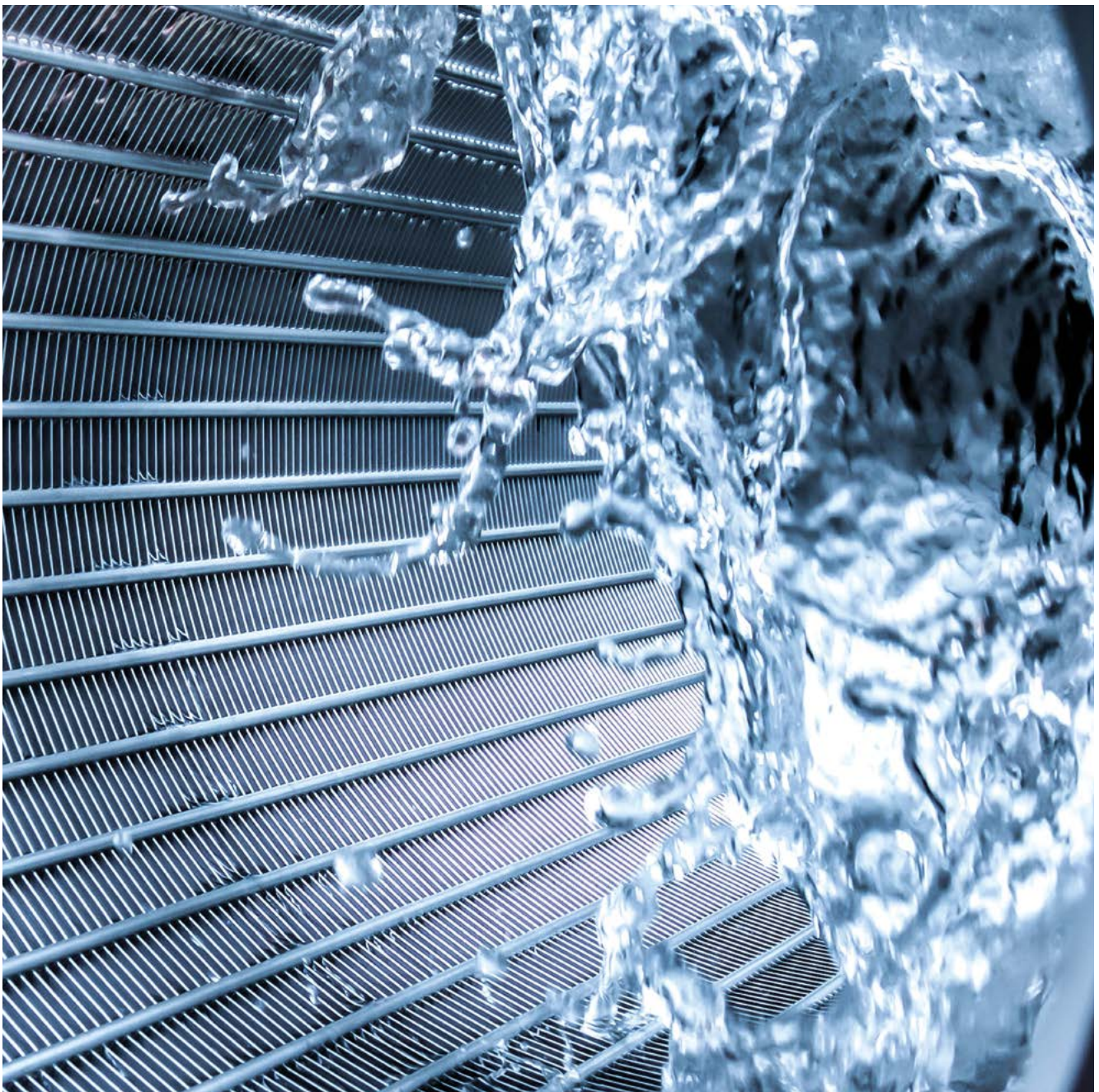

Passion for Water

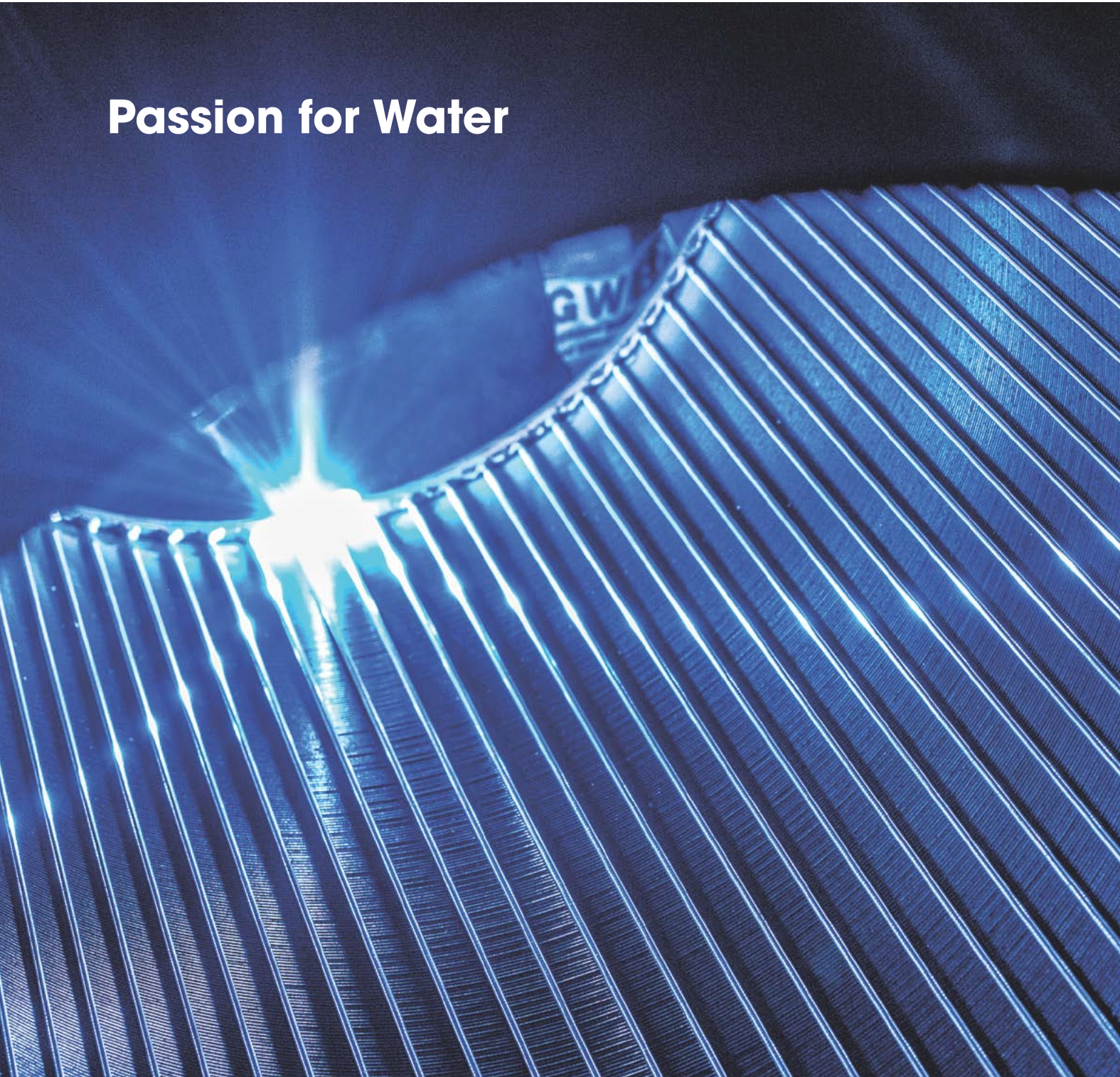

Dear business partners,

over the last several years, the subject of water has become increasingly more important. It is a ubiquitous topic in public discourse. New solutions and approaches are required, and we would like to assist you with our innovative products.

Water is our passion.

In this catalog, we present our multifaceted range of products to you. Our product catalog should help you get started quickly, and of course we are also available to offer you personal advice with your projects.

If you have questions, you can reach us using the contact details you are already familiar with, either centrally by phone at +49 5171 294 0 or by email at info@gwe-gruppe.de. You can access the latest information at any time at www.gwe-group.com.

Markus Hollmann
Chairman of GWE Executive Board

Contents

GWE Group	2	4. Fiberglass	98	9. Geothermal energy	220
Foreword	2	Specialist knowledge	100	Product overview	222
History	6			Specialist knowledge	224
Production and locations	8	5. Submersible pumps	102	Compact shafts	226
1. PVC well materials	10	Product overview	104	Shafts for commercial use GEO shafts	228
Product overview	12	Specialist knowledge	106	GWE geothermal energy special shafts	235
Specialist knowledge	14	GWE is SUB FACTORY for Grundfos	108	GWE EWS duplex probe	236
Screen pipes and casings made of PVC-U	16	GWE 4"-12" submersible pumps	110	GWE OptiFlow® N	238
Gravel pre-packed screens	20	GWE 4" submersible pump with geothermal range motor	116	Accessories	239
TNA casings and screen pipes	21	GWE high-efficiency submersible pump system	117	10. PE pipe systems	240
GWE NORESTA®	24	GWE sampling system MP 1	118	Specialist knowledge	242
GWE NORIP®	28	Centrifugal pumps	119	Rods and coils for drinking water	244
PVC wire-wrapped screen	30	ROBU submersible motor pumps	120	GWE PEHD screens and casings	245
VALUE PVC screen pipes and casings	32	HONDA used water and wastewater pumps	139	11. Hand and solar pumps	246
Lowering screens and solid pipes	34	GWE Monitoring & Control System (MCS)	144	Product overview	248
Special pipes	35	Accessories	146	Specialist knowledge	250
PVC well heads	44	6. Grouting material and sealing clays	150	Hand pumps	252
Fire extinguishing wells	45	Product overviews	152	Emergency hand pump KARDIA® 2000	258
Accessories	46	Specialist knowledge	156	GWE solar pumps	261
2. Steel well materials	50	Sealing clays	158	12. Irrigation	264
Product overview	52	Bentonite-clay slurry	166	Agricultural irrigation	266
Specialist knowledge	54	7. Drilling fluids	176	Garden irrigation - Rain Bird	268
Well materials made of stainless steel	56	Product overview	178	13. Installation accessories	270
Well materials with HAGULIT® coating	64	Specialist knowledge	180		
Bridge slotted screens for dewatering	67	Bentonite	182	14. Services	272
Installation tools	68	Polymers	187	Specialist knowledge	274
➔ For well heads see Well covers section, Page 194		8. Well covers	190	Design calculations	274
➔ For accessories see Well covers section, Page 200		Specialist knowledge	192	Flushing service	274
3. Pump riser pipes	70	Well heads	194	Installation service	274
Product overviews	72	Formed parts and pipe accessories	200	3D design	274
Specialist knowledge	76	Well shafts made of reinforced concrete	206	Pump service	275
Pump riser pipes stainless steel	78	Well shafts made of stainless steel	209	Training based on W 120	275
Pump riser pipes plastic	88	Well houses	210	Stainless steel staining plant	275
Pump riser pipes with coating	90	Well hoods	212	➔ For GWE Monitoring & Control System (MCS) see Submersible pumps section, Page 144	
➔ For formed parts see Well covers section, Page 200		Accessories for well shafts and well houses	216		

History

1920

GWE's origins begin with a retail store opened by Mr. Boese in 1920 in Hannover, Germany



1936

Formation of Schönebecker BrunnenFilter (SBF, Schönebecker Well Screens) as a wholly-owned subsidiary of the company Preussag



1953

Purchase of shares and acquisition by Mr. Nelke. At this point, pumps are also included in the product range, resulting in the name pumpenboese

1960s

In the 1960s, Gerd Nelke acquired the company pumpenboese from his father and significantly expanded business operations in Burgwedel, Germany

1960s

Production of steel products and specialties such as HAGULIT® and rubber-coated casings at HAGUSTA in Renchen, Germany

1960s

Continuous expansion of the product range:

- Production of PVC well screens und hand pumps
- Landfill dewatering and degassing pipes

1989

Acquisition of the production facilities in Luckau (Brandenburg) and Nordhausen (Thuringia), Germany

1989

PVC production in Peine, Germany, with the first fully automated production facility, owned by SBF

1998

pumpenboese and PREUSSAG Wasser & Rohrtechnik merge to form the GWE Group







2007

GWE Group is acquired by BAUER AG and integrated into BAUER Resources GmbH



2020

Formation of foreign subsidiaries, internationalization, expansion of the project-based business

100 years of GWE



Initially founded in 1920 by Mr. Boese as a simple retail shop in Hannover, the following years saw pumpenboese (which now included pumps in its product range) expand as a result of Mr. Nelke purchase of shares and acquisition of the company.

At the same time, Schönebecker BrunnenFilter (SBF, Schönebecker Well Screens) was founded in 1936 as a subsidiary of the company Preussag. From the beginning, Preussag opted for in-house production of, for example, well screens, dewatering pipes, and hand pumps. The company HAGUSTA in the city of Renchen was also part of Preussag and was responsible for the production of steel products. After the Second World War, the company's main headquarters was moved to Peine.

In the 1960s, the most influential person in pumpenboese's 100-year history took the helm: Gerd Nelke. He further expanded the company's business operations and it became, with its headquarters in Burgwedel in Lower Saxony, a direct competitor of Preussag. Following Germany's reunification, pumpenboese acquired production facilities in Luckau (Brandenburg) and Nordhausen (Thuringia).

In 1998, an event occurred that had been unthinkable up to that point. The company pumpenboese seized an opportunity to acquire Preussag, their largest competitor. Practically overnight, professional competitors became freshly minted colleagues. The GWE Group was born.



In the years following the turn of the millennium, the Group went international. GWE expanded and subsidiaries were founded both within Europe and beyond. International projects gained increasing importance.

In 2007, BAUER AG (Schrobenhausen, Germany) acquired the Group. Since then, GWE has been an integral part of BAUER Resources GmbH. With backing from the BAUER Group, GWE is in an ideal position to continue making the best possible use of their extensive technical expertise, both now and in the future.



Gerd Nelke (Owner of the GWE Group), Prof. Thomas Bauer (CEO of BAUER AG), Hiltrud Nelke and Prof. Dr. Reiner Homrighausen (GWE Managing Director) (from left to right, in 2007)

Production and locations

Germany

GWE Headquarters, Peine Administration, sales, application technologies, central logistics



All-round provider in the water well construction sector – as developer, manufacturer, and service provider!
Comprehensive solution systems – customized by tradition!

GWE Nordhausen Focus: Steel and stainless steel



Customized products for projects worldwide!
Stainless steel products are produced in the highest quality and with maximal technical expertise.

GWE Luckau Focus: PVC and PE



Modern extrusion machinery and e-welding technology for optimum product quality.
Efficiency and customer-centered processed for innovative solutions.

Europe and the world

GWE Budafilter
Hungary, Focus: PVC and PE



GWE Pol-Bud
Poland, Focus: Steel and specialty products



GWE France
France, Focus: PVC and PE



GWE Tubomin
Chile, Focus: Steel and PVC











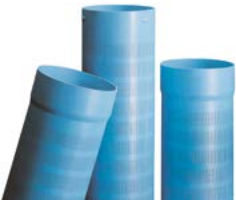

1. PVC well materials

Product overview	12
Specialist knowledge	14
Screen pipes and casings made of PVC-U	16
Gravel pre-packed screens	20
TNA casings and screen pipes	21
GWE NORESTA®	24
GWE NORIP®	28
PVC wire-wrapped screen	30
VALUE PVC screen pipes and casings	32
Lowering screens and solid pipes	34
Special pipes	35
PVC well heads	44
Fire extinguishing wells	45
Accessories	46



Access current information about
the product area online

PVC well materials

	Lowering screen	Value PVC	TNA	DIN	Wire-wrapped screen	SBF Norip®	NORESTA®	NORESTA® 2.0
Product	 DN 200–400	 DN 50–400	 DN 80–400	 DN 35–600	 DN 50–300	 DN 50–125	 DN 100–400	 DN 300–400
Product type	Casing and screen pipe	Casing and screen pipe	Casing and screen pipe	Casing and screen pipe	Screen pipe	Casing and screen pipe	Casing and screen pipe	Casing
	Longitudinal slot	Transverse slot	Normal, thick and extra thick		DIN thread	Pressure-tight threaded double spigot socket connection	Pressure-tight ZSM double spigot socket connection	Pressure-tight spigot socket connection with spigot socket glued on one side and double O-ring seal
	Glued socket	Glued socket	Non-protruding trapezoidal thread	Socketed trapezoidal or pipe thread				
	Without KTW (drinking water plastic approval)	Without KTW (drinking water plastic approval)	KTW (drinking water plastic) approval	KTW (drinking water plastic) approval	KTW (drinking water plastic) approval	KTW (drinking water plastic) approval	KTW (drinking water plastic) approval	KTW (drinking water plastic) approval
Application	Temporary well for dewatering and lowering groundwater level during construction activities	Temporary well for dewatering or process water supply without requirements for water quality	Pipework for insertion in existing wells or for the expansion of narrow boreholes. Installation depths up to 100 m, 200 m and 300 m, depending on wall thickness	Well for drinking water supply. Installation depths up to 100 m, 200 m and 300 m, depending on wall thickness; system with seal	Screen pipe for increased water needs and geology with fine sand. Installation depths up to 100 m, 200 m and 300 m, depending on wall thickness	Quality groundwater measurement points for monitoring, measurement and preservation of evidence regarding groundwater quality	Wells of all types for maximum installation depths with increased leak tightness requirements	Wells with PVC/steel combination expansions from DN 300 to DN 400
Product benefits	Value for money	Value for money	External diameter	Load-bearing capacity	Filter capacity	Pressure-tight	Pressure-tight, easy installation	Pressure-tight, high load-bearing capacity, easy installation

PVC-U as material in water well construction

Products for well construction are subject to the strictest quality requirements. They need to be specially designed for the particular demands of water well construction and at the same time deliver good value for money.

As a material, PVC offers the ideal prerequisites. It is absolutely corrosion-resistant, easy to process, lightweight and features excellent strength properties. The nearly unlimited useful life of this material means that well materials made from PVC offer high economic efficiency.

The time saved for installation of the products is achieved by using components that are coordinated to one another. A complete range of accessories and suitable installation tools ensure fast and professional installation of the products.

At GWE GmbH, screens and casings for well construction are manufactured according to the standards and DVGW rules and standards for water well construction. On request, we are happy to present the relevant certificate of compliance in accordance with DIN EN ISO 10204.

Chemical characteristics

The chemical resistance of products made from PVC is extremely high. PVC pipes can resist all types of groundwater, seawater, brine and even diluted acids and bases during long-term use. Even repeated treatment with regeneration and disinfection agents will not negatively impact the well construction products.

Compliance with the authoritative hygiene requirements is regularly audited by renowned laboratories and confirmed by us on request in the form of certificates of compliance for the individual products.

Physical characteristics

External compressive strength, load-bearing capacity of the thread as well as pipe dimensions and open areas of the screen pipes fulfil the expectations of operators and owners. Tests of physical characteristics and determining compliance with the applicable rules and standards are carried out at our in-house testing lab.

Design of PVC well materials

Apart from the hydraulic design and dimensioning of screens and casings, the static and dynamic loads during installation and during the various operating states must be estimated correctly.

During installation and filling the annular gap, the well materials are generally subject to the highest tension and external compressive strength, which means that close attention must be paid starting with the design phase concerning the load-bearing capacity and external compressive strength of the pipes and screens. The following statements and diagrams offer professional support in design and well planning.

Filter permeability

A well's potential pumping rate results primarily from the variables:

- Permeability and yield of water-bearing layer
- Permeability of filter gravel
- Permeability of the well screen. These variables must maintain specific ratios to one another which are determined individually for each well.

Permeability of well screens DN 35 to 600, trench width: 0.3 – 3.0 mm

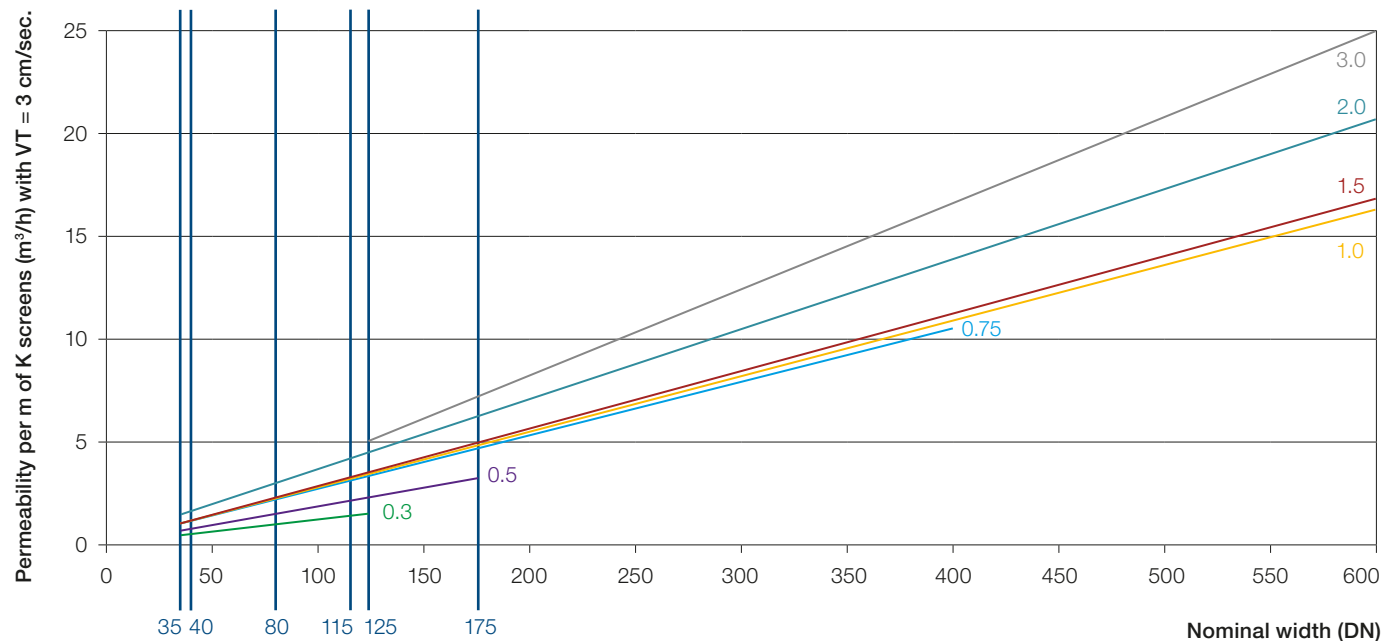

Nomogram for installation depth of casings

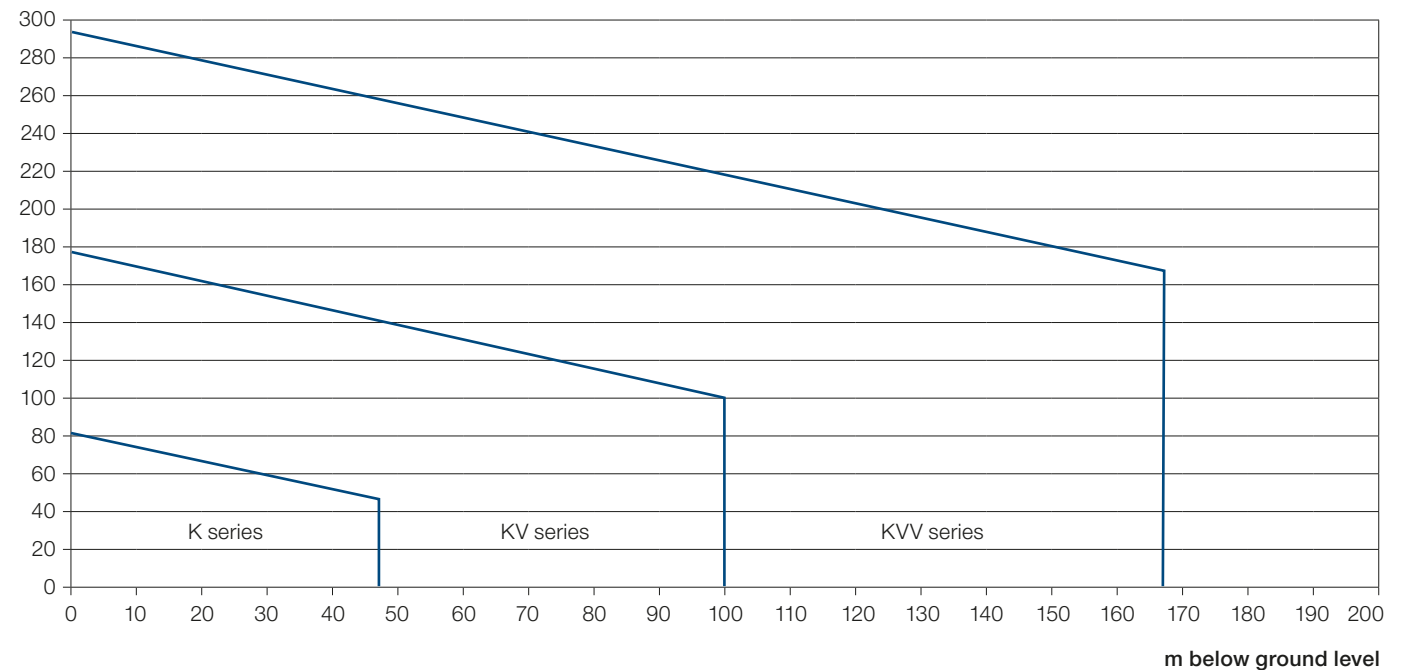

Flushing or water level at time of annular gap backfill

Presupposing that the yield of the aquifer is sufficiently high, the average entrance velocity of water to be pumped is assumed to be 3 cm/s when determining the screen dimensions. This value prevents an increased tendency of incrustations and therefore a reduced period of use, avoiding the risk of potential sand production (if correctly designed according to the above influencing variables).

While previously the open entrance area of the well screen was compared with the open pore area of an actual gravel filling, calculations now focus on the permeabilities of the entire system. The particle size range resulting in the aquifer and particularly the transition to the borehole wall/gravel filling are the focus of calculation nowadays. The wide range of available screen mesh widths enables optimal adjustment of the screen pipes to the grain fraction of the filter gravel filling.

Load-bearing capacity

The tensile stress can first be easily determined based on the pipe weight. However, a potential "suspension" of the gravel filling at the pipe sockets must also be considered during suspended installation and the settlement phase of annular gap backfill. The fact that slotted screen pipes have a lower load-bearing capacity than solid casings can also be significant when installing multiple distributed filter sections in longer pipelines. For this reason, it is not possible to make general statements about permissible installation depths of casings. An estimate of the loads for each specific project is absolutely recommended. For this reason, the tables on the following pages specify the load-bearing capacities of the screen pipes

and casings in detail. These are maximum values under static loads. For the dynamic loads described that occur in water well construction, additional safeguards must be provided.

External compressive strength

The external pressure loads occurring under practical conditions depend on several factors that cannot be calculated precisely in their magnitude. Particularly when installing the gravel filling and annular gap backfill, forces may be generated with a virtually hydrostatic pressure distribution.

The following nomogram provides assistance with selecting which pipe series to install, in which the external pressure load during conventional annular gap backfill with gravel is compared to the external compressive strengths of the casings as a function of the water level of the drilled aquifer.

These result in the theoretical installation limits of the three pipe series K, KV and KVV. The decisive factor for design is the water or flushing level at the time of the annular gap backfill.

As a rule, screen pipes must be selected from the same pipe series as the extension tubes, however due to their permeability they can offset the pressure difference between the annular gap and the well interior and thus be installed up to 30% deeper than the comparable casings. The values listed in the tables of this brochure are derived from the minimum wall thickness of the pipes and an average elasticity modulus of 2,750 N/mm².

Screen pipes and casings made of PVC-U

Product description

PVC-U pipe for drinking water supply standardized according to DIN 4925.



Product characteristics

- Material: PVC-U
- Hygiene certificate pursuant to KTW-BWGL
- Structural length: 1 to 4 m
- Connection type: Pipe thread or trapezoidal thread

Pipe thread

According to DIN 4925 Part 1, with reference to DIN 10226-1, cylindrical female thread and conical male thread, pitch 11 threads per inch, DN 35–DN 100

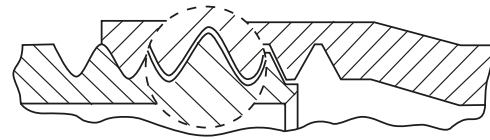

Trapezoidal thread

According to DIN 4925 Part 2 and 3, pitch 6 mm: DN 100–DN 200, pitch 12 mm: DN 250–DN 400, DN 500 and DN 600 according to company standard; special sealing ring available for delivery on request

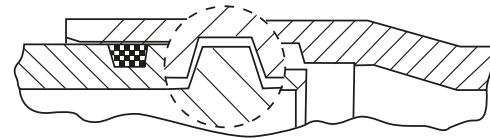

Physical material characteristics***

Characteristics	Unit	Nominal values	Test methods
Elasticity modulus approx.	N/mm ²	2,500–3,000	DIN EN ISO 178
Notch impact strength at 20 °C for PVC-U normal impact strength approx.	kJ/m ²	3–5	DIN EN ISO 179
Density approx.	g/cm ³	1.4	DIN EN ISO 1183
Yield stress approx.	N/mm ²	45–55	DIN EN ISO 527-2
Impact strength		Max. 10% break	In accordance with DIN EN ISO 179
Vicat softening temperature approx.	°C	80	DIN EN ISO 306

Casings (normal walls) – K casing***

DN	External Ø mm	Wall thickness mm	Test pin Ø mm	Connec- tion**	Diameter over spigot socket mm	Load- bearing capacity R kN	Load- bearing capacity T kN	Weight kg/m	Critical external pressure N/mm ²
35	42	3.5	33	R	46	4	-	0.6	4.9
40	48	3.5	39	R	53	5	-	0.7	3.2
50	60	4.0	50	R	66	7	-	1.1	2.4
80	88	4.0	77	R/T	94	8	11	1.6	0.7
100	113	5.0	98	R/T	121	10	17	2.5	0.7
115	125	5.0	110	T	132	-	19	2.8	0.5
125	140	6.5	122	T	149	-	27	4.0	0.8
150	165	7.5	146	T	176	-	40	5.5	0.7
175	195	8.5	170	T	205	-	50	7.4	0.6
200	225	10.0	195	T	241	-	80	10.0	0.7
250	280	12.5	243	T	297	-	100	15.6	0.7
300	330	14.5	290	T	350	-	145	21.2	0.6
350	400	17.5	350	T	425	-	180	31.0	0.6
400	450	19.5	395	T	475	-	260	38.9	0.6
500*	540	20.0	490	T	570	-	240	48.2	0.3
600*	630	18.3	585	T	655	-	174	52.5	0.2

*According to company standard, color blue or gray **R = pipe thread, T = trapezoidal thread

Screen pipes (normal walls) – K screens***

DN	External Ø mm	Wall thickness mm	Test pin Ø mm	Slot width mm	Connec- tion**	Diameter over spigot socket mm	Load-bear- ing capacity Screen pipe kN	Open area with slot width of 1.5 mm %	Weight kg/m
35	42	3.5	33	0.3–2.0	R	46	1.5	9.7	0.6
40	48	3.5	39	0.3–2.0	R	53	2.0	9.7	0.7
50	60	4.0	50	0.3–2.0	R	66	2.5	9.7	1.1
80	88	4.0	77	0.3–2.0	R/T	94	4.0	9.7	1.6
100	113	5.0	98	0.3–2.0	R/T	121	6.5	9.7	2.5
115	125	5.0	110	0.3–2.0	T	132	6.5	9.7	2.8
125	140	6.5	122	0.3–3.0	T	149	10.0	8.8	4.0
150	165	7.5	146	0.5–3.0	T	176	13.0	8.8	5.5
175	195	8.5	170	0.5–3.0	T	205	13.0	8.8	7.4
200	225	10.0	195	0.5–3.0	T	241	26.5	8.8	10.0
250	280	12.5	243	0.5–3.0	T	297	36.5	8.1	15.6
300	330	14.5	290	0.75–3.0	T	350	50.0	8.1	21.2
350	400	17.5	350	0.75–3.0	T	425	65.0	8.1	31.0
400	450	19.5	395	0.75–3.0	T	475	65.0	8.1	38.9
500*	540	20.0	490	0.75–3.0	T	570	70.0	8.0	48.2
600*	630	18.3	585	0.75–3.0	T	655	80.0	8.0	52.5

*According to company standard, color blue or gray **R = pipe thread, T = trapezoidal thread

Casing (thick-walled) – KV casing***

DN	External Ø mm	Wall thickness mm	Test pin Ø mm	Connec- tion**	Diameter over spigot socket mm	Load-bear- ing capacity T kN	Weight kg/m	Critical external pressure N/mm ²
100	113	7.0	94	T	125	28	3.5	1.9
115	125	7.5	105	T	137	30	4.1	1.7
125	140	8.0	118	T	152	35	4.9	1.5
150	165	9.5	140	T	180	55	6.9	1.5
175	195	11.5	163	T	211	80	9.8	1.6
200	225	13.0	188	T	247	120	12.8	1.5
250	280	16.0	236	T	304	150	19.6	1.5
300	330	19.0	281	T	359	220	27.4	1.5
350	400	21.5	342	T	433	230	37.7	1.2
400	450	23.5	387	T	490	330	46.4	1.1

**T = Trapezoidal thread

Screen pipes (thick-walled) – KV screens***

DN	External Ø mm	Wall thickness mm	Test pin Ø mm	Slot width mm	Connec- tion**	Diameter over spigot socket mm	Load-bearing capacity screen pipe kN	Open area with slot width of 1.5 mm %	Weight kg/m
100	113	7.0	94	0.3–2.0	T	125	10	9.7	3.5
115	125	7.5	105	0.3–2.0	T	137	10	9.7	4.1
125	140	8.0	118	0.5–3.0	T	152	12	8.8	4.9
150	165	9.5	140	0.5–3.0	T	180	15	8.8	6.9
175	195	11.5	163	0.75–2.0	T	211	20	8.8	9.8
200	225	13.0	188	1.0–2.0	T	247	30	8.8	12.8
250	280	16.0	236	0.75–3.0	T	304	40	8.1	19.6
300	330	19.0	281	0.75–3.0	T	359	60	8.1	27.4
350	400	21.5	342	1.0–3.0	T	433	70	8.1	37.7
400	450	23.5	387	1.0–3.0	T	490	75	8.1	46.4

**T = Trapezoidal thread

Casing (extra thick-walled) – KVV casing***

DN	External Ø mm	Wall thickness mm	Test pin Ø mm	Connec- tion**	Diameter over spigot socket mm	Load-bear- ing capacity T kN	Weight kg/m	Critical external pressure N/mm ²
80	90	6.7	75	T	100	30	2.6	3.4
100	113	8.2	92	T	127	35	4.0	3.1
125	140	10.4	112	T	157	50	6.3	3.4
150	165	12.0	132	T	185	70	8.5	3.2
175	195	12.8	160	T	214	85	10.8	2.3
200	225	14.5	185	T	250	130	14.2	2.1
250	280	18.5	230	T	309	180	22.4	2.3
300	330	21.5	272	T	364	260	30.7	2.2
350	400	24.0	345	T	435	270	41.7	1.7

**T = Trapezoidal thread

Screens (extra thick-walled) – KVV screens***

DN	External Ø mm	Wall thickness mm	Test pin Ø mm	Slot width mm	Connec- tion**	Diameter over spigot socket mm	Load-bearing capacity screen pipe kN	Open area with slot width of 1.5 mm %	Weight kg/m
80	90	6.7	75	0.3–2.0	T	100	10	9.7	4.0
100	113	8.2	92	0.3–2.0	T	125	11	9.7	4.0
125	140	10.4	112	0.3–2.0	T	137	12	8.8	6.3
150	165	12.0	132	0.5–3.0	T	152	25	8.8	8.5
175	195	12.8	160	0.5–3.0	T	180	30	8.8	10.8
200	225	14.5	185	0.75–2.0	T	211	40	8.8	14.2
250	280	18.5	230	1.0–2.0	T	247	60	8.1	22.4
300	330	21.5	272	0.75–3.0	T	304	80	8.1	30.7
350	400	24.0	345	0.75–3.0	T	359	95	8.1	41.7

**T = Trapezoidal thread

***The specified values are valid at 23 °C (+/- 2 °C) and 50% humidity

Gravel pre-packed screens

Product description

Gravel pre-packed screens offer the advantage of uniform gravel filling even in shafts where gravel filling is laborious and thus expensive or unsafe to implement.

Product characteristics

- Material: PVC-U with gravel sheath made of a gravel-resin-hardener mixture
- Standards: DIN 4925 Part 1 to 3
- Lengths: DN 35 to DN 80 = 1.0 m
DN 100 to DN 400 = 2.0 m
- Slot widths/graining

sw - mm	Graining - mm
0.75	0.71–1.25
1.50	1.60–2.50
2.00	2.00–3.15
3.00	3.15–5.60

Benefits

- Permeability is the same as that of K pipes
- Graining size can be adjusted to soil requirements

Product characteristics

DN	Wall thickness mm	External Ø over gravel mm	Gravel coating thickness mm	Thread R/T*	Weight kg/m
35	3.5	66	11	R	3.4
40	3.5	72	11	R	3.5
50	4.0	91	15	R	5.0
80	4.0	122	15	R/T	8.0
100	5.0/7.0	146	15	R/T	11.5/12.5
115	5.0/7.5	160	15	T	12.5/13.8
125	6.5/8.0	173	15	T	13.5/14.4
150	7.5/9.5	199	15	T	17.2/18.6
175	8.5/11.5	227	15	T	20.0/22.8
200	10.0/13.0	259	15	T	24.5/27.3
250	12.5/16.0	312	15	T	33.5/37.5
300	14.5/19.0	364	15	T	44.0/50.2
350	17.5/21.5	439	18	T	63.0/69.7
400	19.5/23.5	488	18	T	74.0/81.5

*R = pipe thread, T = trapezoidal thread



TNA casings and screen pipes

Product description

The primary applications of this screen type are pipework for insertion in existing wells and narrow borehole diameters.

Product characteristics

- Material: PVC-U
- Structural length: 1 to 4 m
- Connection type: TNA (non-protruding trapezoidal thread)

Benefits

Thread cut into the wall, thread diameter and slope according to company standard

Physical material characteristics*

Characteristics			Test methods
Elasticity modulus approx.	N/mm ²	2,500–3,000	DIN EN ISO 178
Notch impact strength at 20 °C for PVC-U normal impact strength approx.	kJ/m ²	3-5	DIN EN ISO 179
Density approx.	g/cm ³	1.4	DIN EN ISO 1183
Yield stress approx.	N/mm ²	45–55	DIN EN ISO 527-2
Impact strength		Max. 10% break	In accordance with DIN EN ISO 179
Vicat softening temperature approx.	°C	80	DIN EN ISO 306



Casings (normal walls)*

DN	Wall thickness mm	Test pin Ø mm	External Ø mm	Load-bearing capacity TNA kN	Weight kg/m	Critical external pressure N/mm ²
100	5.0	98	113	10	2.5	0.7
115	5.0	110	125	12	2.8	0.5
125	6.5	122	140	15	4.0	0.8
150	7.5	146	165	20	5.5	0.7
175	8.5	170	195	25	7.4	0.6
200	10.0	195	225	40	10.0	0.7
250	12.5	243	280	50	15.6	0.7
300	14.5	290	330	80	21.2	0.6
350	17.5	350	400	90	31.0	0.6
400	19.5	395	450	100	38.9	0.6

Screen pipe (normal walls)*

DN	Wall thickness mm	Test pin Ø mm	Slot width mm	External Ø mm	Load-bearing capacity Screen pipe kN	Open area with slot width of 1.5 mm %	Weight kg/m
100	5.0	98	0.3–2.0	113	6.5	9.7	2.5
115	5.0	110	0.3–2.0	125	6.5	9.7	2.8
125	6.5	122	0.3–3.0	140	10.0	8.8	4.0
150	7.5	146	0.5–3.0	165	13.0	8.8	5.5
175	8.5	170	0.5–3.0	195	13.0	8.8	7.4
200	10.0	195	0.5–3.0	225	26.5	8.8	10.0
250	12.5	243	0.5–3.0	280	36.5	8.1	15.6
300	14.5	290	0.75–3.0	330	50.0	8.1	21.2
350	17.5	350	0.75–3.0	400	65.0	8.1	31.0
400	19.5	395	0.75–3.0	450	65.0	8.1	38.9

Casings (thick-walled)*

DN	Wall thickness mm	Test pin Ø mm	External Ø mm	Load-bearing capacity TNA kN	Weight kg/m	Critical external pressure N/mm ²
100	7.0	94	113	12	3.5	1.9
115	7.5	105	125	15	4.1	1.7
125	8.0	118	140	18	4.9	1.5
150	9.5	140	165	30	6.9	1.5
175	11.5	163	195	35	9.8	1.6
200	13.0	188	225	55	12.8	1.5
250	16.0	236	280	75	19.6	1.5
300	19.0	281	330	110	27.4	1.5
350	21.5	342	400	110	37.7	1.2
400	23.5	387	450	130	46.4	1.1

Screen pipes (thick-walled)*

DN	Wall thickness mm	Test pin Ø mm	Slot width mm	External Ø mm	Load-bearing capacity Screen pipe kN	Open area with slot width of 1.5 mm %	Weight kg/m
100	7.0	94	0.3–2.0	113	10	9.7	0.6
115	7.5	105	0.3–2.0	125	10	9.7	0.7
125	8.0	118	0.5–3.0	140	12	9.7	1.1
150	9.5	140	0.5–3.0	165	15	9.7	1.6
175	11.5	163	0.75–2.0	195	20	9.7	2.5
200	13.0	188	1.0–2.0	225	30	9.7	2.8
250	16.0	236	0.75–3.0	280	40	8.8	4.0
300	19.0	281	0.75–3.0	330	60	8.8	5.5
350	21.5	342	1.0–3.0	400	70	8.8	7.4
400	23.5	387	1.0–3.0	450	75	8.8	10.0

Extra thick-walled models according to the company standard are available on request.

*The specified values are valid at 23 °C (+/- 2 °C) and 50% humidity

GWE NORESTA®

Product description

Pressure-tight well pipe with tension-resistant push-fit sleeve connection.

Product characteristics

- Material: PVC-U
- Structural length: 1 to 6 m
- Connection type: ZSM

Benefits

- Precision-made sealing surfaces guarantee a tight seal despite internal and external pressure
- Thick-walled pipe system suitable for installation up to a depth of approx. 200 m
- Quick, tool-free installation using a tension-resistant push-fit sleeve system



Load-bearing capacities and compressive strengths**

DN	Load-bearing capacity casing/screen pipe kN	External compressive strength N/mm ²	Internal compressive strength N/mm ²
100	16/10	1.9	1.3
150	30/15	1.5	1.2
175	45/20	1.6	1.3
200	60/30	1.5	1.2
250	80/40	1.5	1.2
300	100/60	1.5	1.2
350	100/70	1.2	1.1
400	110/80	1.1	1.0

Dimensions and weights**

DN	External Ø mm	Wall thickness mm	Test pin Ø mm	External Ø over spigot socket mm	Weight spigot socket kg	Weight kg/linear meter
100	113	7.0	94	134	0.7	3.5
150	165	9.5	140	194	1.2	6.9
175	195	11.5	163	225	3.4	9.8
200	225	13.0	188	262	4.2	12.8
250	280	16.0	236	320	7.6	19.6
300	330	19.0	281	370	8.8	27.4
350	400	21.5	342	450	13.5	37.7
400	450	23.5	387	500	15.0	46.4

Slot widths: 0.3* - 0.5 - 0.75 - 1.0 - 2.0 - 3.0 mm

*= * only up to DN 100

Physical characteristics**

Characteristics	Units	Nominal values	Test methods
Elasticity modulus	N/mm ²	2,500–3,000	DIN EN ISO 178
Notch impact strength at 20 °C	kJ/m ²	3-5	DIN EN ISO 179
Density	kg/dm ³	1.4	DIN EN ISO 1183
Yield stress	N/mm ²	45–55	DIN EN ISO 527-2
Impact strength		Max. 10% break	In accordance with DIN EN ISO 179
Vicat softening temperature	°C	80	DIN EN ISO 306

For installation we recommend use of the GWE lubricant with KTW (drinking water plastic) approval.

**The specified values are valid at 23 °C (+/- 2 °C) and 50% humidity



GWE NORESTA® 2.0

Product description

The pressure-tight GWE well casing with tension-resistant push-fit sleeve connection and spigot socket glued on one side in dimensions from DN 300–DN 400 offers additional benefits for operators in solutions for standard and special requirements in horizontal and vertical media transport.



Product characteristics

- Material: PVC-U
- Structural length: 1 to 6 m
- Connection type: ZSM

Benefits

- Precision-made sealing surfaces for a tight seal despite internal and external pressure
- Strong-walled PVC solid pipe system for installation up to a depth of approx. 150 m
- Absorption of high tensile forces up to 150 kN (15 t)
- Specially designed for PVC/steel combination expansions, including with gravel cages
- Double O-ring seal – means no peaks during geophysical exploration with FEL (BFEL)
- Interception possible directly below the spigot socket
- Tool-free installation with only a shear rod using a tension-resistant push-fit sleeve system
- Corrosion-free and extremely chemically resistant

Load-bearing capacities and compressive strengths*

DN	Load-bearing capacity casing kN	External compressive strength N/mm ²	Internal compressive strength N/mm ²
300	150	1.5	1.2
350	150	1.2	1.1
400	150	1.1	1.0

Dimensions and weights*

DN	External Ø mm	Wall thickness mm	Test pin Ø mm	External Ø over spigot socket mm	Weight spigot socket kg	Weight kg/linear meter
300	330	19.0	281	370	8.8	27.4
350	400	21.5	342	450	13.5	37.7
400	450	23.5	387	500	15.0	46.6

Physical characteristics*

Characteristics	Units	Nominal values	Test methods
Elasticity modulus	N/mm ²	2,500–3,000	DIN EN ISO 178
Notch impact strength at 20 °C	kJ/m ²	3–5	DIN EN ISO 179
Density	kg/dm ³	1.4	DIN EN ISO 1183
Yield stress	N/mm ²	45–55	DIN EN ISO 527-2
Impact strength		Max. 10% break	In accordance with DIN EN ISO 179
Vicat softening temperature	°C	80	DIN EN ISO 306

Installation instructions:

- To install the connection, a special lifting cap with integrated holding straps is required. More detailed instructions can be found in the NORESTA 2.0 installation guide.
- For installation we recommend use of the GWE lubricant with KTW (drinking water plastic) approval.

*The specified values are valid at 23 °C (+/- 2 °C) and 50% humidity



GWE NORIP®

Product description

The safe solution for groundwater measurement points.

Product characteristics

- Material: PVC-U
- Structural length: 1 to 6 m
- Connection type: Double spigot socket with trapezoidal thread



Benefits

- Permanently leak-tight pipe connections thanks to specially developed double spigot socket
- Robust design thanks to high notch impact strength
- Easy screw connection of trapezoidal thread for secure and fast installation

Technical data*

SBF NORIP® double spigot socket

DN	External Ø mm	Length mm
50	75	80
65	92	76
80	106	99
115	143	106
125	162	142

Standard sealing made of elastomer material

SBF NORIP® pipes

DN	External Ø mm	Wall thickness mm	Weight kg/m	External compressive strength N/mm²	Load-bearing capacity casing/ screen pipe kN
50	60	6.0	1.5	7.3	12.0/4.0
65	75	7.5	2.4	7.3	25.0/8.0
80	90	5.0	2.0	1.1	15.3/5.5
115	125	7.5	4.1	1.4	35.0/11.0
125	140	8.0	4.9	1.2	45.0/16.0

Slot widths: 0.3 (only up to DN 115) – 0.5 – 0.75 – 1.0 – 1.5 – 2.0 – 3.0 mm

Physical characteristics*

Characteristics	Unit	Requirement	Test methods
Elasticity modulus approx.	N/mm²	2,000–2,500	DIN EN ISO 178
Notch impact strength at 23 °C approx.	kJ/m²	10–20	DIN EN ISO 179
Density approx.	g/cm³	1.4	DIN EN ISO 1183
Yield stress approx.	N/mm²	45–55	DIN EN ISO 527-2
Impact strength approx.		Max. 10% break	In accordance with DIN EN ISO 179
Vicat softening temperature approx.	°C	80	DIN EN ISO 306

*The specified values are valid at 23 °C (+/- 2 °C) and 50% humidity



PVC wire-wrapped screen

Product description

High filter capacity combined with the benefits of PVC material. Even at larger diameters, e.g. DN 300, minimal gap widths can be achieved, e.g. 0.2 m.



Product characteristics

- Material: PVC-U
- Structural length: 1 to 3 m
- Connection types:
 - Pipe thread (only DN 50)
 - Trapezoidal thread (DN 80–DN 300)

Benefits

- Open area of up to 20%
- Minimal slot widths even with large nominal widths
- High dimensional stability thanks to steel-reinforced PVC wire wrap profile
- Thread connection according to DIN 4925

Physical material characteristics**

Characteristics	Unit	Requirement	Test methods
Elasticity modulus approx.	N/mm ²	2,500–3,000	DIN EN ISO 178
Notch impact strength at 20 °C for PVC-U normal impact strength approx.	kJ/m ²	3–5	DIN EN ISO 179
Density approx.	g/cm ³	1.4	DIN EN ISO 1183
Yield stress approx.	N/mm ²	45–55	DIN EN ISO 527-2
Impact strength		Max. 10% break	In accordance with DIN EN ISO 179
Vicat softening temperature approx.	°C	80	DIN EN ISO 306

Technical data**

Filter capacity at 3 cm/s filter entry speed

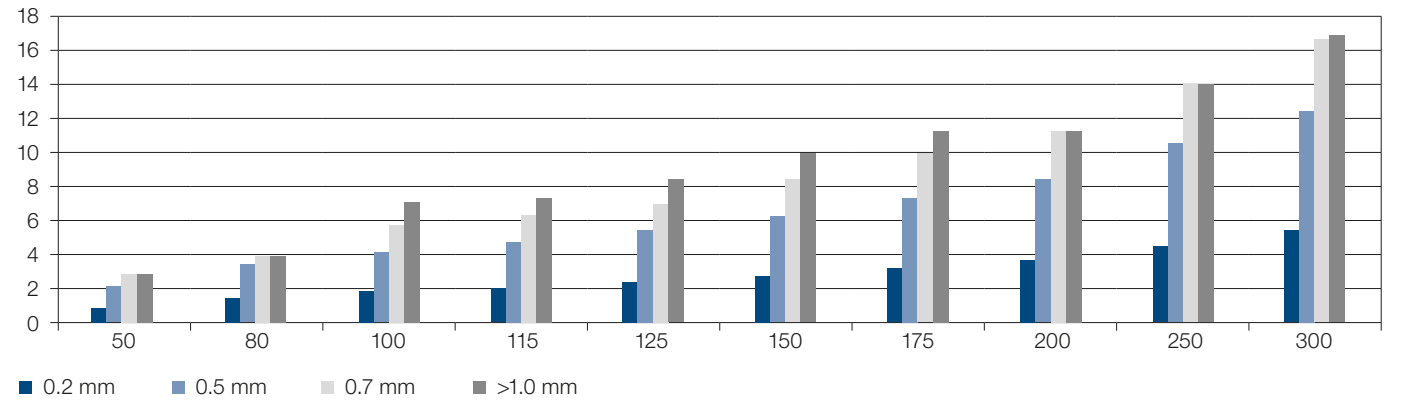

Design**

DN	External Ø mm	Screen type	Wall thickness mm	Connection	Max. external Ø mm	Diameter over wire wrap mm	Capacity with SW 1.0 mm in m³/h per m of screen*	Weight kg/m
50	60	K/KV	4.0/6.0	R	71	68	2.5	1.8/2.1
80	88	K/KV	4.0/7.0	T	101	99	4	2.9/3.9
100	113	K/KV	5.0/7.0	T	129	125	7	3.7/4.7
115	125	K/KV	5.0/7.5	T	140	137	7	4.2/5.5
125	140	K/KV	6.5/8.0	T	157	155	8.5	5.4/6.3
150	165	K/KV	7.5/9.5	T	181	179	9.8	6.9/8.3
175	195	K/KV	8.5/11.5	T	215	210	11.5	8.9/11.3
200	225	K/KV	10.0/13.0	T	245	240	11.5	11.3/14.1
250	280	K/KV	12.5/16.0	T	300	294	14	16.9/21.0
300	330	K/KV	14.5/19.0	T	358	345	17	22.5/28.7

K = normal-walled

KV = thick-walled

*Applies for an entry flow speed of 3 cm/s

**The specified values are valid at 23 °C (+/- 2 °C) and 50% humidity

VALUE PVC screen pipes and casings

Product description

Specially designed for the particular demands of water well construction. For installation depths up to 150 m.

Product characteristics

- Material: PVC-U
- Connection type: Glued socket
- External compressive strengths up to 10 bar



Technical data***

Filter capacity at 3 cm/s filter entry speed

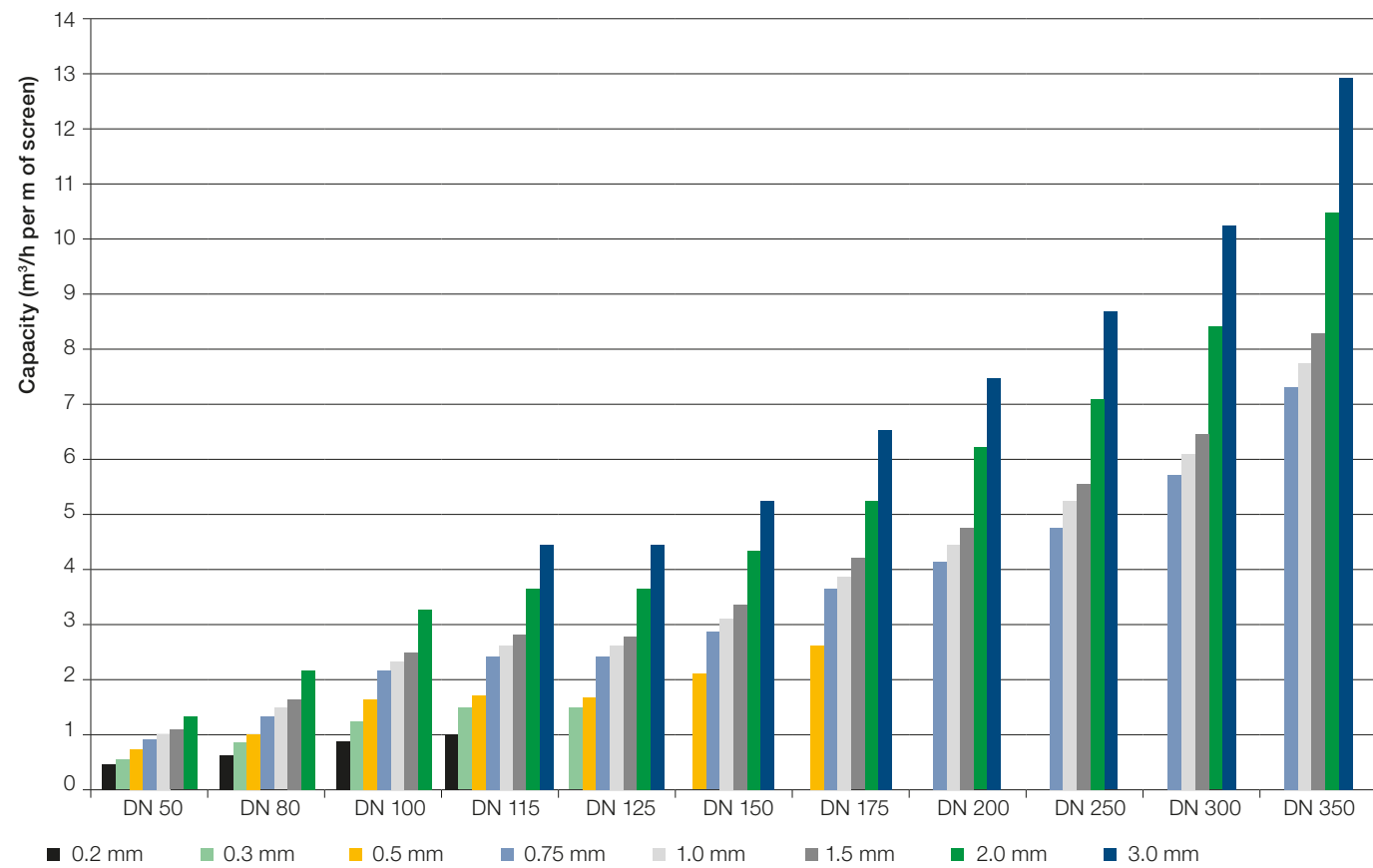

Slot widths: 0.2 – 0.3 – 0.5 – 0.75 – 1.0 – 1.5 – 2.0 – 3.0 mm

Designs of casings***

Nominal width and external diameter mm		Nominal wall thickness* mm		
DN	Da	Series 1**	Series 2**	Series 3**
50	60			4.0
80	90	3.5		5.0
100	113	3.9	5.0	5.7
115	125	4.3	5.0	6.3
125	140	4.8	6.5	7.1
150	165	5.7	7.5	8.3
175	195	6.7	8.5	9.9
200	225	7.8	10.0	11.4
250	280	9.7	12.5	14.2
300	330	11.4	14.5	16.7
350	400	13.8	17.5	20.3

Additional models and connection types available on request.

***The specified values are valid at 23 °C (+/- 2 °C) and 50% humidity

Key

*Wall thickness tolerances:
 DN 50 to DN 150: +/- 0.5 mm
 DN 175 to DN 250: +/- 0.9 mm
 DN 300 to DN 350: +/- 1.2 mm

**Depending on the installation procedure and the geology, the following installation depths can be achieved:

- Series 1 up to 50 m
- Series 2 up to 100 m
- Series 3 up to 150 m

Lowering screens and solid pipes

Product description

The lowering screens and solid pipes are made of PVC-U plastic and thus absolutely corrosion-free. The favorable ratio of material consumption to duration of use resulting from the extraordinarily long service life explains the economical and ecological benefits of products made from PVC-U.



Product characteristics

- Material: PVC-U
- Connection type: Spigot sleeve
- Slot type: Longitudinal slot

Technical data*

DN	Wall thickness mm	External Ø mm	Internal Ø mm	External Ø over spigot socket mm	Weight kg/m	Total length m
200	6.6	225	211.8	245	8.0	6.0
300	9.2	315	296.6	336	15.3	6.0
400	9.8	400	381.6	420	20.8	6.0

Slot widths: 0.75 – 1.0 – 1.5 – 2.0 mm
 Total length KLM adapters 1.0 m
 Color: not specified

Physical characteristics*

Characteristics		Nominal values	Test methods
Elasticity modulus approx.	N/mm ²	> 2,500	DIN EN ISO 178
Density approx.	g/cm ³	1.66	DIN 53479
Yield stress approx.	N/mm ²	< 45	DIN EN ISO 527-2
Vicat softening temperature approx.	°C	80	DIN EN ISO 306

Filter capacity and open area*

DN \ sw	Filter capacity m ³ /h/m				Open area %			
	0.75 mm	1.0 mm	1.5 mm	2.0 mm	0.75 mm	1.0 mm	1.5 mm	2.0 mm
200	3.5	4.6	6.5	8.1	4.9	6.4	9.0	11.3
300	3.9	5.0	7.0	8.9	3.9	5.0	7.0	8.9
400	6.4	8.3	11.8	14.9	5.0	6.5	9.2	11.6

*The specified values are valid at 23 °C (+/- 2 °C) and 50% humidity

Special pipes – PVC casings – special dimensions

Product description

As a supplement to our normal and thick-walled product series, we offer a range of special pipes.



Product characteristics

- Material: PVC-U
- Hygiene certificate pursuant to KTW-BWGL
- Structural length: 1, 2, 3, 4, 5, 6 m

Technical data**

DN*	External diameter mm	Wall thickness mm	Test pin Ø mm	Connec- tion**	Diameter over spigot socket mm	Load-bear- ing capacity T KN	Weight kg/m	Critical external pressure N/mm ²
50	60	4.5	49	TNA	-	3.8	1.2	3.5
65	75	5.5	61	TNA	-	7.5	1.8	3.2
80	90	5.5	76	TNA	-	8.9	2.2	1.8
115	125	6.0	108	TNA	-	12.5	3.3	0.8
125	140	5.0	125	TIA	146	3.7	3.2	0.3
150	165	5.0	150	TIA	171	3.8	3.7	0.2
200	225	7.0	205	TIA	235	5.3	7.1	0.2

*Larger dimensions available by request

**The specified values are valid at 23 °C (+/- 2 °C) and 50% humidity

Special pipes – HLS High-performance slotted screens

Product description

PVC screens with a large open area for applications in which a high capacity is required. In combination with non-protruding TNA connections, these screens are particularly suited as pipework for insertion in existing wells to prevent corrosion with the existing construction.



Areas of application

- Drinking water wells
- New well construction and rehabilitation
- Flat wells with temporary large water needs
- Service, irrigation and fire extinguishing wells
- Discharge wells

Product characteristics

- Material: PVC-U with KTW-BWGL (drinking water approval)
- Structural length: 1 to 4 m
- Connection type: Trapezoidal thread according to DIN 4925 and TNA according to company standard
- ca. 30% reduced external compressive strength, accordingly also 30% less installation depth

Physical material characteristics*

Characteristics	Unit	
Elasticity modulus approx.	N/mm ²	2,500–3,000
Density approx.	kJ/m ²	1.4
Impact strength	-	Max. 10% break
Notch impact strength	N/mm ²	3–5
Yield stress approx.	N/mm ²	45–55

Models*

DN	External Ø mm	Wall thickness mm	Open area % for slot widths mm					Load-bearing capacity kN
			0.75	1.0	1.5	2.0	3.0	
100	113	5.0	13.6	12.8	17.3	21.2	24.2	4.8
		7.0						5.8
115	125	5.0	15.2	14.3	19.3	23.6	27.0	2.7
		7.5						3.1
125	140	6.5	13.5	12.7	17.2	21.1	24.1	8.1
		8.0						9.4
150	165	7.5	14.5	13.7	18.5	22.6	25.8	8.0
		9.5						9.2
175	195	8.5	14.4	13.6	18.4	22.5	25.7	9.6
		11.5						11.3
200	225	10.0	15.1	14.3	19.3	23.6	27.0	9.1
		13.0						10.0
250	280	12.5	11.8	11.1	15.0	18.3	21.0	49.6
		16.0						59.6
300	330	14.5	12.3	11.6	15.6	19.1	21.8	63.0
		19.0						76.9
350	400	17.5	14.7	13.9	18.8	23.0	26.3	22.7
		21.5						23.2
400	450	19.5	12.8	12.1	16.3	19.9	22.8	82.9
		23.5						90.6

Capacity HLS screens compared to DIN 4925*

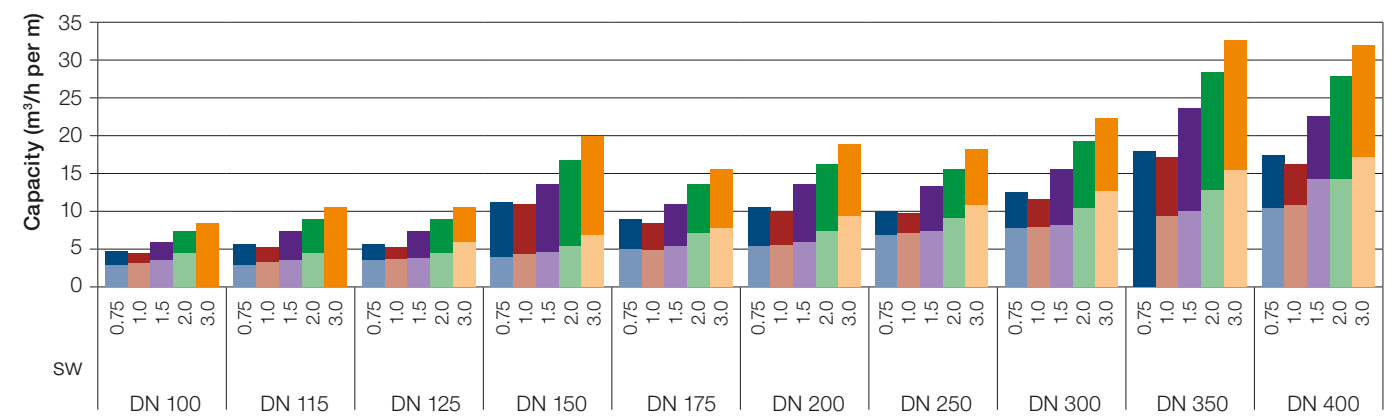

*The specified values are valid at 23 °C (+/- 2 °C) and 50% humidity

Special pipes – PVC glass bead pre-packed screens

Product description

PVC-U glass bead pre-packed screens are ideally suited based on cost-benefit considerations for temporarily operated groundwater measurement points, either for narrow drilling diameters or with double gravel filling for fine sandy soils. Even for deep drilling it offers benefits by ensuring a uniform coating thickness of the bulk material.

Product characteristics

- Material: PVC-U according to DIN 4925 with glass bead coating
- Trapezoidal thread (Tr) according to DIN 4925
- Glass bead filling variable depending on soil class
- Diameter range DN 50 to 125 (other dimensions after consultation)
- Depending on the installation depth, thick-walled screens may also be used.
- Slot widths filling variable depending on soil class sw 1.0 to 3.0 mm
- Pore volume approx. 36 to 39%

Benefits

- High adhesive strength of glass bead coating on PVC-U screens
- Double gravel filling possible, which reduces the entry of fine sand
- Screens can also be directly installed in the borehole without external gravel filling. In this process, a natural gravel filter layer should be build up due to intensive well development.
- Thanks to the circular bead shape, low adhesion of incrustations to the exterior sheath of the beads.
- Due to uniform pore channel, high mobility of soil particles that have entered. As a result, less formation of particle bridges and prevention of internal siltation.

Technical data glass bead pre-packed screen**

DN	Wall thickness mm	Graining (optionally) mm	Connection	Diameter over glass bead coating mm	Load-bearing capacity screen pipe kN	Filter capacity m ³ /h/m with slot width of 1.0 mm	Weight kg/m
50	4.0	1.0–1.3 2.0–2.4	RIA*	91	2.5	1.3	5.0
80	4.0	1.25–1.65 3.8–4.4	T*	122	4.0	2.1	8.0
100	5.0	1.25–1.65 3.8–4.4	T*	146	6.5	2.7	11.5
125	6.5	1.25–1.65 3.8–4.4	T*	173	10.0	3.3	13.5

*RIA = pipe thread / T = trapezoidal thread
Other dimensions available by request

**The specified values are valid at 23 °C (+/- 2 °C) and 50% humidity



Special pipes – PVC double sheath screen

Product description

The PVC-U double sheath screen is used wherever a double filter gravel filling has to be constructed in fine sandy soils so that effective particle bridges can build up in the filter body to prevent siltation during well operation. Glass beads have proven particularly effective here, since incrustations cannot adhere to the circular beads as easily as on naturally developed gravel particles. This achieves a long service life for the well even after multiple regeneration intervals.

Product characteristics

- Material: PVC-U according to DIN 4925 with glass beads
- Trapezoidal thread (Tr)
- Glass bead filling 1.5 to 8.0 mm variable depending on soil class
- Screen sizes: DN 175/300; DN 200/350; DN 250/400; DN 350/500
- Depending on the installation depth, the internal screen can also be constructed in a thick-walled design.
- Slot widths filling variable depending on soil class sw 1.0 to 3.0 mm

Benefits

- High resistance to acids, bases and high chloride content
- Double gravel filling possible, which reduces the entry of fine sand
- Frequent regeneration intervals possible due to smooth surface of glass bead filling.
- Buildup of a siltation layer is prevented by a large internal glass bead filling adapted to the soil stratum. The external slot



width is selected so that a smaller filling bead diameter can be used there.

- Screens can also be directly installed in the borehole without external gravel filling. In this process, a natural gravel filter layer should be build up due to intensive well development (e.g. jetting).



Standard lengths 1 to 2 m

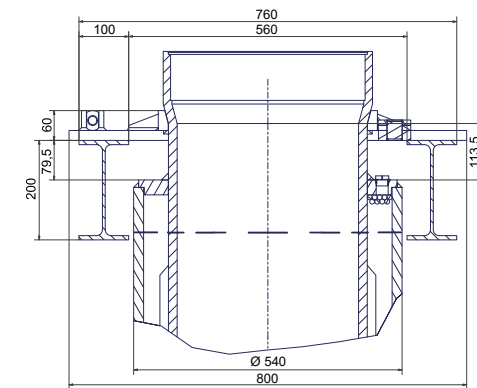

Design of retaining clamp with girder supports

Technical data for screens with*

Slot widths: Internal screen sw 1.5 mm / External screen sw 1.0 mm;
Glass bead diameter: 3.4 to 4.0 mm

Screen size mm	External screen - External Ø - Wall thickness Internal screen - External Ø - Wall thickness mm	Weight kg/m	Open area %	Filter capacity m³/h/m	Max. external compressive strength N/mm²	Max. installation depth m	Max. tensile strength kN
175/300	330	88.6	8.1	4.8	0.48	91	21
	14.5						
	195						
	8.5						
200/350	400	138.3	8.1	5.5	0.51	95	43
	17.5						
	225						
	10.0						
250/400	450	161.2	8.1	7.0	0.52	95	59
	19.5						
	280						
	12.5						
350/500	540	187.5	8.1	9.5	0.51	90	105
	20						
	400						
	17.5						

*The specified values are valid at 23 °C (+/- 2 °C) and 50% humidity

Special pipes – PVC-U well blocking pipes

Product description

Blocking pipes are used in water well construction in order to first ensure stability in the borehole area near the surface. Optimally, the locking pipes are installed down to the first aquiclude and cemented in backwards to prevent surface water from entering the borehole and permanently blocking off the uppermost aquifer.

Pressure-tightness up to 2.5 bar is achieved by the push-fit sleeve connection with integrated sealing ring. In order to achieve a friction lock between the pipes for vertical installation in the borehole, the connections are secured by self-tapping screws.

Product characteristics

- Material: absolutely corrosion-free PVC-U; color blue
- Installation depth up to approx. 30 m
- Connection type: Spigot sleeve with permanently inserted CI sealing
- Minimum pressure tightness of connection 2.5 bar
- Friction lock of connection with 6 pcs. self-tapping screws M8
- Installation of base flange and sanding of base flange area for better sealing by injection slurry possible by consultation

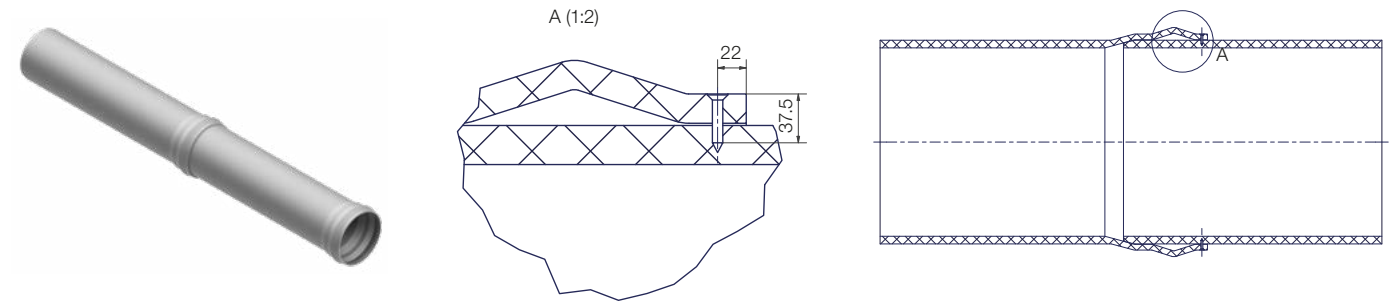
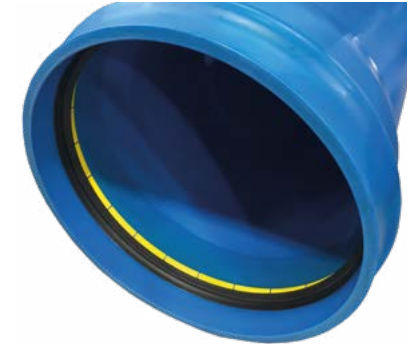

Technical data*

DN/OD	Wall thickness mm	Internal Ø mm	Ø over spigot socket mm	Weight kg/m	Total length m
630	18.4	593.2	720	50.0	3.0/6.0
800	23.4	753.2	900	80.5	3.0/6.0

*The specified values are valid at 23 °C (+/- 2 °C) and 50% humidity

Special pipes – Notched and grooved fabric filter

Product description

The filter is outfitted with notches and grooves that are drilled in at fixed intervals. The filter is covered with a Dutch weave filter fabric and sheathed with a protective stocking.



Technical data

- Structural length:
 - DN 50–DN 80 = 1.0 – 1.5 – 2.0 m
 - DN 100–DN 200 = 1.0 – 2.0 m
- PP Dutch weave fabric:
 - No. 10 = 290 micron filter fineness
 - No. 12 = 210 micron filter fineness
 - No. 15 = 190 micron filter fineness
 - No. 20 = 140 micron filter fineness

■ Dimensions/weight

DN	External Ø mm	Wall thickness mm	Test pin Ø mm	Weight kg/linear meter	Thread type*
50	60	4.0	50	0.9	R2"
80	88	4.0	77	1.1	R3"
100	113	5.0	98	2.0	T4"
115	125	5.0	110	2.2	T 4 ½"
125	140	6.5	122	3.1	T5"
150	165	7.5	146	4.1	T6"
200	225	10.0	195	7.5	T8"

*Thread according to DIN 4925 and company standard

■ Flow rate

DN	Flow rate m³/h/m at 30 mm/s entry flow speed			
	With 140 microns	With 190 microns	With 210 microns	With 290 microns
50	3.0	3.9	4.4	5.3
80	4.6	6.0	6.8	8.1
100	5.9	7.7	8.7	10.5
115	6.6	8.6	9.7	11.7
125	7.3	9.5	10.8	12.9
150	8.6	11.2	12.7	15.3
200	11.8	15.3	17.4	20.9

Special pipes – Steel ram filter

Product description

For small-scale pumping and secondary water supply, driven wells can be constructed quickly and cost-effectively. The system comprises a ram filter, suction pipe and a piston pump or an electric, self-priming centrifugal pump, e.g. a GWE garden pump, Type JP 3, 5 or 6 made of chromium-nickel steel. The system is well-established for supplying water to troughs and livestock watering tanks in pastures, for garden plots or for small-scale gardening. This equipment is rarely used for the purpose of household water supply, however it is increasingly used for watering gardens on private property.



Product characteristics

- Material: Galvanized steel pipe with boreholes and brass mesh
- Ram tip: Steel ram tip, solid
- Thread: Male pipe thread in accordance with DIN EN 10226-1
- Structural length: 1.0 m

Technical data

DN/OD	External Ø mm	Wall thickness mm	Max. external Ø over tip mm	Ram filter length mm	Length of ram tip m	Weight kg/m
1 ¼"	42.4	3.25	57	1,150	145	5.0
1 ½"	48.3	3.50	68	1,150	160	6.5
2"	60.3	3.65	78	1,150	180	9.0

Accessories

Ram filter extensions with brass mesh and protective sheath in lengths of approx. 100 cm with male pipe threads on both sides in accordance with DIN EN 10226-1

PVC well heads

Product description

The PVC well head is placed onto the well pipe and glued on. This offers a simple, economical and secure well connection. The easy-to-install capping beam of the well head also enables rapid access to the well.

Product characteristics

- Material: Capping beam made of PU/bottom part made of PU/PVC-U
- O-ring sealing between capping beam and flange ensures rainwater tightness
- Attachment possible using conventional PVC-U adhesives (e.g. Tangit)
- Enhanced leak tightness up to 1 bar possible by using a flat seal



Benefits

- Cable glands with metric connection thread
- Stainless steel screws with optimized diameter
- Threaded coupler made of stainless steel guarantees a secure, dimensionally stable screw connection even after multiple installation and dismantling of pump riser pipe
- Greater ease of installation with integrated hexagonal mount on the underside of the flange
- PVC pipe with adhesive socket for secure well closure
- Dimensional specifications on the well head cap

Technical data

DN*	Thread	External Ø mm	Height approx. mm	Screws	Load-bearing capacity kN
80	1"-1 1/4"	165	190	4 x M8	7.5
100	1 1/4"-2"	185	200	4 x M8	7.5
115	1 1/4"-2"	185	210	4 x M8	7.5
125	1 1/4"-2"	225	210	6 x M 12	10.0
150	1 1/4"-2"	250	220	6 x M 12	10.0
175	1 1/4"-2"	280	280	6 x M 12	10.0
200	1 1/4"-2"	320	300	6 x M 16	15.0
250	2"-4"	375	340	6 x M 16	15.0
300	2"-4"	425	400	6 x M 16	15.0

*Larger dimensions available by request

Fire extinguishing wells pursuant to DIN 14220

Product description

A fire extinguishing well is an artificial point for the extraction of extinguishing water from the groundwater. We manufacture fire extinguishing wells for suction operation according to DIN 14220.

Product characteristics

Fire extinguishing wells type	Key figure	Yield l/min
Small	400 S	400-800
Medium	800 S	800-1,600
Large	1600 S	More than 1,600



Technical illustration

No.	Description
1	Fixed coupling with end cap pursuant to DIN 14319
2	Suction pipe with predetermined breaking point
3	FFR piece reduced
4	Flange pipe with transition to PVC well pipe DIN 4925
5	PVC casing DIN 4925
6	PVC screen pipe DIN 4925
7	PUR bottom cap

not illustrated

	Fixed coupling with end cap pursuant to DIN 14319 – Version B
	FF piece DN 125
	N piece DN 125 with connection for automatic discharge valve for suction or pressure operation
	K gate valve DN 125
	Installation kit for gate valves telescopic 1.0 m-1.5 m
	Fixed coupling



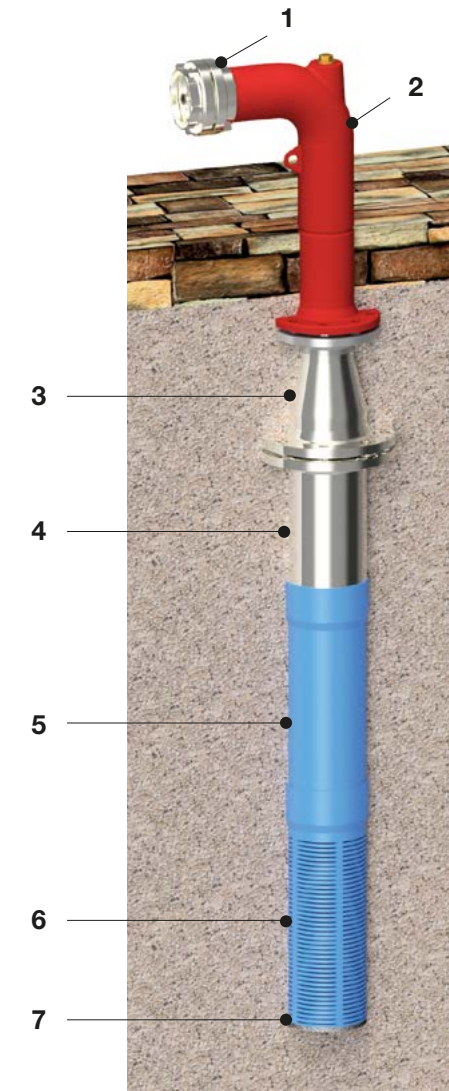

Additional products and information on request





Accessories

Bottom caps/closure elements

			
Bottom cap (natural) pursuant to KTW-BWGL	Bottom cap (black)	PVC/PE bottom cap pursuant to KTW-BWGL	Closure plug with sealing ring
DN 35–DN 175	DN 35–DN 100	DN 200–DN 600	DN 100–DN 400
Polypropylene	Polystyrol	PVC pipe with PE base	PU, foam rubber

			
Lower end piece of a measurement point with trapezoidal male thread	Closure element made of PVC-U (welded plastic base made of PVC-U)	Gauge pipe closure cap SEBA/HT with and without lock	Closure cap with upper end piece, optionally with female or male thread
DN 65–DN 125	DN 80–DN 600	DN 40–DN 150	DN 100–DN 200 larger on request
PVC-U solid material	PVC-U	Steel	PVC-U



Well heads

	
GWE K well head for riser pipe connection R 1"–4"	GWE K insertion well head for riser pipe connection R 1"–1.5"
DN 80–DN 300	DN 80–DN 125
PVC-U/PU	PU

Joints

These are required in order to enlarge the diameter of the pipework, e.g. in the transition from the screen to the casing section. For stability reasons, however, the ratio of the diameter to be bridged should not be larger than 1.5. For the

transition from PVC casings and screens to steel pipes, e.g. with the help of API threads, special interlink seating pieces are available.

	
SBF-NORIP joint for connection of unequal nominal widths (screen to casing section)	Socketed joint
Please indicated desired nominal combination	Graduations and structural lengths by request
PVC-U	PVC-U

Adapters

Adapters are used to connect two pipes with the same nominal width but different connection types.

Examples: Trapezoidal thread to pipe thread, thread to adhesive socket or male thread on both sides. Additional models available for delivery by request.

		
Adapter Structural length of 0.5 m or 1 m	Adapter Structural length 1 m	Steel protective pipe with wall anchor Structural length 1.5 m
DN 35–DN 175	DN 50–DN 100, DN 125, DN 150	DN 50, DN 100, DN 150
PVC pipe	Steel, galvanized	Steel

Guides

			
PP guide blades	PVC pipe guides	Steel pipe guides for PVC casings	PE-HD guides in segment construction for DN 150–400 mm
DN 50–DN 400	DN 100–DN 400	DN 300–DN 600	DN 65, DN 80, DN 100, DN 125, DN 150, DN 200
Polypropylene	PVC	Steel	Polyethylene

Fastening strap

GWE fastening strap acc. to ELL for riser pipes
DN 50–DN 250
EPDM

Collision protection

	
Protective triangle red/white	Tree guard bar
Width: 800 mm Height: 1,200 mm	Width: 1,000 mm Height: 1,120 mm
Steel, coated	Galvanized

Surface boxes



			
Cap for hydrants	Cap for waterworks valves	For valves of drilled fittings	For water/long-distance energy
DIN 4055 Weight: ~29.5 kg Load Class A 15	DIN 4056 Weight: ~13.4 kg Load Class A 15	DIN 4057 Weight: ~9 kg Load Class A 15	Similar to DIN 3583 Weight: ~54 kg Load Class A 15
Cast iron	Cast iron	Cast iron	Cast iron

Installation tools for screen pipes and casings made of PVC-U

			
K lifting caps	Steel inserts for K lifting caps Weight force > 20 kN	Steel lifting caps for extreme loads and long-term use	Strap wrench
DN 50–DN 600	DN 100–DN 600	DN 175–DN 500	Dimensions DN 50–DN 500
PVC	Steel	Steel	Steel

		
Wooden retaining clamp	PU retaining clamp	Retaining clamp made of steel for gravel pre-packed screens
DN 165–DN 600	DN 40–DN 150	DN 50–DN 400
Wood with steel	PU	Steel

Special accessories

	
Profile seals	PAN filter sleeves
DN 100–DN 400 (according to DIN 4925) DN 500–DN 600 (according to company standard on consultation)	DN 50–DN 300
Hose made of Dralon-T, acrylic homopolymer fiber	



2. Steel well materials

Product overview	52
Specialist knowledge	54
Well materials made of stainless steel	56
Well materials with HAGULIT® coating	64
Bridge slotted screens for dewatering	67
Installation tools	68





➔ For well heads see Well covers section,
Page 194

➔ For accessories see Well covers section,
Page 200

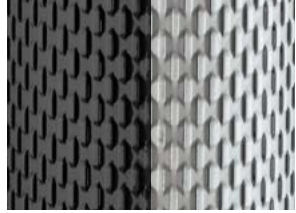

Access current information about
the product area online

Steel well materials

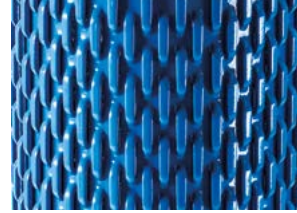
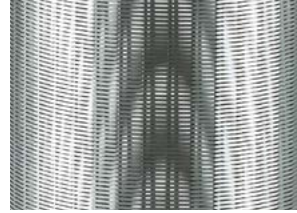
	Casing in stainless steel	PureLine Aseptic well pipe system	Bridge slotted screens black/galvanized	Bridge slotted screens Stainless steel	Bridge slotted screens HAGULIT®	Wire-wrapped screen Stainless steel
Product	 <p>DN 100–1200</p>	 <p>DN 300</p>	 <p>DN 150–800</p>	 <p>DN 200–1200</p>	 <p>DN 200–800</p>	 <p>DN 50–1200</p>
Product type	Stainless steel in material qualities 1.4301/1.4307; 1.4404/1.4571	Stainless steel in material qualities 1.4301/1.4307; 1.4404/1.4571	Black steel / Steel, galvanized	Stainless steel, stained and passivated	Black steel with HAGULIT® coating; KTW (drinking water plastic) approval	Stainless steel in material qualities 1.4301 and 1.4571 as well as special materials
	ZSM, flange, Thread on request	Chambered trapezoidal thread with double sealing system	Round thread, welding strap, screw strap	ZSM, round thread, flange connection, gravel coating possible	ZSM, flange connection, gravel coating possible	ZSM, flange or trapezoidal thread
Application	Standard product according to DIN 4925 as well as GWE company standard	Well materials for the drinks industry with the strictest requirements in hygiene and sterility.	Temporary well for dewatering and lowering groundwater level for longer periods of construction activity or recurring use	Well for drinking water supply. Large installation depths possible depending on diameter and wall thickness, as well as large diameters for dry drilling	Well for drinking water supply. The HAGULIT® coating is particularly resistant against aggressive water, sea water; very high chlorine resistance	Screen pipe for high water needs and geology with fine sand. Large installation depths possible depending on the model. Made of high-alloyed stainless steel: Use in highly aggressive water, sea water, high chlorine content and temperatures
Product benefits	Optimal and easy-to-install solution for the construction of wells for water extraction	Effective prevention of germ formation and buildup thanks to particularly smooth interior surface, no standing water zones. Food grade pursuant to Regulation (EC) No.1935/2004	Value for money	Installation depth, Diameter	Resistance	Filter capacity, Resistance

Stainless steel material

For many years, stainless steel has been considered the ideal material for multi-year use in untreated water and drinking water applications. While corrosion resistance and mechanical strength coupled with good availability are primary focal points, it is also important to pay close attention to the selection of materials and professional processing.

Nowadays there is an almost unlimited variety of stainless steel types, some of which vary significantly in their compositions and thus also in their characteristics. As a rule, alloyed steels with a chromium content of at least 10.5% and a carbon content of less than 1.2% are considered to be stainless steels. The corrosion resistance of stainless steel results exclusively from the formation of a dense and resistant chromium oxide layer on the surface of the steel. A high chromium content is essential for this purpose. In combination with oxygen, the passive coating generally reforms after being damaged as soon as

the surface is metallically pure and a sufficiently high chromium content is provided. Damages involving ferritic steel cause breaches and contamination of the passive coating and need to be avoided as a rule.

By means of mechanical or thermal processing, e.g. welding, the uppermost material layers can be contaminated by iron oxide, extraneous ferrite, scale, tarnish etc. and must be loosened and then removed by brushing, grinding, polishing or staining. The passive coating forms when rinsing with water or from the air.

In water management and particularly water well construction, the standard material alloys are used predominantly with the still common designations V2A and V4A, the most important examples of which are listed in the following table.

Steel type				Chemical composition in mass %				
Material no.	EN short name	Intern. designation (AISI)	Other designation	C	Cr	Mo	Ni	Other
1.4301	X5CrNi 18 10	304	V2A	≤0.07	17.5/19.5	-	8.0/10.5	
1.4306	X2CrNi 19 11	304L		≤0.03	18.0/20.0	-	10.0/12.0	
1.4307	X2CrNi 18 9	304L		≤0.03	17.5/19.5	-	8.0/10.5	
1.4401	X5CrNiMo 17 12 2	316	V4A	≤0.07	16.5/18.5	2.0/2.5	10.0/13.0	
1.4404	X2CrNiMo 17 13 2	316L		≤0.03	16.5/18.5	2.0/2.5	10.0/13.0	
1.4435	X2CrNiMo 18 14 3	316L		≤0.03	17.0/19.0	2.5/3.0	12.5/15.0	
1.4571	X6CrNiMo 17 12 2	316Ti		≤0.08	16.5/18.5	2.0/2.5	10.5/13.5	Ti ≥ 5 x % C

The physical characteristics of the listed steel types are nearly identical.

For normal water, the standard steels 1.4301, 1.4306 or 1.4307 are generally used. In cases of higher chloride ion content, molybdenum-alloyed higher-quality materials are preferred. A strategic material selection is essential for reliable prevention of corrosion.

The steel type is thus generally selected according to the required corrosion resistance, and in some cases depending on the current availability. In conclusion to all the previous work

steps, we carry out a professional surface treatment of all completed goods and products made from stainless steel. Staining is carried out using the latest methods in our in-house facility. In this way, we can guarantee you that the quality of our stainless steel products is faultless.

Experience, advanced technology and thorough knowledge ensure the best product characteristics for you. Optimized warehousing and high flexibility in manufacturing offer you a decisive time advantage regarding the availability of our products.

HAGULIT® coating

The HAGULIT® coating is based on our years of experience in manufacturing corrosion-resistant steel products for water well construction.

The epoxy resin powder which has been used millions of times as a coating for large industrial fittings and formed pipe parts was specially adapted and optimized for the coating method we rely on. All HAGULIT® products are manufactured using our advanced coating method of whirl sintering and are thus subject to predefined process parameters. After powder application by fully submerging the components into the whirl sintering bath, temperature-controlled tempering is carried out on the product to fully interlink the epoxy powder. This unique manufacturing method results in uniformly high coating quality.

Anywhere that higher-alloyed or high-alloyed special stainless steels need to be used because of the water quality, products coated with HAGULIT® offer an attractive alternative with excellent value for money.

HAGULIT® is a thermosetting plastic with the following benefits:

- Hygienic approval according to the current KTW-BWGL
- Single-layer structure without additional adhesive agents
- Enhanced impact resistance
- High surface hardness
- Temperature range for use -30 °C to +80 °C
- High chemical resistance even to conventional cleaning and regeneration products
- No infiltration of coating in case of free corrosion

For more details, our technical data sheets and product instructions are available on the following pages.



Well materials made of stainless steel – Stainless steel wire-wrapped screen

Product description

The wire-wrapped screens are adapted individually to your construction project to ensure maximum filter performance according to the characteristics of the aquifer. They are characterized by their high mechanical resistance coupled with a large open area.

Product characteristics

- Material: Stainless steel 1.4301 or 1.4571/1.4404 (Higher-alloyed materials on request)
- Structural length: 1 to 6 m
- Connection type: ZSM, trapezoidal thread and flange (special connections on request)
- Mesh widths: 0.1 mm or larger (different mesh widths can be manufactured continuously within a pipe length)
- Special designs possible (inverse winding, intermediate sizes, combination pipes with casing and screen pipe sections, special wire combinations)



Benefits

- Open area of up to 70% possible with corresponding design
- Reduction of drilling diameter, since a gravel filling is not required
- Installation depths up to 3,000 m possible with corresponding design
- Secure against siltation due to very good flow characteristics
- Very good regeneration properties thanks to triangular shape of wire wrap

Capacity as a function of mesh width and diameter

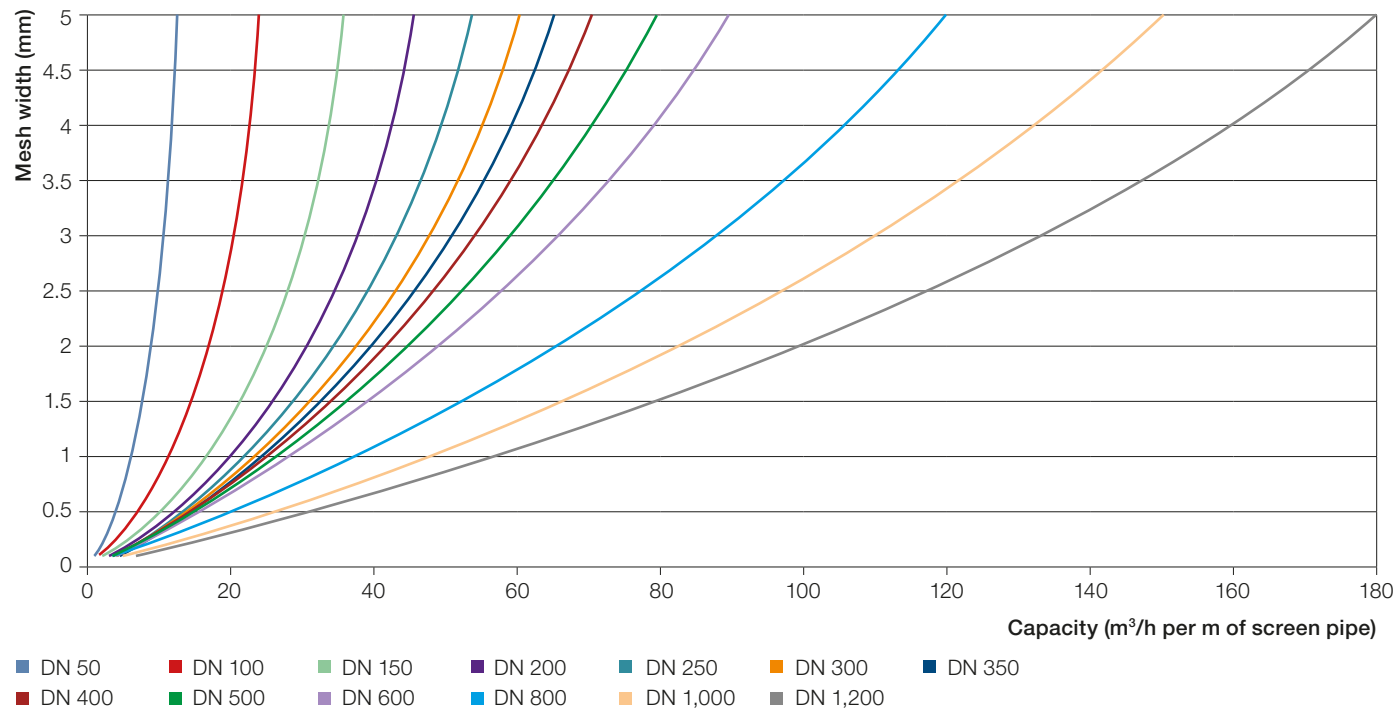

Technical data of selected screens

DN	Internal/external Ø mm	Load-bearing capacity KN	Capacity with V = 3 cm/s (m³/h per linear m of WWS)	Weight kg/m	External compressive strength bar
50	52/62	15	8	3.0	170.0
100	99/109	25	15	4.55	31.3
150	150/162	31	22	7.41	18.1
200	199/212	42	27	11.31	12.9
250	254/269	52	29	18.4	13.8
300	300/319	111	32	27.99	12.7
350	340/360	129	33	35.68	12.9
400	388/410	148	35	46.14	13.2
500	490/519	236	37	76.67	13.8
600	590/622	265	40	102.8	12.0
800	790/822	375	54	137.39	5.2
1,000	990/1,022	346	67	163.81	2.7
1,200	1,190/1,219	519	81	178.0	1.07

Differing structural requirements, such as mesh width or external compressive strength, alter the data listed in the table. In accordance with DIN 4900, the recommended maximum installation depth can be derived at 0.07 bar/m. Note: The values listed in the table/graphic correspond to a specific well configuration and are therefore only intended as an orientation aid. We are happy to determine the technical data for your specific application.



GWE pickling shop – Get in touch with us!

Well materials made of stainless steel – Casing in stainless steel

Product description

Casings according to DIN 4900-1 and GWE works standard represent an optimal and easy-to-install solution for the construction of wells for water extraction.

Product characteristics

- Material: Stainless steel, stined and passivated
- Alloys: 1.4301/1.4307; 1.4404/1.4571
other alloys available by request
- Structural length: 1 to 6 m
- Connection type: ZSM: DN 100 to DN 600 (DN 800)
Flange: DN 500 to DN 1,200
Thread: on request



Technical data

DN*	Outer pipe diameter mm	Wall thickness mm	Max. outer diameter mm	Load-bearing capacity ZSM kN
100	114.3	3	140	80
125	139.7	3	178	80
150	168.3	3	190	100
200	219.1	3	240	150
250	273	4	296	200
300	323.9	4	350	250
350	355.6	4	390	250
400	406.4	5	440	300
500	508	6	536	350
600	610	6	656	350
800	802	8	906	Flange
1,000	1,016	8	1,119	Flange
1,200	1,220	10	1,323	Flange

Other wall thicknesses according to static requirements

*Other pipe dimensions and connection systems on request

External compressive strength

DN	Wall thickness mm					
	3	4	5	6	8	10
External compressive strength N/mm						
100	5.8	14.9	-	-	-	-
125	3.2	8.2	16.8	-	-	-
150	1.8	4.7	9.6	17.1	-	-
200	0.8	2.1	4.3	7.7	19.1	-
250	0.4	1.1	2.2	4.0	9.9	-
300	0.3	0.7	1.3	2.4	5.9	-
350	0.2	0.5	1.0	1.8	4.5	-
400	0.1	0.3	0.7	1.2	3.0	6.0
500	0.1	0.2	0.3	0.6	1.5	3.1
600	-	0.1	0.2	0.4	0.9	1.8
800	-	-	0.1	0.2	0.4	0.8
1,000	-	-	-	0.1	0.2	0.4
1,200	-	-	-	-	0.1	0.2

Calculated values for elastic buckling according to AD 2000 – leaflet B6 - formula 3 -without guarantee-. Additional safety factors must be taken into account for this application. 1 N/mm² corresponds to 10 bar.

Pipe weight

DN	Wall thickness mm					
	3	4	5	6	8	10
Weight kg/m						
100	8.4	11.1	-	-	-	-
125	10.3	13.6	16.8	-	-	-
150	12.4	16.4	20.4	24.4	-	-
175	14.3	19.0	23.6	28.2	-	-
200	16.2	21.5	26.8	32.0	42.2	-
250	20.3	26.9	33.5	40.1	53.1	-
300	23.9	32.1	39.9	47.8	63.3	-
350	26.3	35.2	43.8	52.5	69.6	-
400	30.2	40.1	50.2	60.2	79.8	99.3
500	37.8	50.2	62.6	75.4	100.2	124.7
600	-	60.4	75.3	90.7	121.0	150.1
800	-	-	99.1	118.7	157.0	196.0
1,000	-	-	-	150.6	201.9	252.9
1,200	-	-	-	-	242.8	303.0

Well materials made of stainless steel – PureLine

Product description

The specially developed GWE PureLine® aseptic well pipe connection, designed to be seamlessly free of gaps and dead space, is manufactured with the highest quality materials and finishes. The GWE PureLine® aseptic well pipe connection is fully ground, stained and passivated on the inside. Thanks to the minimized possibility of infiltration and the capacity to entirely remove residues, contamination with particles and germs is prevented from the very beginning.



Product characteristics

- Material: Stainless steel, stained and passivated
- Alloys: 1.4301/1.4307; 1.4404/1.4571
- Special grind: Interior Ra < 0.8 µm complete
- Connection type: Chambered trapezoidal thread with double sealing system (flat seal PTFE and O-ring)
- Tightening torque marking for correct torque during connection
- Structural length: 1.0 m, 2.0 m, 3.0 m, 4.0 m, 5.0 m, 6.0 m

Benefits

- Specially developed double sealing system for the strictest requirements in hygiene and sterility
- Highly-precise manufacturing, e.g. special grind on interior
- Effective prevention of germ formation and buildup thanks to particularly smooth interior surface, no standing water zones
- Food grade pursuant to Regulation (EC) No. 1925/2004

Technical data

External diameter* Connection mm	Internal diameter mm	Installation depth m	Load-bearing capacity casing kN	Weight kg/linear meter
344	311	up to 400	300	55

*other dimensions available by request

Packaging

Pipes with the GWE PureLine® connection are delivered in sterile packaging.

Well materials made of stainless steel – Stainless steel gravel pre-packed screens

Product description

GWE gravel pre-packed screens made of stainless steel consist of the actual bridge slotted screen pipe as well as an additional permanently attached sheath made of filter gravel. Advantage: a particularly uniform gravel particle distribution enables use for drilling applications where normal gravel filling is difficult to implement.

GWE exclusively uses particularly high-quality filter gravel according to DIN/EN and epoxy resin certified for drinking water as an adhesive.



Product characteristics

- Material: Bridge slotted screens made of stainless steel (1.4301, 1.4541, 14571)
- Mesh: Bridge slot mesh 2.0 +/- 0.4 according to DIN 4900
- Graining: 1–2 mm, 2–3 mm, 3–5 mm, 4–7 mm
- Gravel coating: Above the bridge slot at least 15 mm quartz gravel
- Connection type:
 - ZSM: DN 200 to DN 600
 - Flange: DN 500 to DN 800
- Structural length: 1 m, 2 m

Benefits

- Particularly uniform gravel particle distribution
- Effective use for drilling with small diameters
- Minimized risk of sand entering the well

Technical data

DN*	Outer pipe diameter mm	Wall thickness mm	External diameter over the gravel sheath mm	Load-bearing capacity ZSM kN	Weight kg/m	Open area screen pipe %
200	219	4	265	150	126	16
250	273	4	315	200	160	16
300	324	4	365	250	183	16
350	356	4	415	250	210	16
400	406	5	470	300	267	12
500	508	6	570	350	363	12
600	610	6	675	350	463	12
800	802	8	870	Flange	672	12

*Customized products available by request

Well materials made of stainless steel – Stainless steel bridge slotted screens

Product description

Bridge slotted screens according to DIN 4900-1 and GWE works standard represent an optimal and easy-to-install solution for the construction of wells for water extraction.

Product characteristics

- Material: Stainless steel, stained and passivated
- Alloys: 1.4301/1.4307; 1.4404/1.4571
other alloys available by request
- Structural length: 1 to 6 m
- Connection type:
 - ZSM: DN 200 to DN 600
 - Flange: DN 500 to DN 1,200
 - Thread: on request
- Bridge slot opening: 1.0 to 3.0 mm
- Special features: Screens can be encased with gravel



Technical data

DN*	Outer pipe diameter mm	Wall thickness mm	Further wall thicknesses according to static requirements	Open area in % with bridge slot opening h = 2.5 mm	Max. outer diameter mm	Load-bearing capacity ZSM kN
200	219.1	3		23.5	240	150
250	273	4		16	296	200
300	323.9	4		16	350	250
350	355.6	4		16	390	250
400	406.4	5		15	440	300
500	508	6		14	536	350
600	610	6		14	656	350
800	802	8		13	906	Flange
1,000	1,016	8		13	1,119	Flange
1,200	1,220	8	13	1,323	Flange	

*Other pipe dimensions and connection systems on request

Screen weight

DN	Wall thickness mm					
	3	4	5	6	8	10
Weight kg/m						
200	16.2	21.5	26.8	32.0	42.2	-
250	20.3	26.9	33.5	40.1	53.1	-
300	23.9	32.1	39.9	47.8	63.3	-
350	26.3	35.2	43.8	52.5	69.6	-
400	30.2	40.1	50.2	60.2	79.8	99.3
500	37.8	50.2	62.6	75.4	100.2	124.7
600	-	60.4	75.3	90.7	121.0	150.1
800	-	-	99.1	118.7	157.0	196.0
1,000	-	-	-	150.6	201.9	252.9
1,200	-	-	-	-	242.8	303.0



GWE installation service – Get in touch with us!

Well materials with HAGULIT® coating – HAGULIT® bridge slotted screens and casings

Product description

Bridge slotted screens and casings with HAGULIT® coating are manufactured in accordance with DIN 4900-1 and combine strong physical properties with outstanding economic attractiveness.

The HAGULIT® epoxy resin coating, certified for drinking water, is characterized by high chemical and mechanical resistance. This combination offers a product for the most demanding requirements.

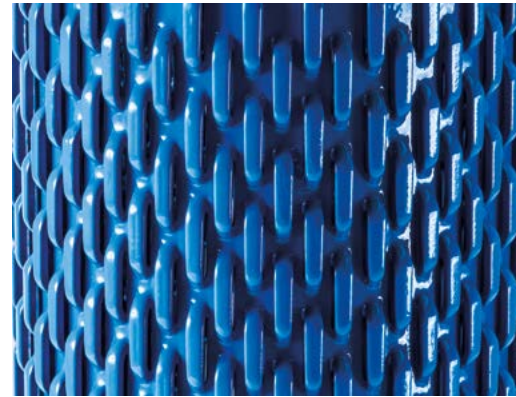

Product characteristics

- Material: Steel (S235JR) with HAGULIT® coating
- Structural length: 1 to 5 m
- Connection type:
 - ZSM: DN 200 to DN 600
 - Flange: DN 500 and DN 800
- Bridge slot opening: 2.0 mm +/- 0.4 mm (coated)

Benefits

- Maximum corrosion protection, infiltration-proof coating
- Exceptional abrasion resistance and impact strength of the HAGULIT® coating
- Corrosion resistance against water with a high chloride content
- Application range up to max. 80° C media temperature
- Bridge slotted screens can be provided with a factory-applied gravel coating

Technical data

DN*	Outer pipe diameter mm	Wall thickness mm	Max. outer diameter mm	Load-bearing capacity ZSM KN	Weight kg/m	Open area of filter pipes %
200	219	4	261	150	31	16
250	273	4	315	200	36	16
300	324	4	368	250	47	16
350	356	4	408	250	54	16
400	406	5	458	300	70	12
500	508	6	556	350	110	12
600	610	6	656	350	116	12
800	802	8	906	Flange	163	12

Further wall thicknesses according to static requirements

*Other pipe dimensions and connection systems on request

Chemical resistance

Substances	Concentration mg/l
Free carbon dioxide	1,000
Total salt content (without NaCl)	5,000
Sodium (Na+)	20,000
Calcium (Ca++)	1,000
Magnesium (Mg++)	1,000
Potassium (K+)	250
Chloride (Cl-)	20,000
Hydrogen carbonate (HCO ₃)	2,000
Sulphate (SO ₄ --)	2,000

Upper limit of substances listed at a pH value of 5.5-8.0 and 50 °C media temperature

External compressive strength -casings-

DN	Wall thickness mm			
	4	5	6	8
	External compressive strength N/mm ²			
200	2.1	4.3	7.7	-
250	1.1	2.2	4.0	-
300	0.7	1.3	2.4	-
350	0.5	1.0	1.8	-
400	-	0.7	1.2	-
500	-	0.3	0.6	1.5
600	-	0.2	0.4	0.9
800	-	0.1	0.2	0.4

Calculated values for elastic buckling according to AD 2000 – leaflet B6 - formula 3 -without guarantee-
Additional safety factors must be taken into account for this application
1 N/mm² corresponds to 10 bar

Well materials with HAGULIT® coating – Steel gravel pre-packed screens with HAGULIT® coating

Product description

GWE gravel pre-packed screens made of steel with HAGULIT® coating consist of the actual bridge slotted screen pipe with HAGULIT® coating as well as an additional permanently attached sheath made of filter gravel. On the one hand, the factory-applied gravel coating enables use for drilling applications where normal gravel filling is difficult to implement, and on the other hand it considerably simplifies the implementation of a double gravel filling.

GWE exclusively uses particularly high-quality filter gravel according to DIN 4924 and epoxy resin certified for drinking water as a binding agent.



Product characteristics

- Material: Bridge slotted screen made of steel S355J with HAGULIT® coating
- Mesh: Bridge slot mesh 2.0 +/- 0.4 according to DIN 4900
- Graining: 1–2 mm, 2–3 mm, 3–5 mm, 4–7 mm
- Gravel coating: Above the bridge slot at least 15 mm quartz gravel
- Connection type:
 - ZSM: DN 200 to DN 600
 - Flange: DN 500 and DN 800
- Structural length: 1 m, 2 m

Technical data

DN*	Outer pipe diameter mm	Wall thickness mm	External diameter over the gravel sheath mm	Load-bearing capacity ZSM kN	Weight with coating kg/m	Open area of filter pipes %
Other wall thicknesses according to static requirements						
200	219	4	265	150	128	16
250	273	4	315	200	162	16
300	324	4	365	250	185	16
350	356	4	415	250	212	16
400	406	5	470	300	271	12
500	508	6	570	350	366	12
600	610	6	675	350	465	12
800	802	8	870	Flange	676	12

*Customized products available by request

Bridge slotted screens for dewatering

Product description

The steel bridge slotted screens for dewatering are extremely robust and withstand impacts and shocks without any restriction of their functional capacity.

Product characteristics

- Material: Steel raw black (rh) / galvanized (vz)
- Structural length: 1.5 m and 3 m (special lengths on request)
- Connection type:
 - Welding strap: DN 150 to DN 800 (rh)
 - Screw strap: DN 150 to DN 800 (rh/vz)
 - Round thread: DN 200 to DN 400 (rh/vz)
- Bridge slot opening: 0.8/1.7 mm (rh)
0.6/1.5 mm (vz)
(Additional bridge screen heights on request)

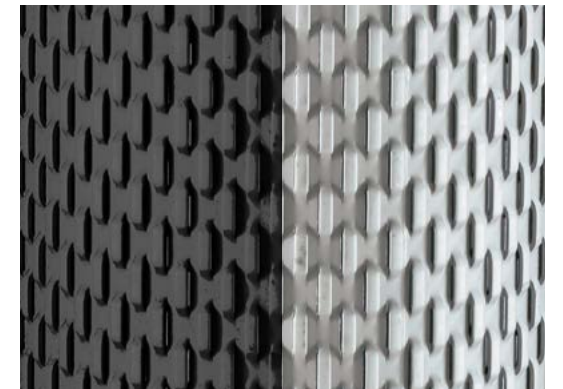

Benefits







- Robust design
- Strength and toughness

Technical data

DN	Wall thickness mm	External Ø mm	Internal Ø mm	External Ø over spigot socket mm	Weight kg/m	Permissible tensile stress kN (Round thread)
150	3	168	162	195	12	-
200	3	219	213	250	16	85
250	3	273	267	305	20	120
300	3	325	319	352	24	170
300	4	325	317	352	32	240
350	4	368	360	395	36	280
400	4	406	398	433	40	320
500	4	500	492	510	49	-
600	4	600	592	610	59	-
700	4	700	692	710	69	-
800	4	800	792	810	79	-

Due to the molded round thread connection, structural lengths are reduced by up to 120 mm per pipe.

Installation tools for well materials steel

			
Lifting tap ZSM DN 100–DN 500	Lifting flange DN 500–DN 1,000	Lifting tap thread Custom design thread	Retaining clamp DN 100–DN 800
Lifting tap for well materials according to DIN 4900	Lifting flange for well materials according to DIN 4900	Various custom designs on request	Retaining clamp for well materials according to DIN 4900 (Other dimensions available on request)
			
Lifting tap ZSM DN 32–DN 300	Lifting cap ZSM DN 32–DN 300	Lifting cap EcoConnect DN 50–150	Retaining clamp DN 32–DN 300
Lifting tap for riser pipes according to DIN 4945 and GWE company standard	Lifting cap for riser pipes according to GWE company standard	Lifting cap for riser pipes EcoConnect system	Retaining clamp for riser pipes

Additional models and sizes on request.

- ➔
- For well heads see Well covers section, Page 196
 - For accessories see Well covers section, Page 202





3. Riser pipes

Product overviews	72
Specialist knowledge	76
Pump riser pipes stainless steel	78
Pump riser pipes plastic	88
Pump riser pipes with coating	90

➔ For formed parts see Well covers section,
Page 200









Access current information about
the product area online

Pump riser pipes stainless steel

	EcoConnect®	Flange	ZSM DIN 4945-2	ZSM GWE – company standard	ZSM PN 40 GWE – company standard	PN 100 Highly tension- resistant connection
Product			 2 sealings Shear spring	 1 sealing 1 shear spring	 2 sealings 2 shear springs	 2 sealings 2 link chains
Product type	Molded ZSM connection	Flange connection according to DIN 4927	ZSM connection in line with DIN 4945-2	ZSM connection according to GWE company standard	ZSM connection according to GWE company standard	Highly tension-resistant ZSM connection according to GWE company standard
	DN 50–200	DN 50–250	DN 40–250	DN 40–250	DN 50–250	DN 150–300
	PN 16	PN 16	PN 25	PN 25	PN 40	PN 100
Application	Use in irrigation wells, agricultural irrigation or for private home water supply	Classic product for use in wells with sufficiently large internal diameters and maximum maintenance intervals for submersible pumps	Standard product ac- cording to DIN 4945-2 with increased permis- sible excess operating pressure, suitable for use in nearly all wells for water supply	Use in wells for water supply. Design and installation method of- fer benefits with regard to drinking water hygiene and dismantling under highly fluctuat- ing water levels	Use in deep wells for water supply or for pumps with higher driver power and pump head	For high-performance require- ments at particularly great depths. Ideal for mining and geothermal energy applica- tions with large string weights
Product benefits	Value for money	Reliability	Quick installation	Quick installation (Tap on top, spigot socket on bottom)	Quick installation High load-bearing capacity	High installation depths High tensile strength Proven connection technology
	Slim connection (Tap on top, spigot socket on bottom)	Other dimensions and pressure classes possible	DIN-compatible	Spigot socket points down, optimal residual water runoff		

Riser pipes PVC/steel

	SBF-SECA®	HAGULIT® Flange	HAGUDOSTA® PN 16	HAGULIT® Hybrid PN 25	HAGULIT® Hybrid PN 40	HAGUTHERM®
Product			 2 sealings 2 POM shear rods	 1 sealing 1 shear spring	 2 sealings 2 shear springs	
Product type	PVC-U Thread connection with rotation lock	HAGULIT® Flange connection according to DIN 4927	HAGULIT® ZSM connection according to DIN 4945-1	HAGULIT® ZSM connection according to GWE company standard	HAGULIT® ZSM connection according to GWE company standard	Rubber-coated with sharp-thread connection according to GWE company standard
	DN 40–80	DN 40–250	DN 50–250	DN 40–250	DN 50–200	DN 125–200
	PN 10	PN 16	PN 16	PN 25	PN 40	PN 40
Application	Use in irrigation wells, for agricultural irrigation or for private home water supply.	Use in wells with sufficiently large internal diameters and maximum maintenance intervals.	Standard product suitable for use in wells for water supply.	Due to increased permissible excess operating pressure, suit- able for use in nearly all wells for water supply.	Use in deep wells for water supply or for pumps with higher driver power and pump head.	Use in geothermal energy wells with highly mineralized water with a high chloride content
The HAGULIT® and HAGUTHERM® coatings enable use in highly mineralized water with a high chloride content.						
Product benefits	Installation depth max. 100 m	Reliability	Easy installation	Increased load-bearing capacity	High load-bearing capacity	Temperature resistance up to 100 °C
	Slim connection	Other dimensions and pressure classes possible	Slim connection	Slim connection	Slim connection	High load-bearing capacity

The right design for riser pipes

Our expert shows that insufficient attention is often dedicated to the selection and dimensioning of riser pipes, meaning that potential cost savings are not exploited as a result or difficulties can even arise during operation.

“The unique installation situation of riser pipes also results in particular requirements.”

This refers on the one hand to smooth handling of riser pipes when installing and dismantling submersible pumps after multiple years of operation, and on the other hand that riser pipes, in contrast to other pressure pipe systems, are sometimes subjected to considerable additional static and dynamic loads. In addition, the water to be pumped is generally located both inside and outside the pipe, which means that corrosion,

clogging and contamination can occur inside and out, potentially negatively impacting function.

As a result, riser pipes are considered special pipes that are not comparable to standard pressure pipes.

Design of pump riser pipes

First, the required diameter of the riser pipes must be determined based on the yield. Here it must be noted that the dimensioning of the riser pipes also has a considerable influence on the energy consumption of the pump. The following diagram provides an initial estimate. The more you approach the upper area of the curve, the larger the current velocity and the pipe friction losses. The lower area of the diagram represents the optimum situation with low pipe friction and energy losses.

Dimensioning of pump riser pipes

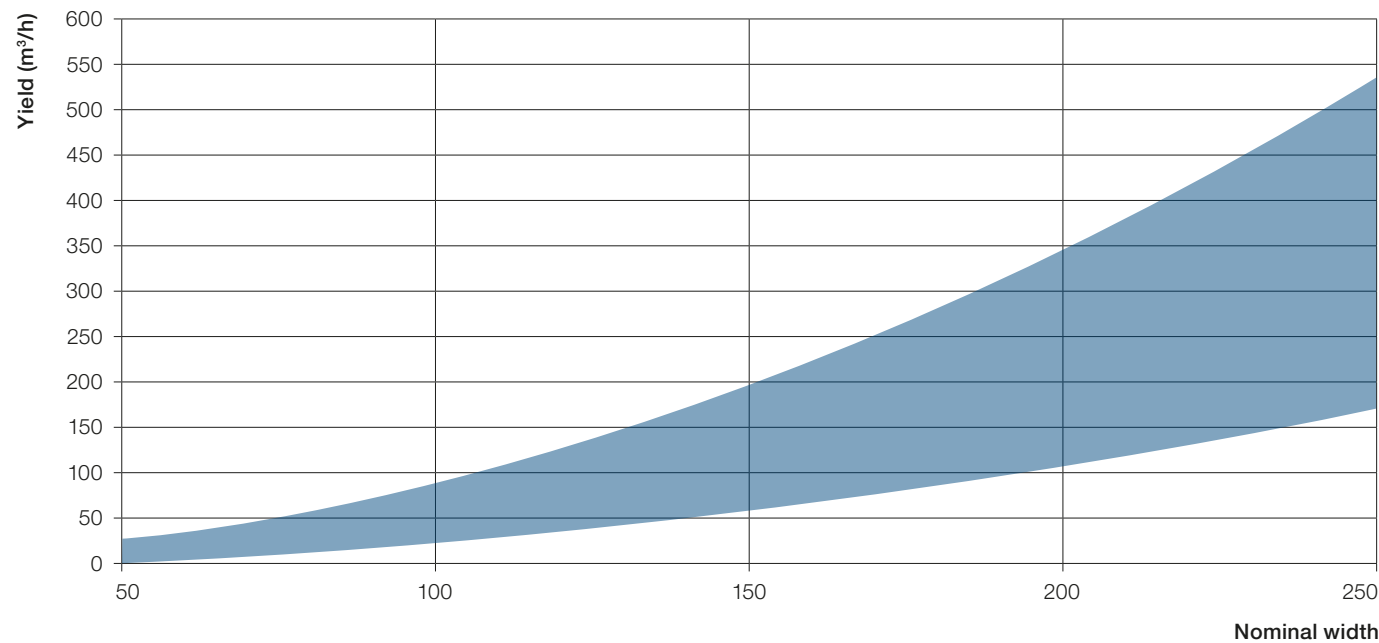

Other factors influencing the dimensioning include:

- Well diameter
- Diameter of submersible pump cable
- Installation depth and length of riser pipe
- Gauge pipes, measuring devices, sensors, etc.
- Redundancy or multiple pumps in one well

In the next stage, the riser pipes must be designed with regard to their load to suit the individual installation situation. Large installation depths, high levels of engine performance, high pump and cable weights have to be securely absorbed by the riser pipe.

The required input variables for the design calculation are:

- Installation depth and weight of submersible pumps and cables
- Pump pressure in operation and with closed gate valves

- Engine performance of submersible pump and initial starting torque
- Weight of water head and pipe string
- Pressure fluctuations when starting and stopping pump operation
- Lateral displacement from pump axis
- Oscillating movements in case of poorly fitting centering devices

The static and dynamic loads generated are calculated based on the input data and summarized into a reference stress in the form of a multi-axis stress analysis. Using the specific material's strength characteristics, the final design and dimensioning of the required riser pipe is then carried out.

Three systems, one goal

With the GWE riser pump systems depicted on the following pages, we are able to meet your individual requirements and offer you the optimal solution.



Our service

Custom design of the GWE riser pump systems as well as assistance and consulting during material selection: that is our service for you.

Berechnung von Pumpensteigrohren		
Pumpen und Steigrohrdaten		
Abmessung	DN	300
Material		1.4301
Außen Durchmesser	D_a	219,1 mm
Wandstärke	s_0	4,00 mm
zul. Vergleichsspannung	$\sigma_{v, zul}$	80,00 N/mm ²
Betriebsförderhöhe	H_B	200,00 m
Nullförderhöhe	H_0	500,00 m
Ertelstiefe	H_E	120,00 m
Pumpengewicht	G_P	1000,00 kg
Pumpenleistung	P_N	70,00 kW
Pumpendrehzahl	n	50,00 s ⁻¹
max. Drehmoment (Anlaufmoment)	M_A	557,04 Nm
Vergleichsspannung		
in Betrieb	$\sigma_{v, B}$	50,64 N/mm ²
bei Nullförderhöhe	$\sigma_{v, 0}$	121,75 N/mm ²
Belastungsfaktor		
in Betrieb	f_B	63,31 %
bei Nullförderhöhe	f_0	152,18 %
Resultierende Kraft in der Verbindung		
zulässige Zugkraft	$F_{z, zul}$	381,0 kN
Kraft in Betrieb	F_B	108,6 kN
Kraft bei Nullförderhöhe	F_0	211,8 kN
Entstehender Druck in der Verbindung		
zulässiger Druck	p_{zul}	49,0 bar
Druck in Betrieb	p_B	19,6 bar
Druck bei Nullförderhöhe	p_0	49,1 bar

Pumps and riser pipe data

Dimension	DN	300
Material		1.4301
External diameter	D_a	219.1 mm
Wall thickness	s_0	4.00 mm
permissible reference stress	$\sigma_{v, perm.}$	80.00 N/mm ²
Operating pump head	H_B	200.00 m
Shut-off head	H_0	500.00 m
Installation depth	H_E	120.00 m
Pump weight	G_P	1000.00 kg
Pump power	P_N	70.00 kW
Pump speed	n	50.00 s ⁻¹
max. torque (starting torque)	M_A	557.04 Nm

ACHTUNG: Die maximale Förderhöhe muss durch ein Druckregelgerät kontrolliert werden.

Pump riser pipes stainless steel – EcoConnect® riser pipe

Product description

Riser pipe with molded, tension-resistant push-fit sleeve connection for versatile applications in irrigation, agriculture, water supply and geothermal energy.

Product characteristics

- Material: Stainless steel
- Structural length: 1 to 6 m
- Connection type: molded ZSM with seal and steel spring
- Pressure rating: PN 16
- Max. installation depth: 160 m



Product characteristics

- Economical alternative to conventional riser pipes
- Low external diameter enables installation even in narrow wells
- Integrated rotation lock for secure absorption of pump start-up torque
- Fast and secure installation
- Selection of a wide range of stainless steel qualities for optimal corrosion resistance

Models

DN	Max. external Ø of spigot socket mm	External Ø pipe mm	Wall thickness mm	Weight kg/m	Permissible tensile/axial stress kN
50	81	60.3	2.0	2.9	50
65	96	76.1	2.0	3.7	65
80	112	88.9	2.6	5.6	80
100	140	114.3	3.0	8.3	100
125	166	139.7	3.0	10.2	125
150	193	168.3	3.0	12.5	160
200	251.3	219.1	3.0	16.24	-

Pump riser pipes stainless steel – Stainless steel riser pipe (flange)

Product description

The riser pipe with flange connection according to DIN 4927 is characterized by a welding neck flange attached on both sides pursuant to DIN 2633. Two recesses on the flange serve to accommodate the pump cable. As needed, gauge pipes, cable clamps or gauge pipe brackets can be welded on.



Product characteristics

- Stainless steel 1.4301 (V2A) and 1.4571 (V4A), additional material qualities on request
- Longitudinal seam-welded pipes in accordance with DIN EN 10217-7
- Structural length: 1 to 6 m
- Connection type: Flange connection
- Pressure rating: PN 16 (higher pressure ratings on request)

Benefits

- Reliability
- Hygienic safety
- High installation depths

Models

DN	Wall thickness mm	External Ø pipe mm	External Ø flange mm	Bolt circle Ø mm	Screws no. x thread
40	2.0	48.3	150	110	4 x M16
50	2.0	60.3	165	125	4 x M16
65	2.0	76.1	185	145	4 x M16
80	2.6	88.9	200	160	8 x M16
100	3.0	114.3	220	180	8 x M16
125	3.0	139.7	250	210	8 x M16
150	3.0	168.3	285	240	8 x M20
200	4.0	219.1	340	295	12 x M20
250	4.0	273	405	355	12 x M24

Weight

DN	1.0 m	2.0 m	3.0 m	4.0 m	5.0 m	6.0 m
40	6.1	8.4	10.7	13.1	15.4	17.7
50	8.0	10.9	13.8	16.7	19.7	22.6
65	9.8	13.5	17.2	20.9	24.6	28.3
80	13.0	18.6	24.2	29.8	35.5	41.1
100	17.6	26.0	34.3	42.7	51.0	59.4
125	22.9	33.1	43.4	53.7	64.0	74.2
150	28.7	41.9	55.1	68.3	81.5	94.7
200	43.5	65.0	86.5	108.0	129.5	151.0
250	60.5	87.4	114.4	141.3	168.3	195.2

The riser pipes are also available in galvanized steel or plastic-coated models

Pump riser pipes stainless steel – Riser pipe ZSM DIN 4945-2 PN 25

Product description

The riser pipe, with tension-resistant push-fit sleeve connection in accordance with DIN 4945-2, is defined by its sealing **with two O-rings and a stainless steel spiral spring** as a connecting element. The second O-ring in front of the shear spring prevents dirt from entering the connection gap and thus prevents the build-up of brackish water and contamination.

For installation, it is recommended to use a suitable lubricant with KTW (drinking water plastic) approval. This is carried out with the spigot socket pointing upwards. The stainless steel shear springs can be removed again during dismantling using the eyebolt included in the delivery. When removing and re-installing the riser pipe, the shear springs must be inspected for damages and the O-rings must be replaced.



Product characteristics

- Pressure rating PN25
- Stainless steel 1.4301 (V2A) and 1.4571 (V4A), additional material qualities on request
- Longitudinal seam-welded pipes acc. to DIN EN 10217-7
- ZSM with two O-rings and a shear spring (ZSM 201F)
- Standard structural lengths 1 to 6 m
- Installation direction with tap downwards and spigot socket upwards

Benefits

- Quick installation
- Slim connection
- Hygienic safety
- Short delivery periods

Dimensions

DN	Media pipe* d _R x s mm	Outer diameter spigot socket D _M mm	Shear spring mm			O-ring D _O x d _O mm	Tensile strength σ _Z kN
			d _S x s	L ₁	L ₂ **		
40***	48.3 x 2.0	69	5 x 1.25	150	180	48 x 4	40
50	60.3 x 2.0	85	7 x 1.50	205	215	60 x 5	50
65	76.1 x 2.0	102	7 x 1.50	265	275	77 x 5	65
80	88.9 x 2.6	115	7 x 1.50	280	310	88 x 5	80
100	114.3 x 3.0	139	7 x 1.50	350	385	110 x 5	100
125	139.7 x 3.0	165	7 x 1.50	445	470	136 x 5	125
150	168.3 x 3.0	198	9 x 1.80	535	560	166 x 6	150
200	219.1 x 4.0	249	9 x 1.80	690	720	215 x 6	200
250***	273.0 x 4.0	310	9 x 1.80	910	940	270 x 6	250

*Depending on availability, slightly deviating pipe wall thicknesses may be used

**Long shear spring design with projecting length on request

***Based on DIN 4945-2

Weights kg

DN	Set	Structural lengths					
		1.0 m	2.0 m	3.0 m	4.0 m	5.0 m	6.0 m
40	1.0	3.3	5.6	7.9	10.2	12.5	14.8
50	1.7	4.6	7.5	10.4	13.3	16.2	19.1
65	2.2	5.9	9.6	13.2	16.9	20.6	24.3
80	3.2	8.7	14.3	19.9	25.5	31.0	36.6
100	4.0	12.3	20.6	28.9	37.1	45.4	53.7
125	5.1	15.3	25.5	35.7	45.8	56.0	66.2
150	6.9	19.2	31.5	43.9	56.2	68.5	80.8
200	9.1	30.5	51.8	73.2	94.5	115.9	137.2
250	18.9	45.6	72.3	99.0	125.7	152.4	179.1

Weight determined on the basis of a calculation.



GWE installation service – Get in touch with us!

Pump riser pipes stainless steel – Riser pipe ZSM GWE-WN PN 25

Product description

The riser pipe, with tension-resistant push-fit sleeve connection in accordance with GWE company standard, is defined by its **sealing with an O-ring and a stainless steel spiral spring** as a connecting element. Due to the recommended installation direction, with tap facing upwards and spigot socket facing downwards, continuous and complete drainage of the connection is ensured in the area of fluctuating water levels. The build-up of brackish water and contamination in the connection gap is also prevented, as are potential deposits and incrustations that could cause problems when removing the riser pipe.



For installation, it is recommended to use a suitable lubricant with KTW (drinking water plastic) approval. The stainless steel shear springs can be removed again during dismantling using the eyebolt included in the delivery. When removing and re-installing the riser pipe, the shear springs must be inspected for damages and the O-rings must be replaced. To release the connection, an eyebolt is included in the delivery that can be used to remove the spiral springs.

Product characteristics

- Pressure rating PN25
- Stainless steel 1.4301 (V2A) and 1.4571 (V4A), additional material qualities on request
- Longitudinal seam-welded pipes acc. to DIN EN 10217-7
- Tension-resistant push-fit sleeve connection with an O-ring and a shear spring (ZSM 101F)
- Standard structural lengths 1 to 6 m
- Installation direction with tap upwards and spigot socket downwards

Benefits

- Quick installation
- Slim connection
- Hygienic safety
- Short delivery periods

Dimensions

DN	Media pipe* d _s x s mm	Outer diameter spigot socket D mm	Shear spring mm			O-ring D _o x d _o mm	Tensile strength σ _Z kN
			d _s x s	L ₁	L ₂ **		
32	42.4 x 2.0	63	5 x 1.25	133	145	42 x 4	32
40	48.3 x 2.0	69	5 x 1.25	150	180	48 x 4	40
50	60.3 x 2.0	85	7 x 1.5	205	215	60 x 5	50
65	76.1 x 2.0	102	7 x 1.5	265	275	77 x 5	65
80	88.9 x 2.6	115	7 x 1.5	280	310	88 x 5	80
100	114.3 x 3.0	139	7 x 1.5	350	385	110 x 5	100
125	139.7 x 3.0	165	7 x 1.5	445	470	136 x 5	125
150	168.3 x 3.0	198	9 x 1.8	535	560	166 x 6	150
200	219.1 x 4.0	249	9 x 1.8	690	720	215 x 6	200
250	273.0 x 5.0	310	11 x 2.2	920	950	270 x 6	250

*Depending on availability, slightly deviating pipe wall thicknesses may be used

**Long shear spring with slight overhang past the outer diameter of the spigot socket on request

Weights kg

DN	Structural lengths					
	1.0 m	2.0 m	3.0 m	4.0 m	5.0 m	6.0 m
32	2.9	4.9	6.9	9.0	11.0	13.0
40	3.2	5.5	7.9	10.2	12.5	14.8
50	4.4	7.3	10.3	13.2	16.1	19.1
65	5.5	9.2	13.0	16.7	20.4	24.1
80	8.2	13.8	19.4	25.1	30.7	36.4
100	11.1	19.3	27.4	35.5	43.6	51.7
125	14.2	24.2	34.2	44.1	54.1	64.1
150	18.2	30.7	43.1	55.6	68.0	80.5
200	29.1	50.8	72.4	94.0	115.6	137.3
250	44.9	78.6	112.3	146.0	179.7	213.3

Pump riser pipes stainless steel – Riser pipe ZSM GWE-WN PN 40

Product description

The riser pipe, with tension-resistant push-fit sleeve connection in accordance with GWE company standard, is defined by its use of **two O-rings and two stainless steel spiral springs** as connecting elements. While the second spiral spring increases the tensile strength of the connection, the second O-ring impedes dirt from entering the connection gap and prevents the connection from becoming stuck.

For installation, it is recommended to use a suitable lubricant with drinking water certificate. When removing and reinstalling the riser pipe, the shear springs must be inspected for damages and the O-rings must be replaced. The shear springs can be removed again during dismantling using the eyebolt included in the delivery.



Product characteristics

- Pressure rating PN40
- Stainless steel e.g. 1.4301/AISI 304, 1.4571/AISI 316 or additional material qualities on request
- Longitudinal seam-welded pipes acc. to DIN EN 10217-7
- ZSM with two O-rings and two shear springs (ZSM 2O2F)
- Standard structural lengths 1 to 6 m
- Direction of installation: Tap downwards and spigot socket upwards

Benefits

- Quick installation
- Slim connection
- Hygienic safety
- High installation depths
- Short delivery periods

Dimensions

DN	Media pipe* d _R x s mm	Outer diameter spigot socket D _M mm	Shear spring mm			O-ring D _o x d _o mm	Tensile strength σZ kN
			d _s x s	L ₁	L ₂ **		
40	48.3 x 2	69	5 x 1.5	150	160	48 x 4	-
50	60.3 x 2.0	85	7 x 1.5	205	215	60 x 5	75
65	76.1 x 2.0	102	7 x 1.5	265	275	77 x 5	100
80	88.9 x 2.6	115	7 x 1.5	280	310	88 x 5	130
100	114.3 x 3.0	139	7 x 1.5	350	385	110 x 5	160
125	139.7 x 3.0	165	7 x 1.5	445	470	136 x 5	190
150	168.3 x 3.0	198	9 x 1.8	535	560	166 x 6	230
200	219.1 x 4.0	249	9 x 1.8	690	720	215 x 6	270
250	273.0 x 4.0	310	11 x 2.2	910	920	270 x 6	380
300	323.9 x 5.0	363	11 x 2.2	1160	-	320 x 6	-

*Depending on availability, slightly deviating pipe wall thicknesses may be used

**Long shear spring design with projecting length on request

Weights kg

DN	Structural lengths							
	1.0 m	2.0 m	2.8 m	3.0 m	4.0 m	5.0 m	5.8 m	6.0 m
40	3.5	5.8	7.6	8.2	11	13.4	14.5	15
50	4.4	7.3	9.7	10.3	13.2	16.1	18.5	19.1
65	5.5	9.2	12.3	13.0	16.7	20.4	23.5	24.1
80	8.2	13.8	18.5	19.4	25.1	30.7	35.4	36.4
100	11.1	19.3	27.4	27.4	35.5	43.6	52.5	51.7
125	14.2	24.2	33.6	34.2	44.1	54.1	64.5	64.1
150	18.2	30.7	40.6	43.1	55.6	68.0	77.7	80.5
175	21.2	35.6	47.1	50.0	64.4	78.7	90.2	93.1
200	29.1	50.8	68.1	72.4	94.0	115.6	133.0	137.3
250	44.9	78.6	106.9	112.3	146.0	179.7	207.9	213.3
300	61.3	101	132	140	180	219	250	258

Weight determined on the basis of a calculation.



GWE training – Get in touch with us!

Pump riser pipes stainless steel – Riser pipe PN100

Product description

The PN100 connection from GWE is a riser pipe with a particularly robust design based on established ZSM technology. Designed for high pressure levels, the system achieves its high tensile strength via two link chains instead of conventional shear springs. The flexible, easy to assemble link chains offer a straightforward high-performance system based on proven technology.



Product characteristics

- Pressure rating PN100
- Stainless steel types AISI 304; AISI 316 (other material qualities on request)
- High-performance thread connector with two O-rings and two chain links
- Standard lengths 1 to 6 m
- Direction of installation: Tap downwards and spigot socket upwards

Benefits

- Installation depths up to 1,000 m possible
- Guaranteed tensile strength 100 t
- Pressure rating PN100
- High installation depths
- Easy handling thanks to the use of link chains

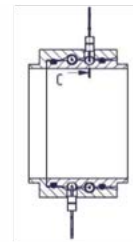
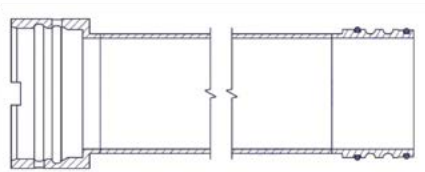

Technical data

DN	ø x wall thickness mm	Outer diameter spigot socket mm	Inner diameter spigot socket mm	Link chain mm		O-ring mm	Flow rate m ³ /h	Tensile strength kN	Weight kg
				d	L				
150	168.3 x 6	210	156	12	632	161.9 x 7	62–187	1,000	11.6
200	219.1 x 6	270	207	12	750	215.0 x 6	111–333	1,000	18.4
250	168.3 x 6	315	263	12	968	268.0 x 6	173–520	1,000	17.6
300	219.1 x 6	368	314	12	1,128.5	316.87 x 7	250–748	1,000	21.7

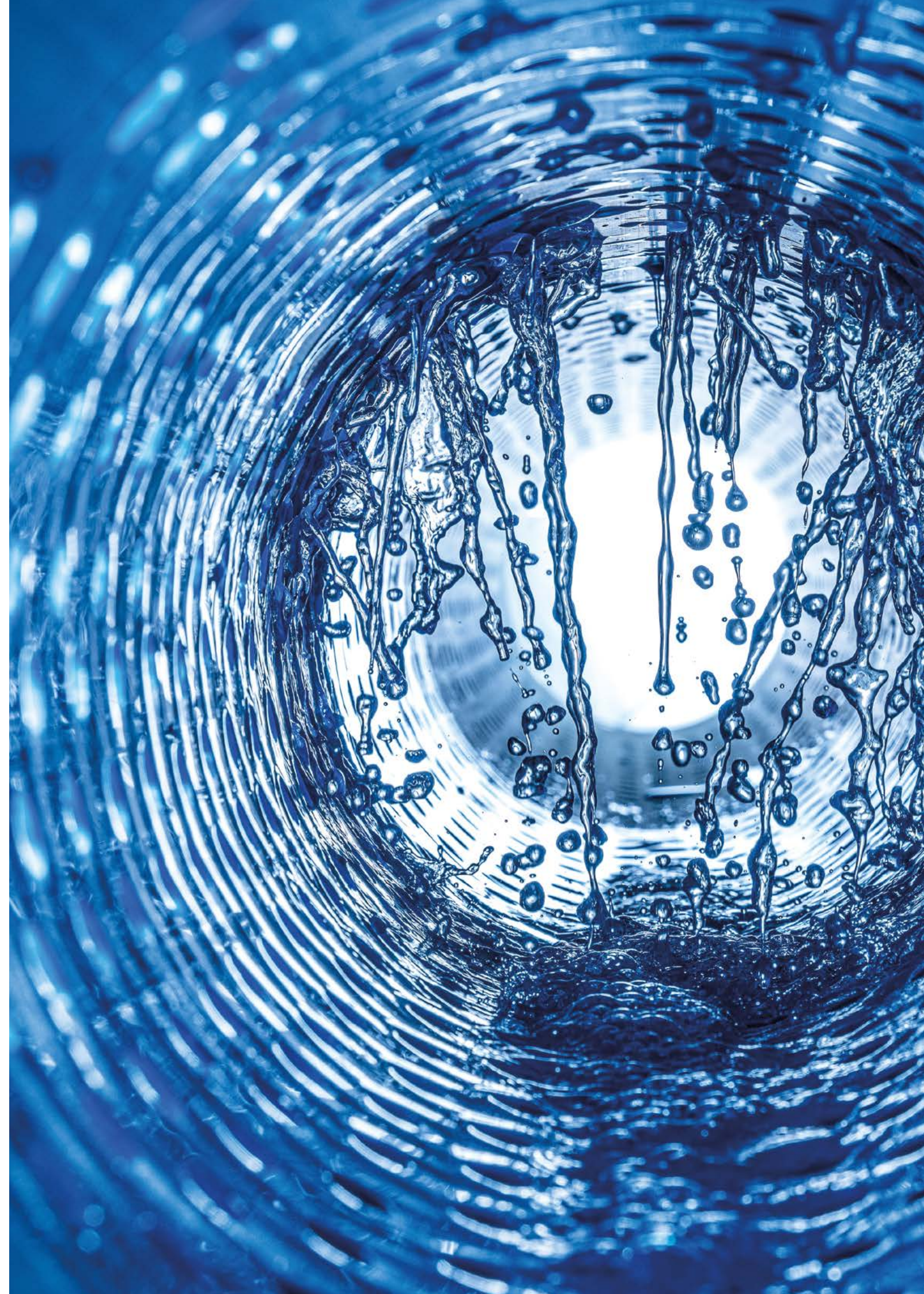

Pump riser pipes plastic – SBF-SECA® riser pipe

Product description

At the temperatures occurring in groundwater extraction wells, the riser pipe is resistant to all types of groundwater, seawater and brine. The material can even resist diluted acids and bases.



Product characteristics

- Material: PVC-U
- Structural length: 0.5/1/2/3/4 m
- Connection type: Trapezoidal thread (spigot socket/tap with safety cap)
- Sealing: NBR
- Pressure rating: PN 10
- Max. installation depth: 100 m (depending on the pump capacity)

Benefits

- Manual screw fitting of trapezoidal thread in a matter of seconds
- One-of-a-kind torsion protection against unintentional unscrewing
- Reliable leak tightness of connection thanks to factory-installed sealing ring
- Extremely slim design enables installation in wells starting from DN 80
- Considerably lower pipe friction losses than comparable steel pipes
- Low weight, maintenance and corrosion-free
- Safe for drinking water and untreated water

Physical material characteristics

Characteristics			Test methods
Elasticity modulus approx.	N/mm ²	2,000–2,500	DIN EN ISO 178
Notch impact strength at 23 °C	kJ/m ²	10–20	DIN EN ISO 179
Density approx.	g/cm ³	1.4	DIN 53479
Yield stress approx.	N/mm ²	45–55	DIN EN ISO 527-2
Impact strength		Max. 10% break	Based on DIN EN ISO 179
Vicat softening temperature approx.	°C	80	DIN EN ISO 306

Models

DN	External Ø pipe mm	Wall thickness mm	External Ø safety cap mm	Adapter pump/riser pipe	Adapter riser pipe/well head
40	48	3.5	76	R 1 1/2"	R 1 1/2"
50	60	5.0	84	R 2"	R 2"
65	75.2	5.6	106	R 2 1/2"	R 2 1/2"
80	90	6.7	125	R 3"	R 3"

Installation of SBF-SECA® riser pipes

1. Screw the conversion adapter (see Fig. 1) into the submersible motor pump.
2. The packaging and protective caps of SBF-SECA® pipes must only be removed directly before installation. Before screwing them in, the thread and sealing surfaces of the pipe and spigot socket must be checked for faultless condition and hygiene. It must be checked that the sealing ring is present. Position the submersible motor pump as vertically as possible next to the well and align the conversion adapter with the first riser pipe!
3. Tighten the first pipe manually suspended on the lifting cap with the conversion adapter. Make sure that the outer grooves of the tap and spigot socket are flush. Push the safety cap over the tap and the spigot socket. Make sure that the safety cap engages under the edge of the spigot socket.
4. Lift the submersible pump with conversion adapter and first SBF-SECA® pipe. Mount the centering units of the submersible pump.
5. The interception of the pipes after lowering can occur below the edge of the spigot socket. To prevent dynamic stress on the pipework, this must be lowered carefully and slowly. Before lowering the pipe and after lifting it, release the retaining clamp and make sure to push the safety cap over the tap and the spigot socket. Make sure that the safety cap engages under the edge of the spigot socket.
6. Connecting the other SBF-SECA® pipes together is carried out in the same way as depicted above.
7. Centering units must be attached to the pipe directly above the submersible pump and then at approx. 8 m. (Observe the installation instructions of the centering units).
8. Fasten the cable of the submersible pump tightly with cable clamps above and below the connection.
9. After installation of the last riser pipe, mount the conversion adapter to the well head (see Fig. 2). Establish the pipe connection as depicted. Installing a backflow inhibitor above the riser pipe is urgently recommend due to potential water shocks.



Fig. 1



Fig. 2

Pump riser pipes with coating – HAGULIT® riser pipe flange

Product description

The HAGULIT® riser pipes with flange combine strong physical properties with outstanding chemical properties. The flange joint in accordance with DIN 4927 with 2 cable passages ensures a high degree of tensile strength and functionality. Defined by the use of corresponding sealing sets, the system enables use even at greater depths.

The pipe clamp made of black steel is extremely robust and can handle high loads. On the other hand, the HAGULIT® coating, certified for drinking water, is characterized by its high chemical resistance. The combination of these two elements results in a product for the most demanding requirements that is highly economically attractive at the same time.



Product characteristics

- Material: Steel S235JR with HAGULIT® coating
- Structural length: 1 to 5 m
- Pressure rating: PN 16
- Connection type: Flange DN 50-DN 250
- Accessories: Sealing set

Benefits

- Reliability
- High installation depths
- Maximum corrosion protection, infiltration-proof coating
- Resistant against black steel components in the immediate vicinity
- HAGULIT® features outstanding impact strength, abrasion resistance and elasticity
- Electrically isolated installation
- Proven long-term resistance against chemicals and water with high chloride concentrations

Chemical resistance –Excerpt–

Medium	Concentration mg/l
Free carbon dioxide (CO ₂)	1,000
Total salt content (without NaCl)	5,000
Sodium (Na ⁺)	20,000
Calcium (Ca ⁺⁺)	1,000
Magnesium (Mg ⁺⁺)	1,000
Potassium (K ⁺)	250
Chloride (Cl ⁻)	200,000
Hydrogen carbonate (HCO ₃)	2,000
Sulphate (SO ₄ ⁻)	2,000

Upper limit of substances listed (mg/l) at a pH value of 5.5 - 8.0 and max. 80 °C

Dimensions

DN	Media pipe* d ₁ x s mm	Outer diameter flange D _A mm	Bolt circle d _k mm	Screws No. x d mm
40	48.3 x 2.3	150	110	4 x M16
50	60.3 x 2.9	165	125	4 x M16
65	76.1 x 2.9	185	145	4 x M16
80	88.9 x 2.9	200	160	8 x M16
100	114.3 x 3.2	220	180	8 x M16
125	139.7 x 3.6	250	210	8 x M16
150	168.3 x 4	285	240	8 x M16
200	219.1 x 4.5	340	295	8 x M20
250	273.0 x 5	405	355	12 x M20

*Depending on availability, slightly deviating pipe wall thicknesses may be used

Weight kg

DN	1.0 m	2.0 m	3.0 m	4.0 m	5.0 m
40	6.4	9.1	11.7	14.4	17.1
50	8.7	12.3	15.9	19.5	23.2
65	10.7	15.3	20.0	24.6	29.2
80	13.9	20.3	26.8	33.2	39.7
100	18.1	27.0	35.9	44.8	53.7
125	24.9	37.1	49.4	61.7	74.0
150	31.9	48.3	64.7	81.1	97.5
200	48.8	75.6	102.4	129.2	156.0
250	64.7	98.2	131.7	165.2	198.7

Weight determined on the basis of a calculation.

Pump riser pipes with coating – HAGUDOSTA® riser pipe ZSM, PN16

Product description

The HAGUDOSTA® riser pipes combine strong physical properties with outstanding chemical properties and a sophisticated installation system. Defined by the use of **two O-rings and two shear rods** as a connecting element, the socket joint with high tensile strength in accordance with the GWE company standard is optimally suited for quick installation.

The pipe clamp made of black steel is extremely robust and can handle high loads. On the other hand, the HAGULIT® coating, certified for drinking water, is characterized by its high chemical resistance. The combination of these two elements results in a product for the most demanding requirements that is highly economically attractive at the same time.



Product characteristics

- Material: Steel S235JR with HAGULIT® coating
- Structural length: 1 to 5 m
- Connection type: ZSM DN 0 to DN 250
- Accessories: 2 O-rings and 2 POM* shear rods
- Pressure rating: PN 16
- Installation direction with spigot socket upwards and tap downwards

Benefits

- Quick installation
- Slim connection
- Maximum corrosion protection, infiltration-proof coating
- Resistant against black steel components in the immediate vicinity
- HAGULIT® features outstanding impact strength, abrasion resistance and elasticity
- Electrically isolated installation
- Proven long-term resistance against chemicals and water with high chloride concentrations

Chemical resistance –Excerpt–

Medium	Concentration mg/l
Free carbon dioxide (CO ₂)	1,000
Total salt content (without NaCl)	5,000
Sodium (Na ⁺)	20,000
Calcium (Ca ⁺⁺)	1,000
Magnesium (Mg ⁺⁺)	1,000
Potassium (K ⁺)	250
Chloride (Cl ⁻)	200,000
Hydrogen carbonate (HCO ₃)	2,000
Sulphate (SO ₄ ⁻⁻)	2,000

Upper limit of substances listed (mg/l) at a pH value of 5.5–8.0 and max. 80 °C

Technical parameters

DN	Media pipe* d ₁ x s mm	Outer diameter spigot socket D mm	Shear rod D _s x L mm	O-ring D _o x d _o mm	Tensile strength kN
50	60.3 x 2.3	82	5 x 300	59 x 5	35
65	76.1 x 2.6	101	5 x 350	75 x 5	45
80	88.9 x 2.9	114	6 x 450	86 x 6	60
100	114.3 x 3.2	140	6 x 520	112 x 6	80
125	139.7 x 3.6	169	6 x 600	135 x 6	100
150	168.3 x 4.0	201	8 x 710	166 x 6	150
200	219.1 x 4.5	253	8 x 860	212 x 6	200
250	273.0 x 5.0	308	8 x 970	270 x 6	250

*Depending on availability, slightly deviating pipe wall thicknesses may be used

Pump riser pipes with coating – HAGULIT® hybrid riser pipe ZSM, PN25

Product description

The HAGULIT® hybrid riser pipes combine the commercial benefits of coated black steel pipes with the strong physical characteristics of the tension-resistant push-fit sleeve connection ZSM PN25 WN from GWE. The connections are made of stainless steel and enable increased load-bearing capacity as well as a higher pressure rating. The stainless steel quality can be tailored to suit the requirements.



Product characteristics

- Material: Steel pipe S235JR with HAGULIT® coating
- Connection: Stainless steel 1.4301 or 1.4571/1.4404, additional material qualities on request
- Structural length: 1 to 5 m
- Connection type: ZSM DN 50-DN 200
- Pressure rating: PN 25

Benefits

- Increased load-bearing capacity
- Slim connection
- Economic efficiency

Dimensions

DN	Media pipe* d _R x s mm	Outer diameter spigot socket D _M mm	Shear spring mm			O-ring D _O x d _O mm	Tensile strength σ _Z kN
			d _S x s	L ₁	L ₂ **		
50	60.3 x 2.3	87	7 x 1.50	205	215	60 x 5	50
65	76.1 x 2.6	104	7 x 1.50	265	275	77 x 5	65
80	88.9 x 2.9	117	7 x 1.50	280	310	88 x 5	80
100	114.3 x 3.2	141	7 x 1.50	350	385	110 x 5	100
125	139.7 x 3.6	168	7 x 1.50	445	470	136 x 5	125
150	168.3 x 4.0	200	9 x 1.80	535	560	166 x 6	150
200	219.1 x 4.5	251	9 x 1.80	690	720	215 x 6	200

*Depending on availability, slightly deviating pipe wall thicknesses may be used

**Long shear spring design with projecting length on request

Weight kg

DN	1.0 m	2.0 m	3.0 m	4.0 m	5.0 m
50	6.4	10.7	15.0	19.3	23.6
65	7.8	13.3	18.8	24.3	29.8
80	9.9	16.3	22.8	29.2	35.7
100	12.5	21.4	30.3	39.2	48.1
125	16.0	28.3	40.6	52.8	65.1
150	22.2	38.6	55.0	71.4	87.8
175	26.9	45.9	64.9	83.9	102.9
200	36.3	63.1	89.9	116.7	143.5

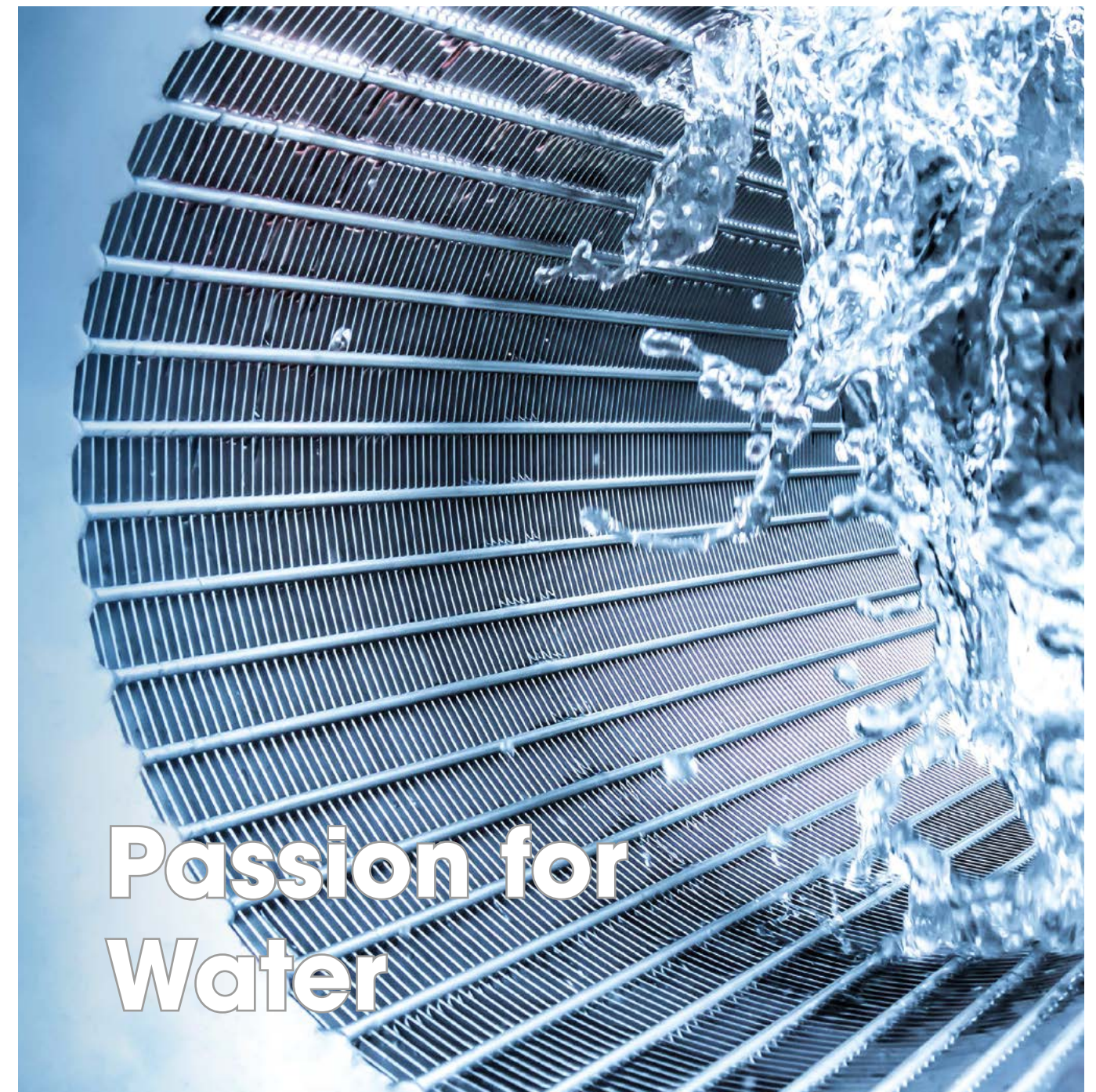

Pump riser pipes with coating – HAGULIT® hybrid riser pipe ZSM PN 40

Product description

The HAGULIT® hybrid riser pipes combine the commercial benefits of coated black steel pipes with the strong physical characteristics of the tension-resistant push-fit sleeve connection ZSM PN40 from GWE. The connections are made of stainless steel and enable increased load-bearing capacity as well as a higher pressure rating. The stainless steel quality can be tailored to suit the requirements.



Product characteristics

- Material: Steel pipe S235JR with HAGULIT® coating
- Connection: Stainless steel 1.4301 or 1.4571/1.4404, additional material qualities on request
- Structural length: 1 to 5 m
- Connection type: ZSM DN 50 to DN 200
- Pressure rating: PN 40

Benefits

- Greatly increased load-bearing capacity
- Slim connection
- Economic efficiency

Technical parameters

DN	Media pipe* d _R x s mm	Outer diameter spigot socket D _M mm	Shear spring mm			O-ring D _O x d _O mm	Tensile strength σ _Z kN
			d _S x s	L ₁	L ₂ **		
50	60.3 x 2.3	87	7 x 1.50	205	215	60 x 5	50
65	76.1 x 2.6	104	7 x 1.50	265	275	77 x 5	65
80	88.9 x 2.9	117	7 x 1.50	280	310	88 x 5	80
100	114.3 x 3.2	141	7 x 1.50	350	385	110 x 5	100
125	139.7 x 3.6	168	7 x 1.50	445	470	136 x 5	125
150	168.3 x 4.0	200	9 x 1.80	535	560	166 x 6	150
200	219.1 x 4.5	251	9 x 1.80	690	720	215 x 6	200

*Depending on availability, slightly deviating pipe wall thicknesses may be used

**Long shear spring design with projecting length on request

Weight kg

DN	1.0 m	2.0 m	3.0 m	4.0 m	5.0 m
50	6.4	10.7	15.0	19.3	23.6
65	7.8	13.3	18.8	24.3	29.8
80	9.9	16.3	22.8	29.2	35.7
100	12.5	21.4	30.3	39.2	48.1
125	16.0	28.3	40.6	52.8	65.1
150	22.2	38.6	55.0	71.4	87.8
175	26.9	45.9	64.9	83.9	102.9
200	36.3	63.1	89.9	116.7	143.5

Pump riser pipes with coating – HAGUTHERM® riser pipe

Product description

The HAGUTHERM® riser pipes feature strong physical properties and outstanding chemical resistance. The inner and outer hard rubber lining is applied through a vulcanization treatment and therefore features high thermal and chemical resistance. The pipes are particularly suited for medium-depth geothermal applications, for example to transport water with high chloride concentrations from depths of up to 400 meters.



Product characteristics

- Base material: S235JR steel
- Coating: Hard rubber lining HAGUTHERM® H1109
- Structural length: 1 to 6 m
- Connection type: Chambered sharp V thread with O-ring sealing
- Accessories: 2 x O-rings
- Pressure rating: Up to PN 40

Benefits

- Installation possible up to 400 m
- Maximum corrosion protection, infiltration-proof coating
- Proven long-term resistance against water with high chloride concentrations
- Temperature resistance in continuous operation up to 80 °C
- Easy, repeatable installation and dismantling

Dimensions

DN	Media pipe* d ₁ x s mm	Outer diameter spigot socket D _A mm	O-rings D _O x s mm	Weight** when L = 6 m m _G kg
125	139.7 x 4.5	159	135 x 6	103
150	159.0 x 5.0	178	166 x 6	140
175	193.7 x 5.6	214	187 x 7	176
200	219.1 x 6.3	241	215 x 7	218

*Depending on availability, slightly deviating pipe wall diameters may be used

**Weight determined on the basis of a calculation

Storage

For longer periods of storage outdoors, the pipes must be protected against direct sunlight and temperatures below freezing. It is recommended not to install, transport or move the pipes at temperatures below freezing (0 °C and below).



4. Fiberglass

Fiberglass – Fiberglass-reinforced plastic pipes (FRP)

As an optimal supplement and extension of the product portfolio, GWE also offers fiberglass-reinforced high-pressure pipes and fittings for a wide range of applications.

FRP (known as fiberglass) is a fiber-plastic composite consisting of a plastic (e.g. unsaturated polyester, vinyl ester or epoxy resin) and glass fibers, as well as reaction resins depending on the type of the plastic used and the manufacturing method. It combines the extremely high tear resistance of glass fibers with the corrosion resistance and media resistance of resin. FRP is not a homogeneous material, as it comprises various layers of glass fibers and resins. For this reason, the elasticity modulus values are different in the axial and radial directions. Based on the orientation of the reinforcement fibers, the permissible elongation also differs, as well as the proportional elasticity limits in both directions. The selection of the resin/hardening agent has an influence on the chemical resistance and temperature behavior of the composite matrix, while the choice of the glass type determines the mechanical characteristics such as tensile strength, pressure resistance and elasticity modulus.

Fiberglass in comparison

It is interesting to compare FRP and its specific characteristics with materials that can be used in the same or similar applications, such as steel or high-density polyethylene (HDPE). In principle of course, each application has to be

considered individually with the specific parameters and conditions, and a material may possibly be excluded a priori if certain thresholds are exceeded, yet FRP features impressive characteristics in nearly all components. When it comes to the material purchasing price, it is important to consider more than just the pure investment costs. Apart from its technical characteristics, the overall cost over the course of its useful life is what makes FRP the “first choice” for products even from a commercial perspective.

Fiberglass – field line pipes

Field line pipes for oil and gas extraction are manufactured in the dimension range from 1-1/2” to 8” (DN 40 – DN 200 mm) and, depending on the pipe design, are resistant to pressures up to 4,000 psi (275 bar) and temperatures up to 200° F (93.3 °C). These products are also used for transporting highly corrosive media from collection stations on oil fields to the injection wells. These pipes are also used for discharge lines that hold corrosive fluids.

Fiberglass – Down hole tubing and casings with threaded connection

Particularly in the area of vertical applications, our products lead their category. Due to the unique 0° und 70° wrap angle technology used for manufacture, the products offer optimal tensile strengths and transfer of forces.



Down hole tubing is produced in the dimension range from 1-1/2” to 4-1/2” (DN 40–DN 100 mm) with compressive strengths of 1,000 to 4,000 psi (69–275 bar). Down hole casings range from 5-1/2” to 9-5/8” (DN 125–DN 200 mm) with compressive strengths of 1,000 to 2,500 psi (69–172 bar).

Down hole products can also be produced with three different hardening systems, which means a temperature resistance of max. 200° F (104 °C). All products are delivered in nominal standard lengths of 30 ft. (~9 meters). The tubing and casings are principally used for saltwater injection wells, in which the injection fluids are corrosive, for observation wells where the resulting formations need to be inspected and steel could interact with the equipment, as well as for production wells in which steel pipes are at risk of slight corrosion. The FRP pipes are designed for use at depths of up to ~3,000 m in a highly corrosive environment. In conjunction with our stainless steel wire-wrapped screens, the pipes are also suitable for use in brine wells, for example, as a construction material or riser pipe.

Manufacturing method

Manufacture is carried out using the filament winding method with the main components epoxy resin and three different hardening systems: aromatic amines, aliphatic amines or anhydrides.

Every resin/hardening agent combination has specific characteristics, for instance resistance to chemicals, mechanical functions and also temperature and pressure resistance, which make one pipe system more suitable than another for particular applications.

In the filament winding method, continuous filament strings (rovings) are passed through a resin bath and thus moistened

with the matrix material and then laid tightly and close together on a radially rotating spindle. This is followed by thermal hardening using the three possible reaction resins.

This manufacturing method enables the production of pipes in various layers with potential winding angles of 55°, or 0° + 70° (dual winding). This two-angle method is used for manufacturing products for vertical applications. The 70° layers ensure the internal and external compressive strength of the string and thus prevent potential pipe collapse. The 0° layers prevent excessive elongation and thus a deformation of the pipes, and ensure resistance against axial stresses through the net weight of the string and the resulting tensile forces. Due to the fact that FRP pipes behave differently depending on the direction, this winding geometry enhances and improves the strength many times over without requiring an increased use of materials.

Fiberglass – Down hole tubing and casings with ZSM connection

The connection comprises a tap with two O-rings and a spigot socket, a shear spring and as needed an additional rotation lock (riser pipe). The spigot socket is shaped at one side of the pipe, the tap comprises the other end. The hydraulic sealing is ensured by the two O-rings made of rubber. The mechanical coupling is carried out through a locking mechanism that is introduced through the spigot socket into a groove. This connection is very easy to set up and can reduce the installation time by up to 50%. To prevent rotation of the pipe string during installation and operation, the connection can also be manufactured with a special rotation lock. The pipes are designed and manufactured based on the specific application.

Riser pipes are available in DN 50, 80, 100, 150 and 200. Casings from DN 50 to DN 1,200.







5. Submersible pumps

Product overview	104
Specialist knowledge	106
GWE is SUB FACTORY for Grundfos	108
GWE 4"-12" submersible pumps	110
GWE 4" submersible pump with geothermal range motor	116
GWE high-efficiency submersible pump system	117
GWE sampling system MP 1	118
Centrifugal pumps	119
ROBU submersible motor pumps	120
HONDA used water and wastewater pumps	139
GWE Monitoring & Control System (MCS)	144
Accessories	146



Access current information about the product area online

Submersible pumps

	MP1	SQ/SQE	GWE GEO	SP	GWE	GWE High-Efficiency	SPNE
Product							
Product type	Q max. 2.5 m³/h H max. 90 m P2 up to 1.1 kW Well Ø 2"	Q max. 9 m³/h H max. 200 m P2 up to 1.85 kW Well Ø from 3"	Q max. 18 m³/h H max. 50 m P2 up to 3 kW Well Ø from 4.5"	Q max. 280 m³/h H max. 670 m P2 up to 220 kW Well Ø from 4.5"	Q max. 520 m³/h H max. 950 m P2 up to 350 kW Well Ø from 4.5"	Q max. 450 m³/h H max. 540 m P2 up to 250 kW Well Ø from 4.5"	Q max. 21 m³/h H max. 210 m P2 up to 7.5 kW Well Ø from 4.5"
Application	<ul style="list-style-type: none"> • Water sampling in groundwater measurement points of 2" 	<ul style="list-style-type: none"> • Water sampling • Home water supply • Garden irrigation 	<ul style="list-style-type: none"> • Geothermal energy • Water-water heat pump 	<ul style="list-style-type: none"> • Municipal water supply • Industry • Agriculture • Water-water heat pump 	<ul style="list-style-type: none"> • Municipal water supply • Industry • Agriculture • Fire extinguishing systems • Dewatering systems • Garden irrigation 	<ul style="list-style-type: none"> • Municipal water supply • Industry • Agriculture 	<ul style="list-style-type: none"> • Contaminated sites in landfills and industrial production processes
Product benefits	<ul style="list-style-type: none"> • Diameter (45 mm) • Low weight 	<ul style="list-style-type: none"> • Diameter (74 mm) • Alternating current 1 x 230 V 50 Hz 	<ul style="list-style-type: none"> • Finely graduated pump head range from 9 m • Efficiency 	<ul style="list-style-type: none"> • Stainless steel qualities (AISI 304, 316 and 904L) 	<ul style="list-style-type: none"> • Custom design up to 90 °C • Stainless steel qualities (AISI 304, 316 and Duplex) • High-efficiency systems available 	<ul style="list-style-type: none"> • Reduced motor heating • Up to 20% energy savings in some instances • Reduced cable diameter 	<ul style="list-style-type: none"> • Chemical resistance • Stainless steel qualities (AISI 316 and 904L) • Viton

Motor technology of the submersible motor pumps

Submersible motor pumps

Our product portfolio includes GWE pumps from our in-house production as well as Grundfos brand submersible pumps. More details can be found in the following overviews or the special catalogs that are mentioned.

Motor technology

A submersible pump is operated using a submersible motor. These motors can be filled with either oil or water, although in Germany solely water-filled motors may be used when pumping water from wells. The submersible motors are generally made of stainless steel. Both asynchronous and synchronous motors are used to operate the pumps.

Asynchronous motors

The name “asynchronous motor” came about because the rotor of the motor turns out of sync with the magnetic field on the stator. This effect is explained by the fact that the motor always requires a corresponding torque in order to turn. If the rotor were to turn at the same speed as the stator’s rotary field, no torque would be generated and the rotor would remain immobile. However, because the rotor rotates at a slower speed, there is always torque in play. This difference in rotational speeds is also referred to as “slip”.

Asynchronous motors are very simple in their construction and thus also highly cost-effective to procure. They can be operated directly from the power grid with a frequency converter.

During grid operation, asynchronous motors can exclusively be operated at the nominal speed. The advantage of a frequency converter is that the motor’s speed can be controlled. Thanks to this speed control, the power of the motor and pump can be configured to suit the customer’s needs. If the motor’s power is reduced, this also decreases the electrical energy consumption and thus the energy costs as well.

Synchronous motors

In contrast to the asynchronous motors described above, the rotor of a synchronous motor turns “in sync” with the rotary field of the stator. This can be explained by the fact that permanent magnets are used on the inside of the motor which always generate torque regardless of the speed.

Synchronous motors are more expensive to construct and procure due to the use of permanent magnets, since the permanent magnets are manufactured using rare earth metals (e.g. samarium, neodymium, praseodymium, terbium and dysprosium), which are very cost-intensive. In addition, synchronous motors can only be used together with a frequency converter.

Advantages and disadvantages

One major disadvantage of asynchronous motors is that they have a low power factor (between 0.7 and 0.9). In order to function, synchronous motors require something known as reactive power, which fluctuates back and forth along the lines between the grid operator and the pump operator. This power cannot be used by the engine. However, because reactive power places a burden on the power lines, the pump operator has to pay the grid operator for the reactive power in addition to the required active power.

In contrast, synchronous motors have a very high power factor (approximately 0.99). As a result, the pump operator only has to pay the network operator for the active power. In addition to their higher power factor, synchronous motors are also more efficient.

Overall, synchronous motors can save up to 20% in energy costs compared to asynchronous motors. The time it takes for this to pay off can be calculated based on the motor capacity and the annual operating hours of the pump.

Assembly and repairs

The pumps are fully assembled at GWE and can be equipped with a submersible cable suitable for drinking water as needed. After completion, the pumps are tested on our pump test stand and sent to the customer with the corresponding test certificate.

Furthermore, we offer a repair service for pumps from all brands.



GWE is SUB FACTORY for Grundfos

For many years now, GWE has collaborated with renowned pump manufacturers as a trusted partner. We maintain a special business relationship with Grundfos.

GWE is exclusively authorized in Germany as a GRUNDFOS SUB FACTORY. This means fast delivery service for submersible pumps that are subject to ISO-certified assembly and tested with certification on the GWE test stand before dispatch.



GWE is exclusively authorized in Germany as a GRUNDFOS SUB FACTORY!



What does this mean for you?

The benefits for you:

- Fast delivery service from GRUNDFOS submersible pumps. We keep components from series SP 17 to SP 215 in stock. Using these components, assembly units for specific orders are put together and delivered.

- GWE offers ISO-certified assembly of GRUNDFOS submersible water pumps. The same level of quality as for direct purchase from GRUNDFOS.
- “Just in time” delivery of pumps with cables and accessories (e.g. riser pipes, joints, control panels, well heads, pressure tanks etc.)

Submersible pumps can be delivered immediately for the following capacity ranges:

Nominal yield	Pump head
17 m ³ /h	15–160 m
30 m ³ /h	15–170 m
46 m ³ /h	10–170 m
60 m ³ /h	10–160 m
77 m ³ /h	18–280 m
95 m ³ /h	10–250 m
125 m ³ /h	15–380 m
160 m ³ /h	13–300 m
215 m ³ /h	12–260 m

Submersible motor pumps and submersible motors are also available immediately in larger quantities as well.

Type	Nominal yield	Pump head
3" SQ – Submersible pumps	1–7 m ³ /h	20–180 m
4" submersible pumps	1–18 m ³ /h	8–200 m
6" and 7" submersible pumps	20–90 m ³ /h	20–150 m
8" and 10" submersible pumps	25–240 m ³ /h	20–170 m
4", 6" and 8" submersible motors up to 110 kW		

We would be happy to provide you with extensive advice for your water well construction project in order to ensure reliable and efficient irrigation.



GWE 4"-12" submersible pumps

Product description

GWI pumps and motors are constructed from stainless steel AISI 304 and are optimally suited for use in drinking water wells. The pumps are operated with asynchronous motors, but can also be equipped with highly efficient permanently excited synchronous motors. We offer ready-to-use complete systems with suitable frequency converters. Thanks to the blue cable certified for use with drinking water, our pumps can be used in many areas.

Benefits

Apart from their good value for money and high pump efficiency, another advantage of GWE pumps is their rapid availability. Our well-stocked components warehouse with adjacent installation and service area enables short delivery times. Thanks to our highly modern pump test stands, the condition and performance of the pumps is inspected, documented and guaranteed. Above and beyond the presented product portfolio, we offer custom pump systems for all applications.

Compressive strength development

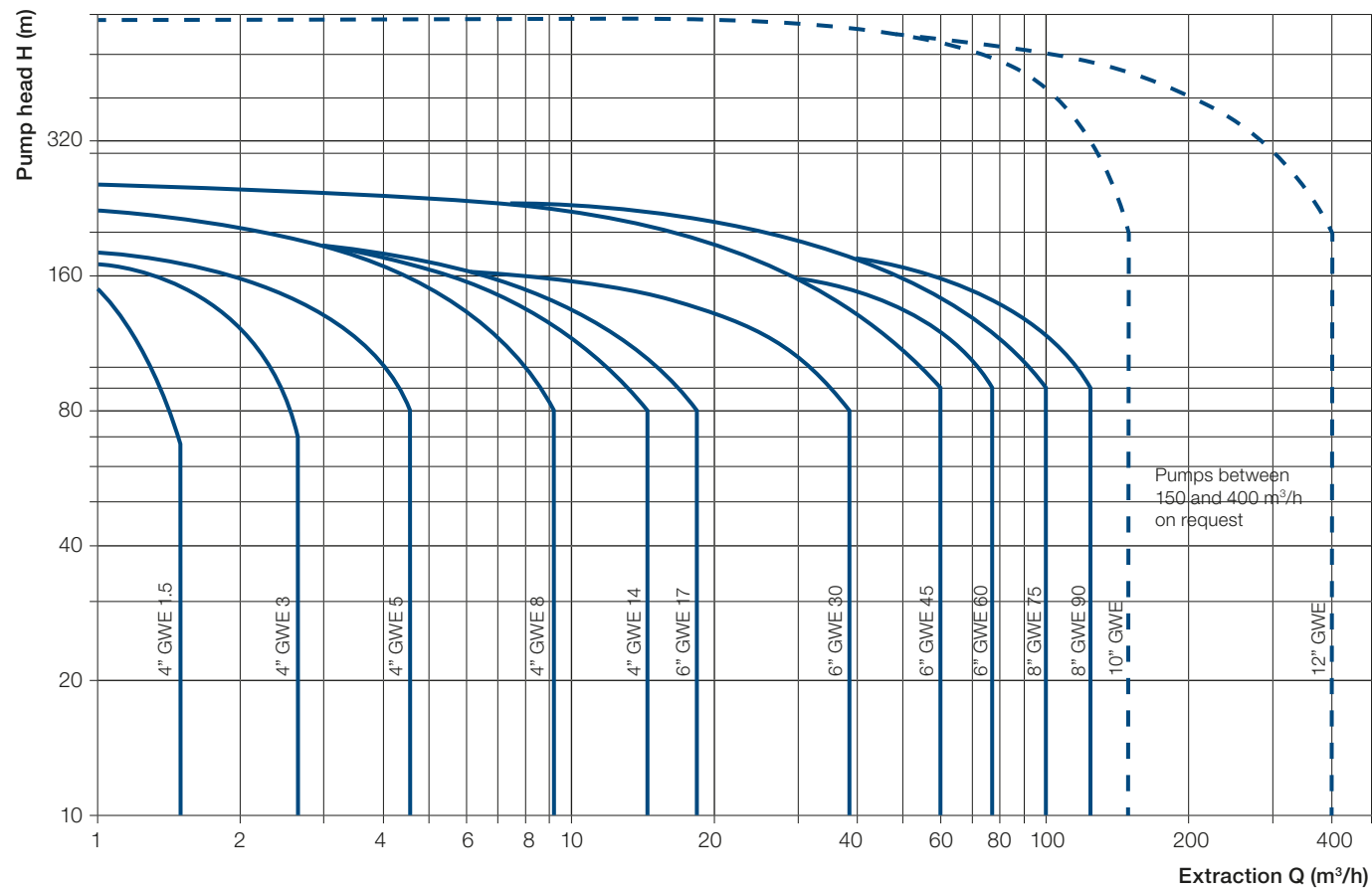

Model code

4" GWE submersible pumps

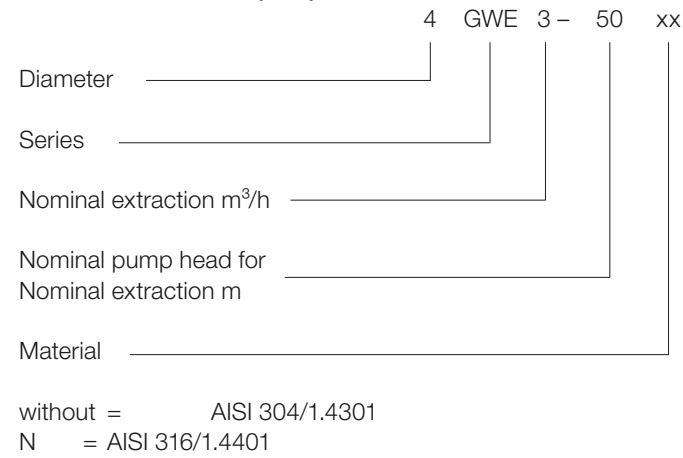

6" to 12" GWE submersible pumps

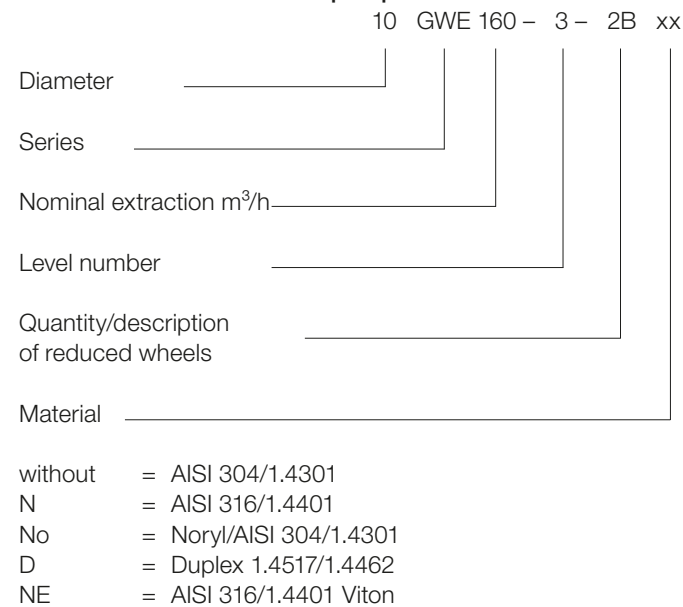

Conveying media

For the conveyance of drinking water and untreated water without abrasive or long-fibered components. (sand content max. 50 g/m³). The conveying medium must not chemically attack the pump materials.

Characteristic curves, characteristic curve conditions

For the characteristic curves below, the following general conditions apply:

- Tolerances pursuant to ISO 9906, Annex A
- The characteristic curves apply for submersible motors with nominal speeds: n = 2,900 min⁻¹
- The characteristic curves are determined at a water temperature of 20°C with de-aerated water. The characteristic curves apply for a kinematic viscosity of $\nu = 1 \text{ mm}^2/\text{s}$. If fluids with a higher viscosity need to be conveyed, motors with correspondingly higher capacities must be used.

- **Q/H:** The characteristic curves already include valve and in-feed losses in the current speed.
- For operation without a check valve, the pump head is elevated at the nominal extraction by approx. 0.5 m to 1.0 m.
- **Power curve:** P₂ shows the pump's power need per level at the nominal speed.
- **Efficiency curve:** η shows the efficiency of a single pump level at the nominal speed. The efficiency for low-level pumps is somewhat lower than portrayed and can be calculated as follows.

Energy consumption of submersible motor pumps

The percentage distribution of the total costs for operating submersible pumps in water supply systems is as follows:
ca. 5% acquisition costs (pump)
ca. 85% operating costs / energy costs
ca. 10% maintenance costs
It is apparent that the greatest savings are possible when it comes to energy costs.

For water supply systems, the submersible pumps are frequently larger than necessary and are thus inefficient in operation. By switching to a pump optimally designed to the system, energy costs are reduced and the service life of the pump is extended.

The annual energy consumption E of a submersible pump can be calculated as follows:

$$E = c \times h \times P_1 = (\text{€})$$

with:
c = specific energy price (ca. 0.2 €/kWh)
h = Operating hours per year
P₁ = Power consumption of the submersible pump kW

Calculation of pump efficiency

To calculate the current efficiency of a pump with a standard motor, the following formula is used:

$$\eta_p = \frac{Q \times H}{P_2 \times 367} \times 100$$

with:
Q = Extraction in j³/h at operating point
H = Pump head in m at operating point for the pump
 η_p = Calculated pump efficiency at operating point
P₂ = Power demand in kW at operating point from the characteristic curve

NPSH values

Up to an NPSH value of 10 m and an intake height (water level) of 1 m above the infeed section, no cavitation occurs with cold water and air pressure at sea level (approx. 10 m).

For the series 4 GWE, 6 GWE and 8 GWE, the NPSH value is below max. 8 m. Please note the required covering for series 10 GWE 160 to 12 GWE 450.

For NPSH values > 10 m, the required intake height is determined according to the following formula:

$$H_s = H_B - H_D - \text{NPSH} - S$$

with:

- H_s = Required intake height
Positive value:
Pump could work in suction mode
Negative value:
Pump requires the H_s value as intake
- H_B = Air pressure height
Installation at sea level
(for practical application = 10 m)
- H_D = Steam pressure height
(for cold water, $H_D = 0$ can be set),
otherwise from steam pressure table
- NPSH = Net Positive Suction Head
- S = Safety addition (1 m recommended)

For water supply systems/drainage systems, the yield is based on the connected consumers or productivity of the well.

The pump head for drainage systems or water supply systems is derived from:

$$H_{\text{total}} = H_{\text{geo}} + H_f + P_{\text{tap}} \times 10.2$$

with:

- H_{geo} = Height difference between consumer and lowered water level.
- H_f = Pressure loss in the pipelines and fittings downstream of the submersible pump
- P_{tap} = Required pressure at the consumer in bar

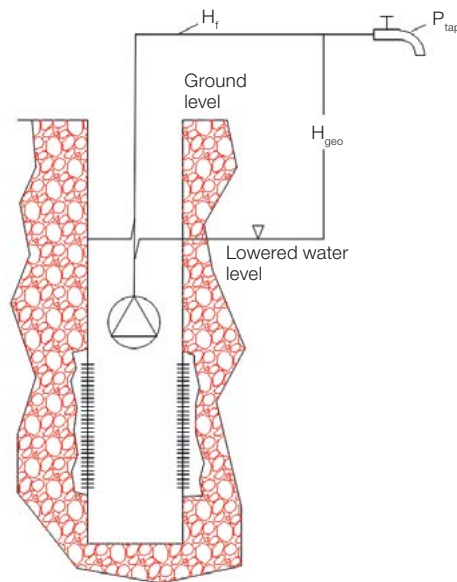

Operating data

Motor	Installation			
	Max. operational pressure	Flow at the motor	Vertical	Horizontal
MS 4" and 6" MS 402	60 bar 15 bar	0.15 m/s	30 °C	
GWE/FE 4"	35 bar	0.15 m/s	30 °C	
FE 6" + 8" encapsulated/rewindable	35 bar	0.2 m/s	30 °C	Up to 11 kW
FE 8" rewindable from 55 kW	25 bar	0.5 m/s	30 °C	
6" GWE	25 bar	0.5 m/s	30 °C	Tilt 15°
8" GWE	25 bar	1 m/s	30 °C	Tilt 15°
10" FE WW	35 bar	0.5 m/s	25 °C	Up to 150 kW
12" FE WW	35 bar	0.5 m/s	30 °C	On consultation

For higher media temperatures, please consult.

Flow at the motor

For installation of a 4" submersible pump in an extraction well with a 6" (150 mm) internal diameter, a cooling sleeve is required on the pump at a volumetric flow of less than 6 m³/h.

Motor cooling

Calculation of current velocity:

$$V = \frac{Q_{\text{min}}}{2,826 \times (D^2 - d^2)} = \text{m/s}$$

- Prerequisite: Extraction Q_{min} (m³/h)
- Diameter of the well D (m)
- Diameter of the motor d (m)

Always install the pump above the well screen!

Motor data

Motor winding	1 x 230 V up to 1.1 kW 3 x 230 V up to 0.37 kW up to 30 kW 3 x 400 V direct 0.37 kW up to 400 kW 3 x 400 V Y/Δ direct 4.0 kW up to 400 kW 3 x 500 V direct 0.37 kW up to 400 kW 1,000 V 50 Hz 85 up to 400 kW
Frequency	50 Hz
Protection class	IP 68
Voltage fluctuation	-10% / +6%
Installation options	For horizontal installation, please consult!

Switch-on frequency

GWE / FE 4" / 6" / 8"	Min. 1x / hour is recommended Max. 20x / hour Max. 200x / day
MS 4" MS 6" 4" + 6"	
6" FE rewindable	Min. 1x / hour is recommended Max. 10x / hour
8" FE rewindable	Min. 1x / hour is recommended Max. 7x / hour
10" FE rewindable	Min. 1x / hour is recommended Max. 10x / hour
12" FE rewindable	Min. 1x / hour is recommended Max. 5x / hour

Range of operation

Type	Q_{min}	Q_{nom}	Q_{max}
	m³/h		
4 GWE 1.5	0.3	1.5	2
4 GWE 3	0.6	3	4
4 GWE 5	1	5	6
4 GWE 8	3	8	11
4 GWE 14	4	14	18
6 GWE 17	3	17	22
6 GWE 20	3	20	27
6 GWE 30	4	30	37
6 GWE 33	5	33	45
6 GWE 45	5	45	60
6 GWE 47	6	47	60
6 GWE 60	6	60	75
6 GWE 63	7	63	80
8 GWE 75	10	75	100
8 GWE 78	12	78	100
8 GWE 90	12	90	120
8 GWE 97	15	97	120
10 GWE 120	20	120	150
10 GWE 150	30	150	180
10 GWE 160	40	160	200
10 GWE 210	60	210	300
10 GWE 300	80	300	360
12 GWE 360	120	360	400
12 GWE 450	150	450	520

Materials table

Description	4 GWE 6 GWE 17/30/45/60	6 GWE 20/33/47/63		8 GWE 78/97	
		Standard 1.4301	New design 1.4401	Standard 1.4301	New design 1.4401
Valve housing	1.4301/AISI 304	1.4301	1.4401	1.4301	1.4401
Valve plate	1.4301/AISI 304	1.4401	1.4401	1.4401	1.4401
Intermediate chamber	1.4301/AISI 304	1.4301	1.4401	1.4401	1.4401
Guide apparatus	1.4301/AISI 304	1.4301	1.4401	1.4401	1.4401
Wheel	1.4301/AISI 304	1.4301	1.4401	1.4401	1.4401
Shaft	1.4057/AISI303	1.4057	1.4460	1.4460	1.4460
Bearing	NBR	NBR	NBR	NBR	NBR
Infeed part	1.4301/AISI 304	1.4301	1.4401	1.4301	1.4401
Sieve	1.4301/AISI 304	1.4801	1.4401	1.4401	1.4401
Tensioning belts	1.4301/AISI 304	-	-	-	-
Cable guard rail	1.4301/AISI 304	1.4401	AISI 316	1.4401	1.4401

Description	8 GWE 75/90 10 GWE 120/150	10 GWE 160 to 12 GWE 450	
		Standard	Duplex
Valve housing	1.4308/AISI 304	1.4308/AISI 304	1.4517/AISI316
Valve plate	1.4308/AISI 304	1.4308/AISI 304	1.4517/AISI316
Intermediate chamber	1.4308/AISI 304	1.4308/AISI 304	1.4517/AISI316
Guide apparatus	1.4308/AISI 304	1.4308/AISI 391	1.4517/AISI316
Wheel	1.4308/AISI 304	1.4308/AISI 304	1.4517/AISI316
Shaft	1.4308/AISI 4087	1.4057 AISI	1.4462
Bearing	NBR	NBR/EPDM	NBR/EPDM
Infeed part	1.4308/AISI 304	1.4308 AISI	1.4517/AISI 316
Sieve	1.4301/AISI 304	1.4571 AISI	1.4539/AISI 904L
Tensioning belts	1.4301/AISI 304	1.4301 AISI	1.4539/AISI 904L
Cable guard rail	1.4301/AISI 304	1.4301 AISI	1.4462/1.4539 AISI 904L

Frequency converter operation

All submersible pumps in series 4 GWE to 12 GWE can be operated with a frequency converter in principle. However, the following must be noted:

- The minimum frequency is 30 Hz. The maximum frequency is 50 Hz.
- The engine performance must be noted.
- For rewindable submersible motors, a PE2/PA winding is recommended. The PE2/PA winding has a maximum temperature resistance of 90 °C, voltage resistance of 1000 V (corresponds to insulation material class Y) and two-layer insulation for enhanced mechanical protection.
- Depending on the operating point (motor load), the motor must always have a power reserve (recommended: 10%).
- Sufficient cooling must be guaranteed with minimal volumetric flow
- Protect motors against impermissibly high voltage peaks
- Voltage/frequency proportional control (U/f = constant)
- Determine the converter according to the nominal current and performance capacity of the selected submersible motor
- Apply L/C screens and RFI screens
- For horizontal installation, please consult

More information can be found in our leaflet regarding frequency converter operation of submersible pumps.

On request, frequency converter switch systems up to 150 kW.

Note: Please note our high-efficiency submersible pump systems with frequency modulation control

Installation instructions:

- Read the operating instructions
- Always install the pump in the well above the screen section
- Water level: Minimum coverage of pump 1 m
- Distance from well floor: min. 0.5 m
- Well diameter for 4" submersible pumps: at least 4 1/2"; preferably 5" or 6"
- Position second type plate for the pump in the switch box
- Observe the current velocity at the motor
- Never let the pump run against closed valves
- Check the pump's direction of rotation when installed
- Use motor protection switch of inertia class 2.
Recommendation for 4" submersible motors 3 x 400 V 50 Hz: Use comfort motor protection
- Submersible cable: Cable connection can only be carried out by specialists under workshop conditions
- Annual maintenance Check the performance and installation of the pump

Soft starter operation

The start-up voltage is at least 65% of the calculated voltage.

If greater starting torque is needed or the power supply is not optimal, the starting torque should be higher.

Start-up time (before the calculated voltage is reached):

- Max. 3 s
- Run-down time: Max. 3 s

If these start-up and run-down ramps are followed, unnecessary heating of the motor is prevented.

If the soft starter is equipped with bypass guards, this will only operate during start-up and run-down.

This reduces the load on the soft starter and energy is conserved when compared with operation without bypass guards.

A soft starter cannot be used in combination with generator operation.

GWE 4" submersible pump with geothermal range motor

Product description

GWE submersible motor pump with range motor for water/ water geothermal applications up to 14 m³/h yield.

Benefits

- Available range from 1.5 to 14 m³/h yield
- All materials that come in contact with media are stainless steel
- Wide selection for pump head up to at least 50 m
- Range motor
- Questionnaire to determine pump head

Limits of use

- Conveyance of untreated water without abrasive or long-fibered components. Max. sand content 50 g/cm³
- The conveying medium must not chemically attack the pump materials
- Max. media temperature 30 °C
- Switch-on frequency max. 20 x/h and max. 200 x/day
- Max. external pressure for motor 35 bar

Technical data

- Pump rate 1.5; 3; 5; 8 and 14 m³/h
- Pressure head up to 50 m
- Motor voltages 3 x 400 V from 0.25 to 3 kW or 1 x 230 V from 0.37 up to 1.1 kW, 50 Hz
- Valve housing, intermediate chamber, wheel made of material 1.4301
- Shaft made of 1.4057
- Socket made of NBR

Accessories

Submersible cable with drinking water certificate, cooling jacket, switch box, stainless steel rope 2 mm, rope clamps, dry-run protection via electrode relay, screw fittings, PE coils

Packaging

Individually packaged, delivery via parcel shipment up to max. 30 kg



GWE high-efficiency submersible pump system

Product description

The complete solution to reduce operating costs and optimize your water collection.

Product characteristics

Highly efficient submersible pump in material 1.4301 with connection option for ZSM riser pipe.

Benefits

- Up to 20% energy savings in combination with synchronous motors reduces your costs and protects the environment
- Up to 13% motor efficiency enhancement reduces the operating temperature of the motor and increases the service life of the installation
- Motor power reduction up to 25%; smaller cable diameter, less capacity loss in the cable, reduces the power loss in the cable from the power in-feed to the submersible motor

Design

Multi-stage submersible pumps mounted with synchronous motor in currently available power range of 2.2 to 130 kW. For operation, a frequency converter is always required.

Technical data

4", 6", 8" and larger from 3 to 300 m³/h

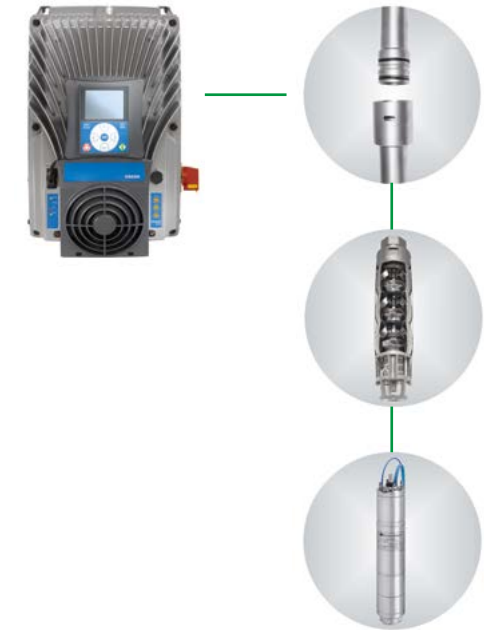

Accessories

Cable, cable connector, filter with and without housing, PT-100 sensor, expansion module, joints for riser pipe

Packaging

Individually packaged with testing certificate, if desired

GWE sampling system MP 1

Product description

2" sampling pump for groundwater measuring points.
Available cable lengths 30, 60 and 90 m.
Operates using a frequency converter.

Product characteristics

Use in all 2" to 4" groundwater measuring points.
Note: Continuous operation for water supply is not possible!

Benefits

- Small diameter
- Easy installation thanks to low weight
- Repair-friendly design

Design

The MP 1 is operated via a controllable frequency converter. The hydraulics and motor are a single unit that is easy to un-install for cleaning or when replacing wear parts. All parts are manufactured using chemically neutral materials that do not risk influencing or distorting samples.

Technical data

- Yield: 0 to 2.5 m³/h; Pump head: 0 to 98 m
Media temperature 1 to 35 °C
- Material: 1.4401 Power consumption 1.3 kW Voltage 3 x 230 V, 400 Hz
- Max diameter = 45 mm, Length = 287 mm, Weight = 2.4 kg

Packaging (if required)

Individually packaged, delivered without motor fluid (must be filled before commissioning!)



The motor is a fluid-filled canned submersible motor. The power supply is provided by a Teflon cable. The cable is exchangeable and available in three lengths. The frequency converter is specially designed for use with the MP 1 and includes motor protection for the pump.

Accessories (if required)

- Cable sets, frequency converter, PVC riser pipe DN 20, joints, stainless steel rope, rope clamps,
- wear part set, cable installation set

Centrifugal pumps

Product description

The centrifugal pumps are vertical multi-stage end suction high-pressure centrifugal pumps which are used for high-pressure applications such as water supply, pressure boosters, washing and sprinkler systems. The pumps are made of gray cast iron and stainless steel (1.4301) and are suitable for pure clear water. Due to the inline design of the suction and pressure line, compact installation of the pumps is possible. It only takes several minutes to replace the cartridge seal; this does not require any special tools. It is unnecessary to dismantle the engine. The 3-phase asynchronous engines of the centrifugal pumps comply with energy efficiency class IE3 (premium efficiency).

Benefits

- Higher efficiency -> lower operating costs
- High reliability
- Compact and low-maintenance
- High pumping pressure
- Accessories such as switch boxes and pressure switch available

Design

The low-maintenance sleeve coupling transfers the force from the engine to the pump. The hydraulic headpiece acts as a support surface for the top-mounted engine. The base piece with suction and pressure line is formed by the pump foot. The interior parts of the pump are made of chromium nickel steel: they are corrosion-resistant and highly resistant to wear.

Technical data

- Extraction: between 15 and 150 m³/h (on request, centrifugal pumps less than 15 m³/h are available)
- Maximum pump head: up to 320 m
- Temperature range of media: +5 °C to +70 °C
- Maximum ambient temperature: +40 °C
- Operational pressure: max. 25 bar



Performance range of centrifugal pumps

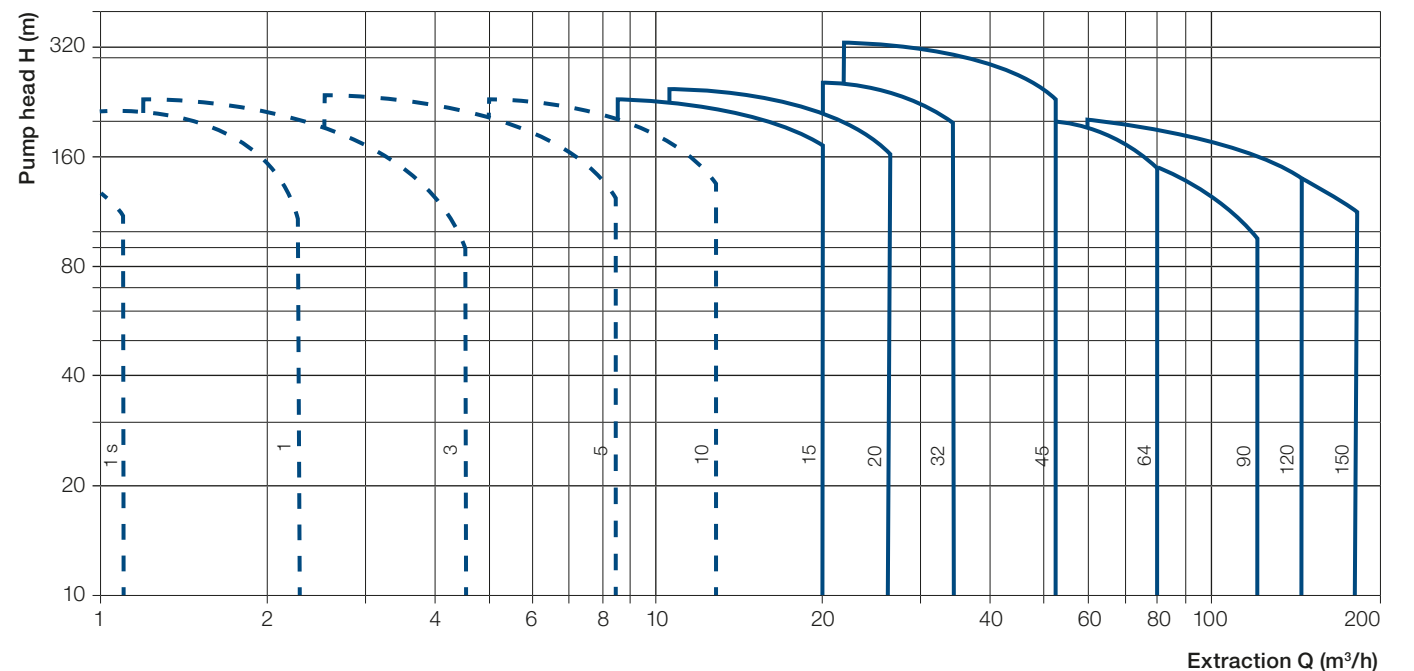

ROBU submersible motor pumps

Product description

The ROBU submersible motor pumps are used in various areas:

- Cold water (slightly contaminated water)
- Dirty liquid and wastewater (pumpable sludges)
- Rain water, ground water and wastewater (submersible construction pumps)

Clear water

Model code

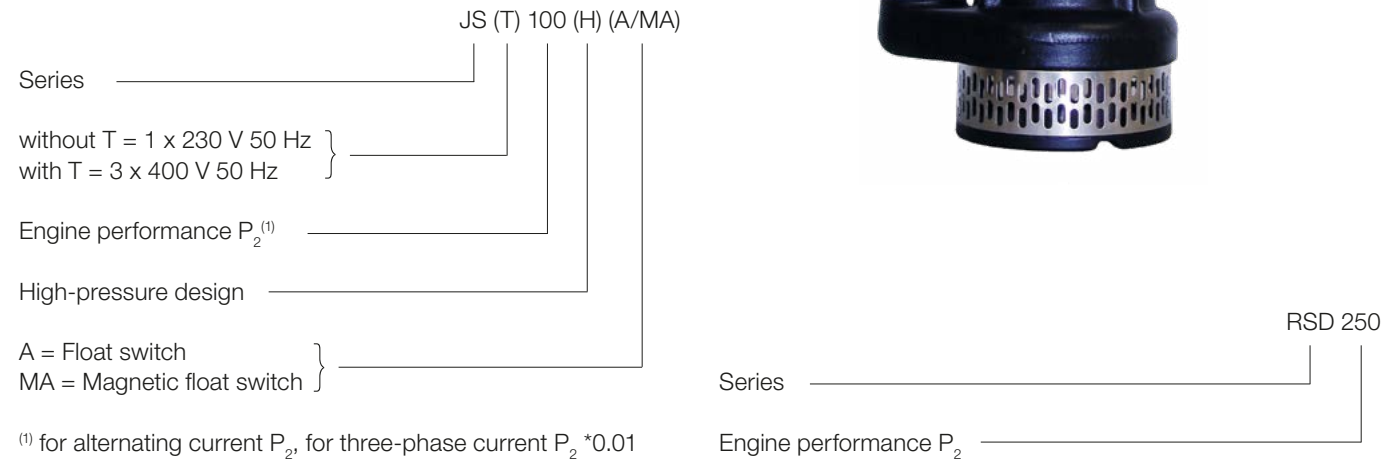

Technical data

	JS	JST	RSD
Extraction (m ³ /h)	Up to 32	Up to 120	Up to 15
Pump head (m)	Up to 24	Up to 42	Up to 11
Sieve, hole diameter (mm)	Up to 12	Up to 15	-
Media temperature (°C)	Max. 40	Max. 40	Max. 40
Power supply	1 x 230 V , 50 Hz	3 x 400 V , 50 Hz	1 x 230 V , 50 Hz
Extraction (mm)	-	-	1-2

Application

To pump clear to slightly contaminated water without fibrous admixtures.

For stationary use or transportable in wet installation.

Safe continuous operation up to 40 °C with fully submerged pump.



Material

Construction component	Material				
	JS 100/150	JS 250/400	JS 750/1500 (H)	JST / JST (H)	RSD
Housing sleeve	-	-	-	-	Stainless steel 1.4301
Motor housing	Stainless steel 1.4301	Stainless steel 1.4301	Stainless steel 1.4301	Stainless steel 1.4301	Grey cast iron EN GJL 250
Motor head	Polycarbonate	Grey cast iron EN GJL 250	Grey cast iron EN GJL 250	Grey cast iron EN GJL 250	Grey cast iron EN GJL 250
Pump housing	Grey cast iron EN GJL 250	Grey cast iron EN GJL 250	Grey cast iron EN GJL 250	Grey cast iron EN GJL 250	Grey cast iron EN GJL 250
Wheel	Polycarbonate	Polycarbonate	Grey cast iron EN GJL 250	Grey cast iron EN GJL 250	Grey cast iron EN GJL 250
Sieve	Stainless steel 1.4301	Stainless steel 1.4301	Stainless steel 1.4301	Stainless steel 1.4301	-
Handle	Polycarbonate	Stainless steel 1.4301	Stainless steel 1.4301	Stainless steel 1.4301	-

You can find more detailed information in our data specifications at the following link:
https://gwe-gruppe.de/export/shared/documents/pdf/bre/gwe/ROBU_2017.pdf



Type	Engine performance P ₂ (kW)	Nominal current (A)	1 x 230 V , 50 Hz Q = Extraction (m ³ /h) (Optimum operating performance - grease) H = Pump head (m)						
			Q	0	1	2	3	4	5
JS 100	0.1	1.2	Q	0	1	2	3	4	5
			H	6	5.5	5	3	2.5	1
JS 150	0.15	1.5	Q	0	2	3.5	5	6	7
			H	7	6	5	3.5	3	1
JS 250	0.3	1.8	Q	0	2	4	6	9	11
			H	9.5	9	8	7	4.5	3
JS 400	0.4	3.6	Q	0	3	6	10	12	15
			H	11	10	9	6	5	1
JS 750	0.75	7.5	Q	0	5	12	15	20.5	23
			H	15	13	10	8	5	2
JS 1500	1.5	13.0	Q	0	5	10	20	25	32
			H	18	17	15	11	7	2
JS 1500 H	1.5	13.0	Q	0	5	10	20	25	31
			H	24.5	22	20	14.5	10.5	5

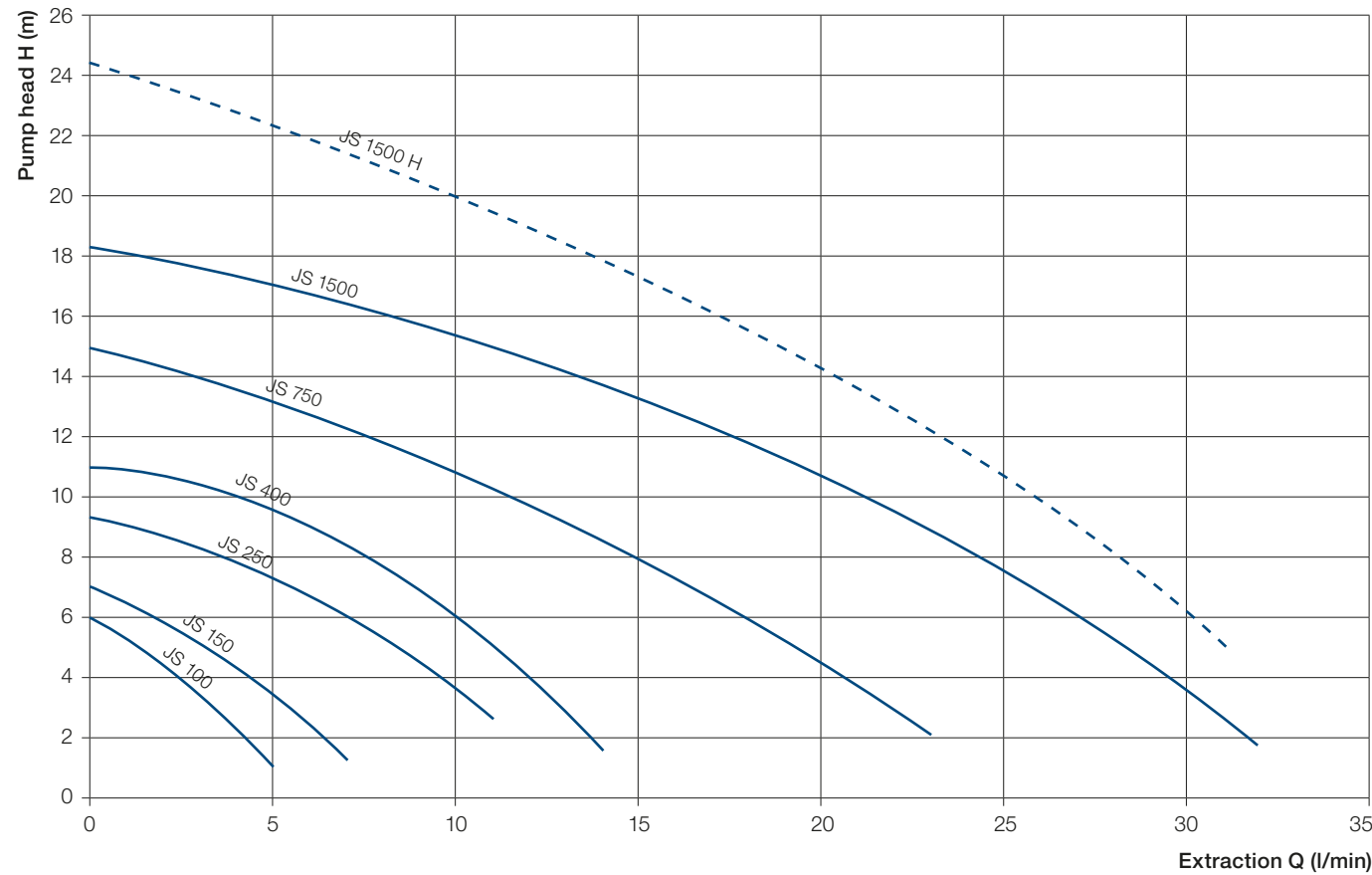

Model	Power		Voltage	Nominal current	H _{max}	Q _{max}	Sieve diameter	Pressure joints	Dimensions					Weight
	P ₁ (kW)	P ₂ (kW)							50 Hz	(A)	(m)	(m ³ /h)	(mm)	
JS 100	0.20	0.10	230V ~ 1 ph	1.0	6.0	5.0	4	1 1/4"	245	57	78	165	123	5.0
JS 100 A	0.20	0.10	230V ~ 1 ph	1.0	6.0	5.0	4	1 1/4"	245	57	78	165	123	5.5
JS 100 MA	0.20	0.10	230V ~ 1 ph	1.0	6.0	5.0	4	1 1/4"	245	57	78	165	123	5.5
JS 150	0.25	0.15	230V ~ 1 ph	1.5	7.0	7.0	4	1 1/4"	260	60	78	165	123	5.5
JS 150 A	0.25	0.15	230V ~ 1 ph	1.5	7.0	7.0	4	1 1/4"	260	60	78	165	123	6.0
JS 150 MA	0.25	0.15	230V ~ 1 ph	1.5	7.0	7.0	4	1 1/4"	260	60	78	165	123	6.0
JS 250	0.40	0.25	230V ~ 1 ph	1.8	9.5	11.0	6	1 1/2"	365	83	98	204	149	9.0
JS 250 A	0.40	0.25	230V ~ 1 ph	1.8	9.5	11.0	6	1 1/2"	365	83	98	204	149	9.5
JS 250 MA	0.40	0.25	230V ~ 1 ph	1.8	9.5	11.0	6	1 1/2"	365	83	98	204	149	9.5
JS 400	0.60	0.40	230V ~ 1 ph	3.6	11.0	15.0	6	2"	410	87	104	215	149	10.0
JS 400 A	0.60	0.40	230V ~ 1 ph	3.6	11.0	15.0	6	2"	410	87	104	215	149	10.5
JS 400 MA	0.60	0.40	230V ~ 1 ph	3.6	11.0	15.0	6	2"	410	87	104	215	149	10.5
JS 750	1.2	0.75	230V ~ 1 ph	7.5	15.0	23.0	8	2"	475	106	132	255	193	24.0
JS 750 A	1.2	0.75	230V ~ 1 ph	7.5	15.0	23.0	8	2"	475	106	132	255	193	24.5
JS 1500	2.2	1.5	230V ~ 1 ph	13.0	18.0	32.0	12	3"	510	170	150	285	190	49.0
JS 1500 H	2.2	1.5	230V ~ 1 ph	13.0	24.0	31.0	12	2"	510	170	150	285	190	49.0

Type	Engine performance P ₂ (kW)	Nominal current (A)	3 x 400 V , 50 Hz Q = Extraction (m ³ /h) (Optimum operating performance - grease) H = Pump head (m)						
			Q	0	7	12	16	20	24
JST 08	0.75	2.0	Q	0	7	12	16	20	24
			H	15	12.5	10	7.5	5	2
JST 15	1.5	3.4	Q	0	5	10	20	25	32
			H	18	17.5	15.5	11	7.5	2
JST 15 H	1.5	3.4	Q	0	5	10	15	25	31
			H	24.5	23	20	17	11	5
JST 22	2.2	5.0	Q	0	10	25	40	50	63
			H	20	18	15	10	7	1
JST 22 H	2.5	5.0	Q	0	20	30	40	45	55
			H	24.5	19	16	11	8	2
JST 37	3.7	7.5	Q	0	20	35	45	60	73
			H	23	19	15	12	7	1
JST 37 H	3.7	7.5	Q	0	17	30	40	50	60
			H	30	25	20	16	10	1
JST 55	5.5	11.0	Q	0	40	65	80	100	110
			H	25	20	15	12	5	2
JST 75	7.5	16.0	Q	0	25	50	80	100	120
			H	32	29	24	17	10	2

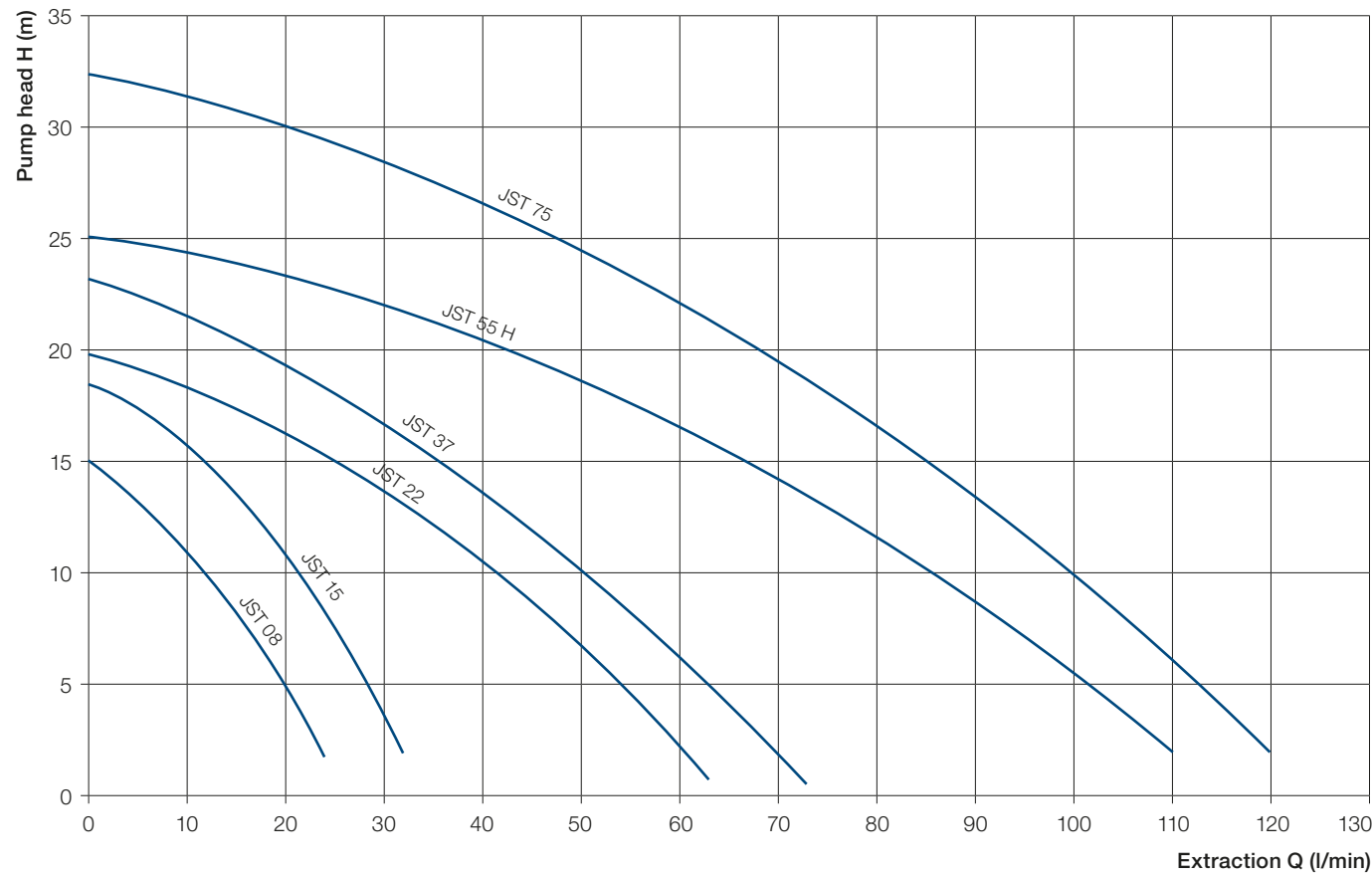
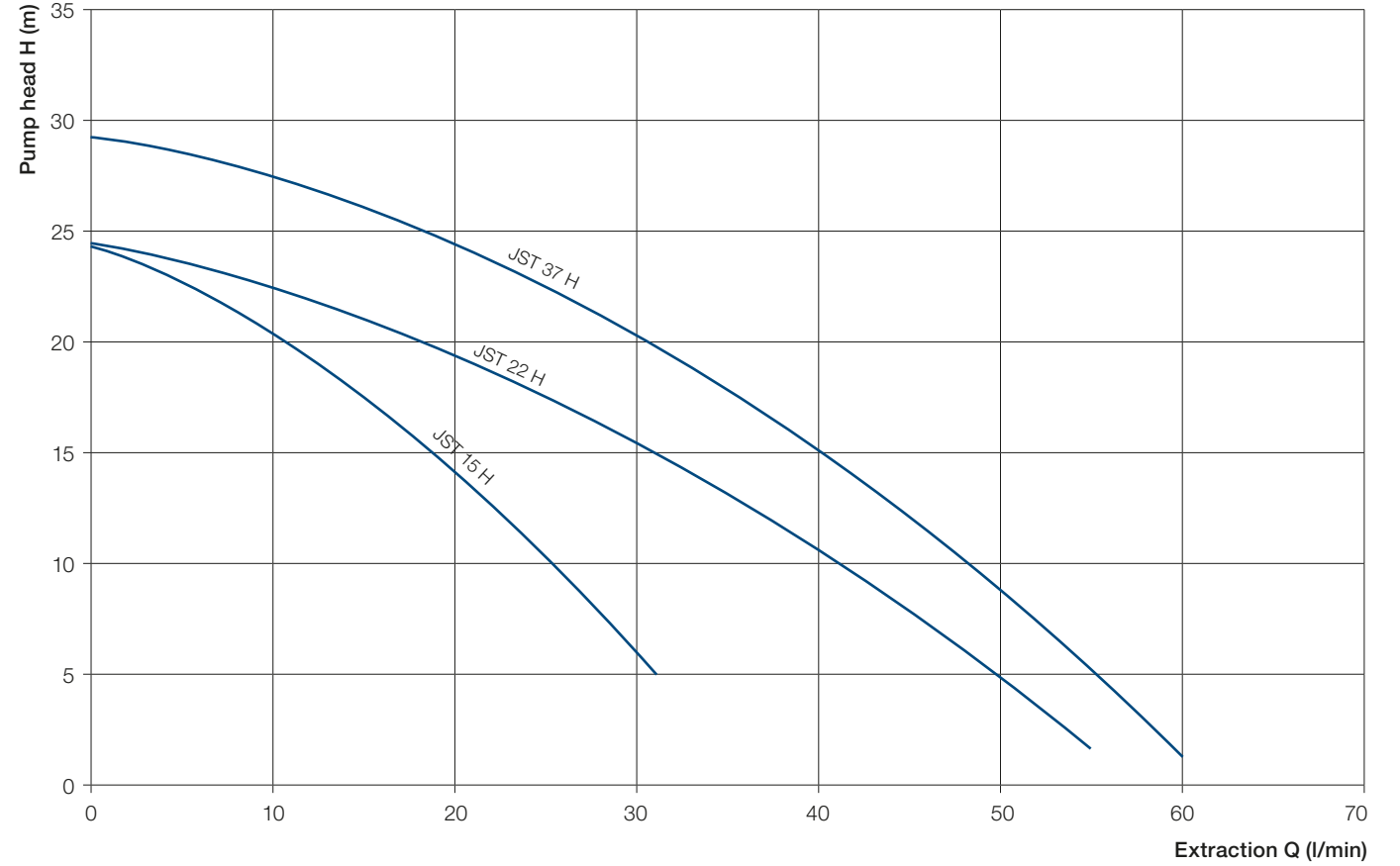

Model	Power		Voltage	Nominal current	H _{max} (m)	Q _{max} (m ³ /h)	Sieve diameter (mm)	Pressure joints R	Dimensions					Weight (kg)
	P ₁ (kW)	P ₂ (kW)							50 Hz	(A)	(m)	(m ³ /h)	(mm)	
JST 08	1.2	0.8	400V ~ 3 ph	2.0	15.0	24.0	8	2"	421	106	132	255	193	21.0
JST 15	2.2	1.5	400V ~ 3 ph	3.4	18.0	32.0	12	3"	447	106	132	285	190	26.0
JST 15 H	2.2	1.5	400V ~ 3 ph	3.4	24.5	31.0	12	2"	447	106	132	285	190	26.0
JST 22	3.5	2.2	400V ~ 3 ph	5.0	20.0	63.0	12	3"	503	170	150	313	223	39.0
JST 22 H	3.5	2.5	400V ~ 3 ph	5.0	24.5	55.0	12	2"	503	170	150	313	223	39.0
JST 37	5	3.7	400V ~ 3 ph	7.5	23.0	73.0	15	3"	518	170	150	325	223	45.0
JST 37 H	5	3.7	400V ~ 3 ph	7.5	30.0	60.0	15	2"	518	170	150	325	223	45.0
JST 55	7.5	5.5	400V ~ 3 ph	11.0	25.0	110.0	15	4"	651	242	200	580	270	65.0
JST 75	12	7.5	400V ~ 3 ph	16.0	32.0	118.0	15	4"	704	242	200	655	270	75.0
JS 400	0.60	0.40	230V ~ 1 ph	3.6	11.0	15.0	6	2"	410	87	104	215	149	10.0
JS 400 A	0.60	0.40	230V ~ 1 ph	3.6	11.0	15.0	6	2"	410	87	104	215	149	10.5
JS 400 MA	0.60	0.40	230V ~ 1 ph	3.6	11.0	15.0	6	2"	410	87	104	215	149	10.5
JS 750	1.2	0.75	230V ~ 1 ph	7.5	15.0	23.0	8	2"	475	106	132	255	193	24.0
JS 750 A	1.2	0.75	230V ~ 1 ph	7.5	15.0	23.0	8	2"	475	106	132	255	193	24.5
JS 1500	2.2	1.5	230V ~ 1 ph	13.0	18.0	32.0	12	3"	510	170	150	285	190	49.0
JS 1500 H	2.2	1.5	230V ~ 1 ph	13.0	24.0	31.0	12	2"	510	170	150	285	190	49.0

Type	Engine performance P ₂ (kW)	Nominal current (A)	1 x 230 V , 50 Hz Q = Extraction (m ³ /h) (Optimum operating performance - grease) H = Pump head (m)						
			Q	0	2	4	6	8	11
RSD 250	0.20	3.6	H	9.5	9	8	7	5	3
			Q	0	2	4	6	8	11
RSD 400	0.25	3.6	H	11	10	9	6	4	1.5
			Q	0	4	6	10	12	15

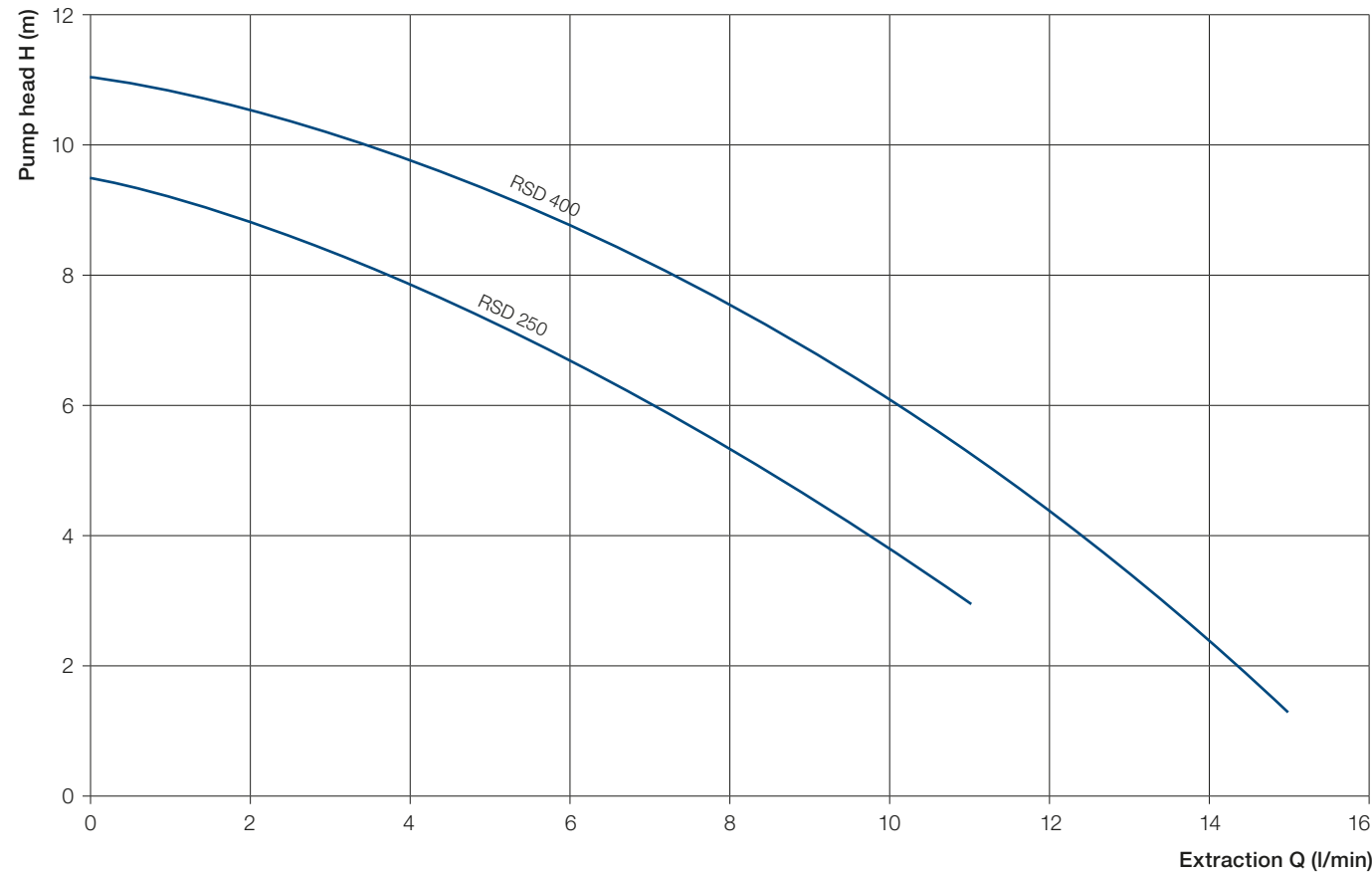

Model	Power		Voltage	Nominal current	H _{max}	Q _{max}	Pressure joints	Dimensions		Weight
	P ₁ (kW)	P ₂ (kW)						A (mm)	B (mm)	
RSD 250	0.4	0.2	230V ~ 1 ph	3.6	9.5	11.0	1"	380	185	12.8
RSD 400	0.5	0.25	230V ~ 1 ph	3.6	11.0	15.0	1 1/4"	380	185	13.0

Dirty liquid and wastewater

Model code

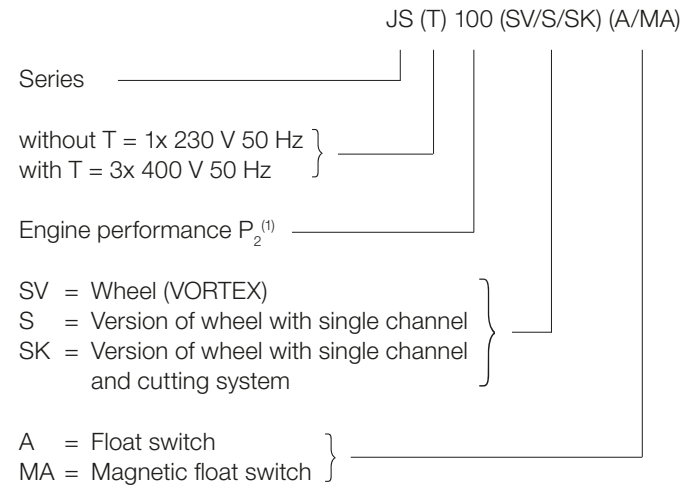

⁽¹⁾ for alternating current P₂, for three-phase current P₂ *0.01

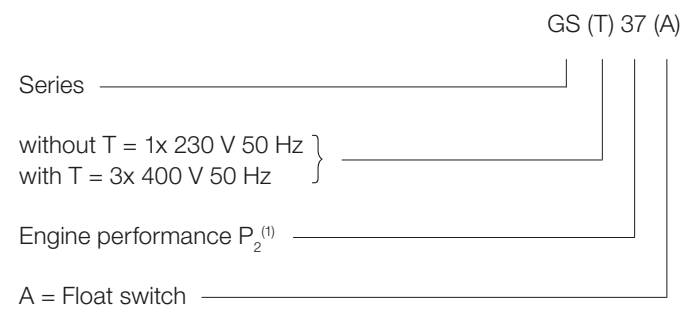

⁽¹⁾ for alternating current P₂, for three-phase current P₂ *0.01

Technical data

	JS-SV	JST-SV	JS-S/SK	JST-S/SK	GS	GST
Extraction (m ³ /h)	Up to 40	Up to 180	Up to 48	Up to 144	Up to 9	Up to 19
Pump head (m)	Up to 15	Up to 16	Up to 18	Up to 32	Up to 25	Up to 35
Free passage (mm)	Up to 65	Up to 100	45	Up to 70	-	-
Media temperature (°C)	Max. 40	Max. 40	Max. 40	Max. 40	Max. 40	Max. 40
Power supply	1 x 230 V, 50 Hz	3 x 400 V, 50 Hz	1 x 230 V, 50 Hz	3 x 400 V, 50 Hz	1 x 230 V, 50 Hz	3 x 400 V, 50 Hz

Application

Pumping of dirty liquid, wastewater and pumpable sludges such as sewage sludge, factory wastewater, fecal matter and domestic wastewater. The SK series is particularly suited for pumping wastewater with coarse and long-fibered

components. The cutting system breaks down the admixtures into an easily flowing conveyable material. For stationary use or transportable in wet installation. Safe continuous operation up to 40 °C with fully submerged pump.



Construction component	Material					
	JS 150 SV	JS 250/400/600/750/1500 SV	JST-SV	JS-S/JS-SK	JST-S/JST-SK	GS/GST
Motor housing	Stainless steel 1.4301	Stainless steel 1.4301	Stainless steel 1.4301	Stainless steel 1.4301	Stainless steel 1.4301	Grey cast iron EN GJL 250
Motor head	Polycarbonate	Grey cast iron EN GJL 250	Grey cast iron EN GJL 250	Grey cast iron EN GJL 250	Grey cast iron EN GJL 250	Grey cast iron EN GJL 250
Pump housing	Polycarbonate	Grey cast iron EN GJL 250	Grey cast iron EN GJL 250	Grey cast iron EN GJL 250	Grey cast iron EN GJL 250	Grey cast iron EN GJL 250
Wheel	Polycarbonate	Grey cast iron EN GJL 250	Grey cast iron EN GJL 250	Grey cast iron EN GJL 250 SK: with wolfram carbide reinforced shear edge	Grey cast iron EN GJL 250 SK: with wolfram carbide reinforced shear edge	Grey cast iron EN GJL 250
Handle	Stainless steel 1.4301	Stainless steel 1.4301	Stainless steel 1.4301	Stainless steel 1.4301	Stainless steel 1.4301	Stainless steel 1.4301
Base support foot (SK with cutting plate)	-	-	-	Grey cast iron EN GJL 250	Grey cast iron EN GJL 250	Grey cast iron EN GJL 250
Cutting wheel Cutting ring	-	-	-	-	-	Carbide

You can find more detailed information in our data specifications at the following link:
https://gwe-gruppe.de/export/shared/documents/pdf/bre/gwe/ROBU_2017.pdf

Type	Engine performance P ₂ (kW)	Nominal current (A)	1 x 230 V , 50 Hz Q = Extraction (m ³ /h) (Optimum operating performance - grease) H = Pump head (m)						
			Q	0	2	3	4.5	5	7
JS 150 SV	0.15	1.5	Q	0	2	3	4.5	5	7
			H	6	5	4	3	2	0
JS 250 SV	0.25	1.8	Q	0	2.1	4	6	8.4	13.2
			H	6	5.5	5	4	3	0
JS 400 SV	0.4	2.8	Q	0	3	6	9	12	13.5
			H	6.7	6.3	5.5	4	2.2	1
JS 650 SV	0.75	6.8	Q	0	3	6	8	12	15
			H	15	14	12.5	11.5	8.5	6
JS 750 SV	0.75	6.8	Q	0	3	6	12	18	23
			H	9.5	9	8.4	6.3	4.2	2
JS 1,500 SV	1.5	13.0	Q	0	6	12	18	30	39
			H	9	8.2	7.2	6.2	4	2

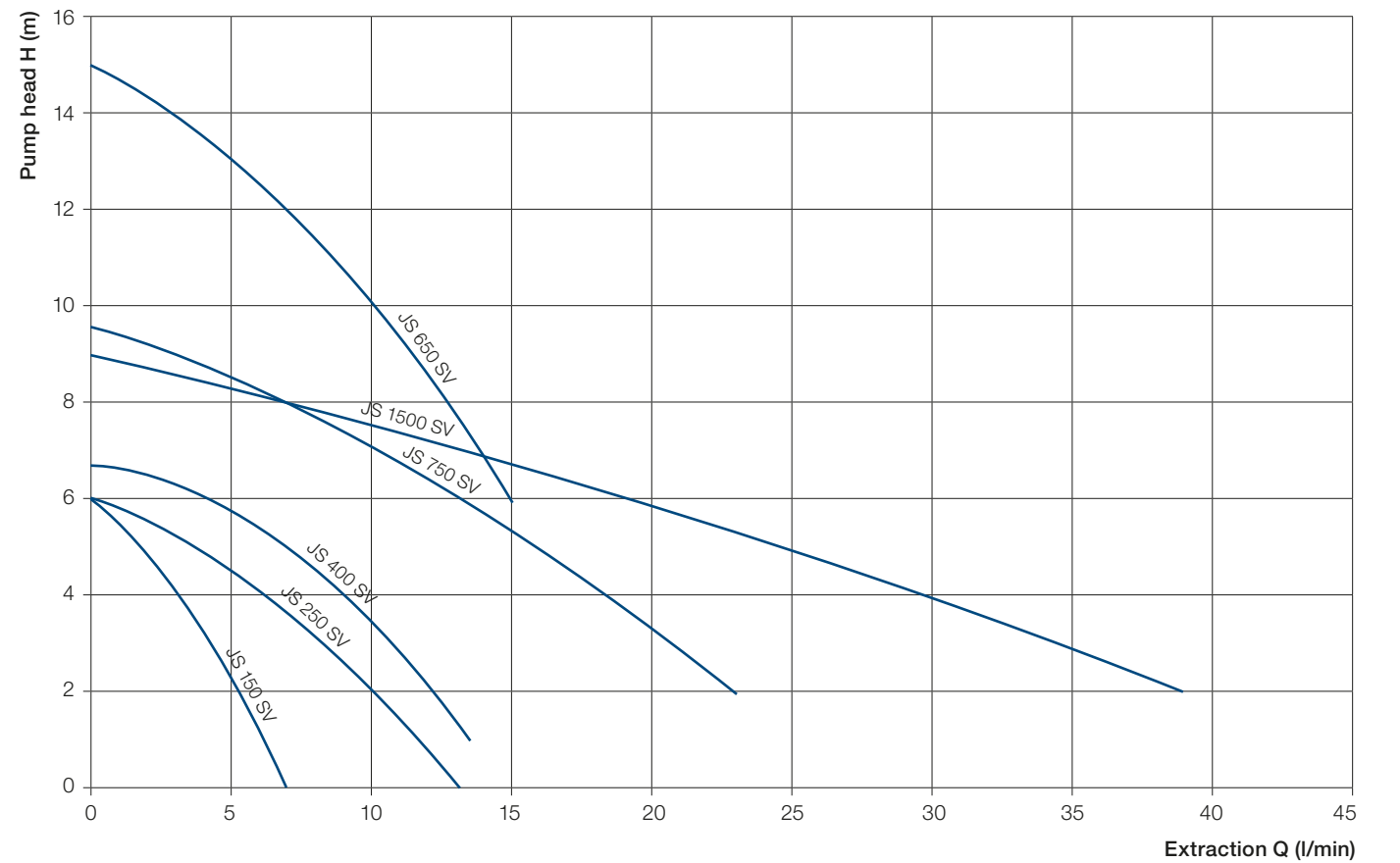

Model	Power		Voltage	Nominal current	H _{max}	Q _{max}	Grain size	Pressure joints	Dimensions					Weight
	P ₁ (kW)	P ₂ (kW)							50 Hz	(A)	(m)	(m³/h)	(mm)	
JS 150 SV	0.3	0.15	230V ~ 1 ph	1.5	6.0	7.0	25	1 1/4"	270	75	78	164	120	5.5
JS 150 SVA	0.3	0.15	230V ~ 1 ph	1.5	6.0	7.0	25	1 1/4"	270	75	78	164	120	6.0
JS 150 SVMA	0.3	0.15	230V ~ 1 ph	1.5	6.0	7.0	25	1 1/4"	270	75	78	164	120	6.0
JS 250 SV	0.4	0.25	230V ~ 1 ph	1.8	6.0	13.0	35	1 1/2"	340	120	108	215	135	12.0
JS 250 SVA	0.4	0.25	230V ~ 1 ph	1.8	6.0	13.0	35	1 1/2"	340	120	108	215	135	12.5
JS 250 SVMA	0.4	0.25	230V ~ 1 ph	1.8	6.0	13.0	35	1 1/2"	340	120	108	215	135	12.5
JS 400 SV	0.6	0.4	230V ~ 1 ph	2.7	7.0	14.0	35	2"	400	120	108	215	135	13.0
JS 400 SVA	0.6	0.4	230V ~ 1 ph	2.7	7.0	14.0	35	2"	400	120	108	215	135	13.5
JS 400 SVMA	0.6	0.4	230V ~ 1 ph	2.7	7.0	14.0	35	2"	400	120	108	215	135	13.5
JS 650 SV	1.2	0.75	230V ~ 1 ph	6.8	15.0	15.0	35	2"	480	152	132	280	170	21.0
JS 650 SVA	1.2	0.75	230V ~ 1 ph	6.8	15.0	15.0	35	2"	480	152	132	280	170	21.0
JS 750 SV	1.2	0.75	230V ~ 1 ph	6.8	10.0	23.0	45	3"	480	152	132	280	170	22.0
JS 750 SVA	1.2	0.75	230V ~ 1 ph	6.8	10.0	23.0	45	3"	480	152	132	280	170	22.5
JS 1,500 SV	2.2	1.5	230V ~ 1 ph	13.0	9.0	39.0	65	3"	508	250	205	388	185	47.0

Type	Engine performance P ₂ (kW)	Nominal current (A)	3 x 400 V , 50 Hz Q = Extraction (m³/h) (Optimum operating performance - grease) H = Pump head (m)						
			Q	0	3	6	12	18	23
JST 08 SV	0.75	2.0	H	9.5	9	8.5	6	4	2
			Q	0	3	6	12	18	23
JST 15 SV	1.5	3.4	H	9	8.5	7	6	4	2
			Q	0	6	12	20	30	39
JST 22 SV	2.2	5.0	H	10	8.5	7	5.5	3.5	1
			Q	0	12	25	35	50	62
JST 37 SV	3.7	8.0	H	13.5	11	9	7.5	5.5	2.5
			Q	0	25	40	50	60	72
JST 55 SV	5.5	11.0	H	14	13	11	9	6	4
			Q	0	30	60	90	120	140

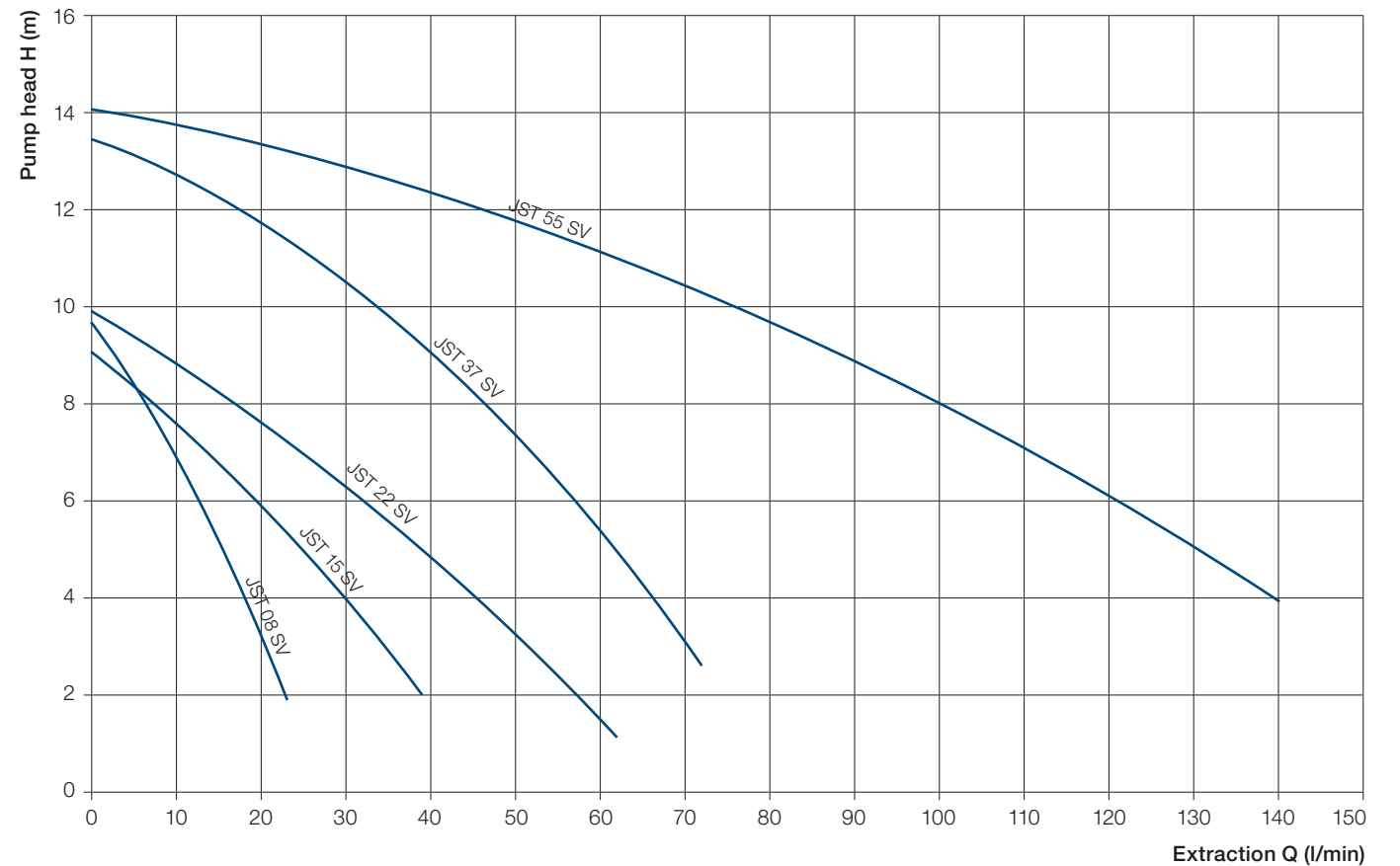

Model	Power		Voltage	Nominal current	H _{max}	Q _{max}	Grain size	Pressure joints	Dimensions					Weight
	P ₁ (kW)	P ₂ (kW)							50 Hz	(A)	(m)	(m³/h)	(mm)	
JST 08 SV	1.2	0.8	400V ~ 3 ph	2.0	9.0	23.0	45	3"	420	152	132	280	170	21.0
JST 15 SV	2.2	1.5	400V ~ 3 ph	3.4	9.0	39.0	65	3"	450	250	205	388	185	23.0
JST 22 SV	3.5	2.2	400V ~ 3 ph	5.0	10.0	62.0	65	3"	580	290	238	465	255	39.0
JST 37 SV	5	3.7	400V ~ 3 ph	8.0	13.0	72.0	65	3"	610	290	238	465	255	45.0
JST 55 SV	7.5	5.5	400V ~ 3 ph	11.0	14.0	150.0	100	4"	765	360	425	660	315	100.0

Type	Engine performance P ₂ (kW)	Nominal current (A)	1 x 230 V , 50 Hz Q = Extraction (m ³ /h) (Optimum operating performance - grease) H = Pump head (m)						
			Q	0	5	10	15	17.5	20
JS 750 S	0.75	7.5	Q	0	5	10	15	17.5	20
			H	15	13	10	7	5	3
JS 750 SK	0.75	7.5	Q	0	5	10	15	17.5	20
			H	15	13	10	7	5	3
JS 1,500 S	1.5	13.0	Q	0	10	15	22	30	37
			H	19	15	13	10	8	2.5
JS 1,500 SK	1.5	13.0	Q	0	10	20	30	40	48
			H	17	15	10.5	7	4	2

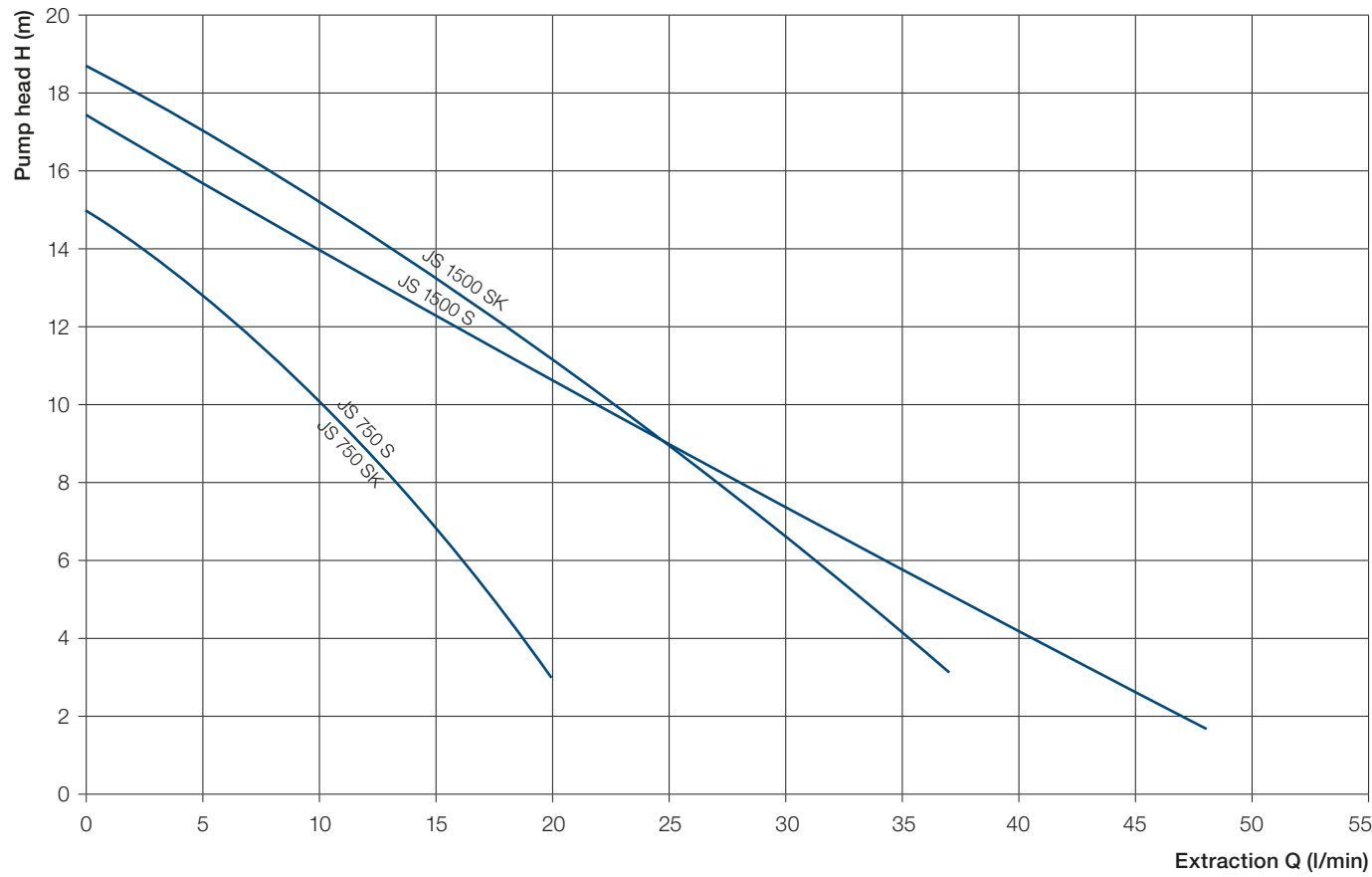

Model	Power		Voltage 50 Hz	Nominal current (A)	H _{max} (m)	Q _{max} (m ³ /h)	Grain size (mm)	Pressure joints R	Dimensions					Weight (kg)
	P ₁ (kW)	P ₂ (kW)							A (mm)	B (mm)	D (mm)	E (mm)	F (mm)	
JS 750 S	1.2	0.75	230V ~ 1ph	7.5	15	21	20	2"	480	167	136	290	190	27
JS 750 SA	1.2	0.75	230V ~ 1ph	7.5	15	21	20	2"	480	167	136	290	190	27
JS 750 SK	1.2	0.75	230V ~ 1ph	7.5	14	23	20	2"	480	167	136	290	190	27
JS 750 SKA	1.2	0.75	230V ~ 1ph	7.5	14	23	20	2"	480	167	136	290	190	27
JS 1,500 S	2.2	1.5	230V ~ 1ph	13	19	43	45	3"	555	205	150	310	210	35
JS 1,500 SK	2.2	1.5	230V ~ 1ph	13	17	48	45	3"	555	205	150	310	210	35

Type	Engine performance P ₂ (kW)	Nominal current (A)	3 x 400 V , 50 Hz Q = Extraction (m ³ /h) (Optimum operating performance - grease) H = Pump head (m)						
			Q	0	7.2	11	15	18	21
JST 08 S	0.75	2.0	Q	0	7.2	11	15	18	21
			H	15	12	9	7	5	2
JST 08 SK	0.75	2.0	Q	0	5	10	13	18	23
			H	14.5	12	10	8	5	2
JST 15 S	1.5	3.4	Q	0	10	15	20	30	43
			H	19	15	12.5	11	7	1
JST 15 SK (SS)*	1.5	3.4	Q	0	10	20	30	40	48
			H	17	14	11	7.5	4	1
JST 22 S	2.2	5.0	Q	0	10	20	30	45	55
			H	21	18	15	12	7	2
JST 22 SK	2.2	5.0	Q	0	15	30	40	50	63
			H	20	16	12	8	6	2
JST 37 S	3.7	7.5	Q	0	20	30	40	50	72
			H	26	20	17	13.5	11	3.5
JST 37 SK (SS)*	3.7	7.5	Q	0	20	30	40	50	72
			H	25	20	17	14	11	3.5
JST 55 S	5.5	11.0	Q	0	20	40	60	90	96
			H	23	19	16	13	5	3

*SS = Stainless Steel (stainless steel 1.4401, AISI 316)

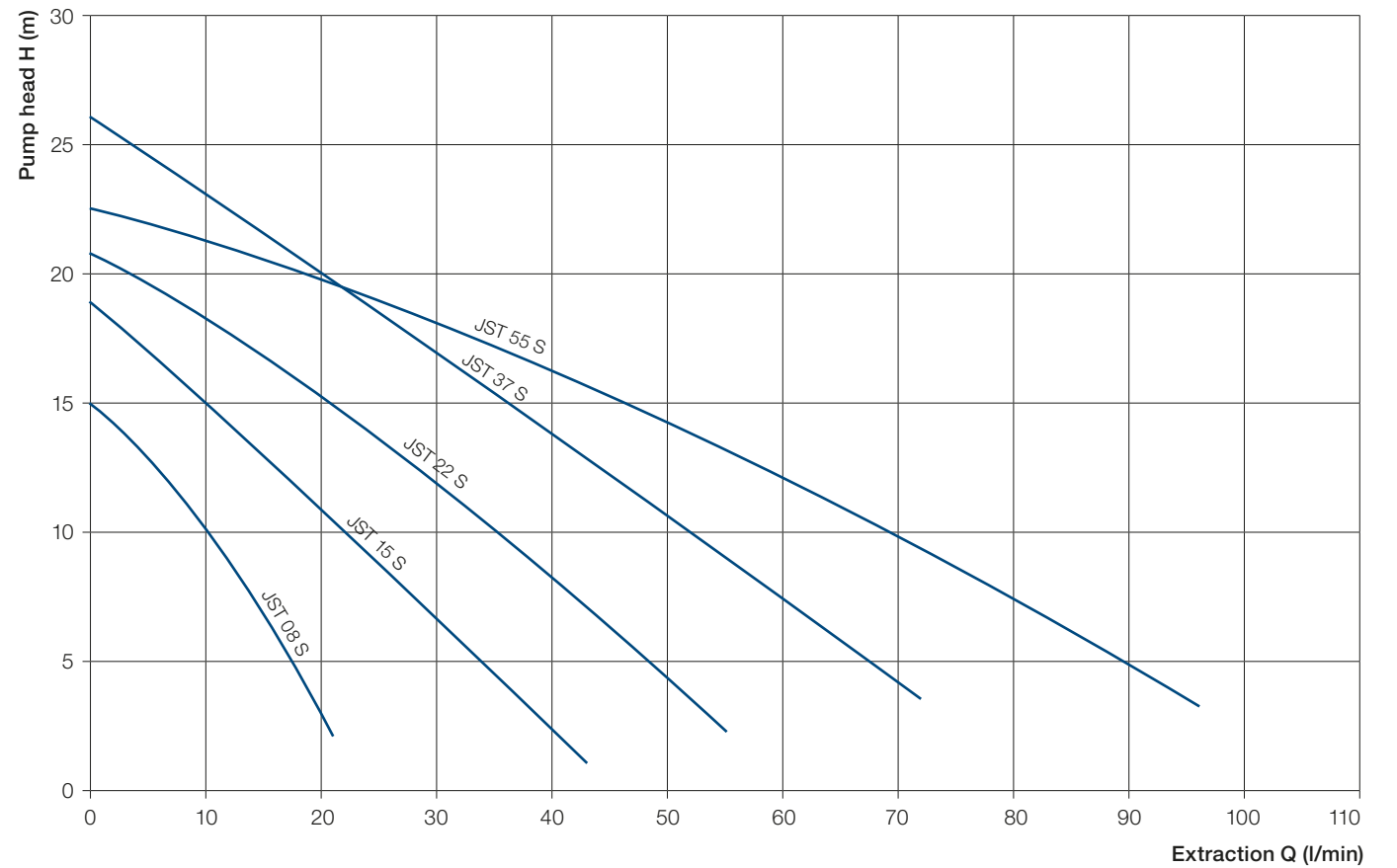

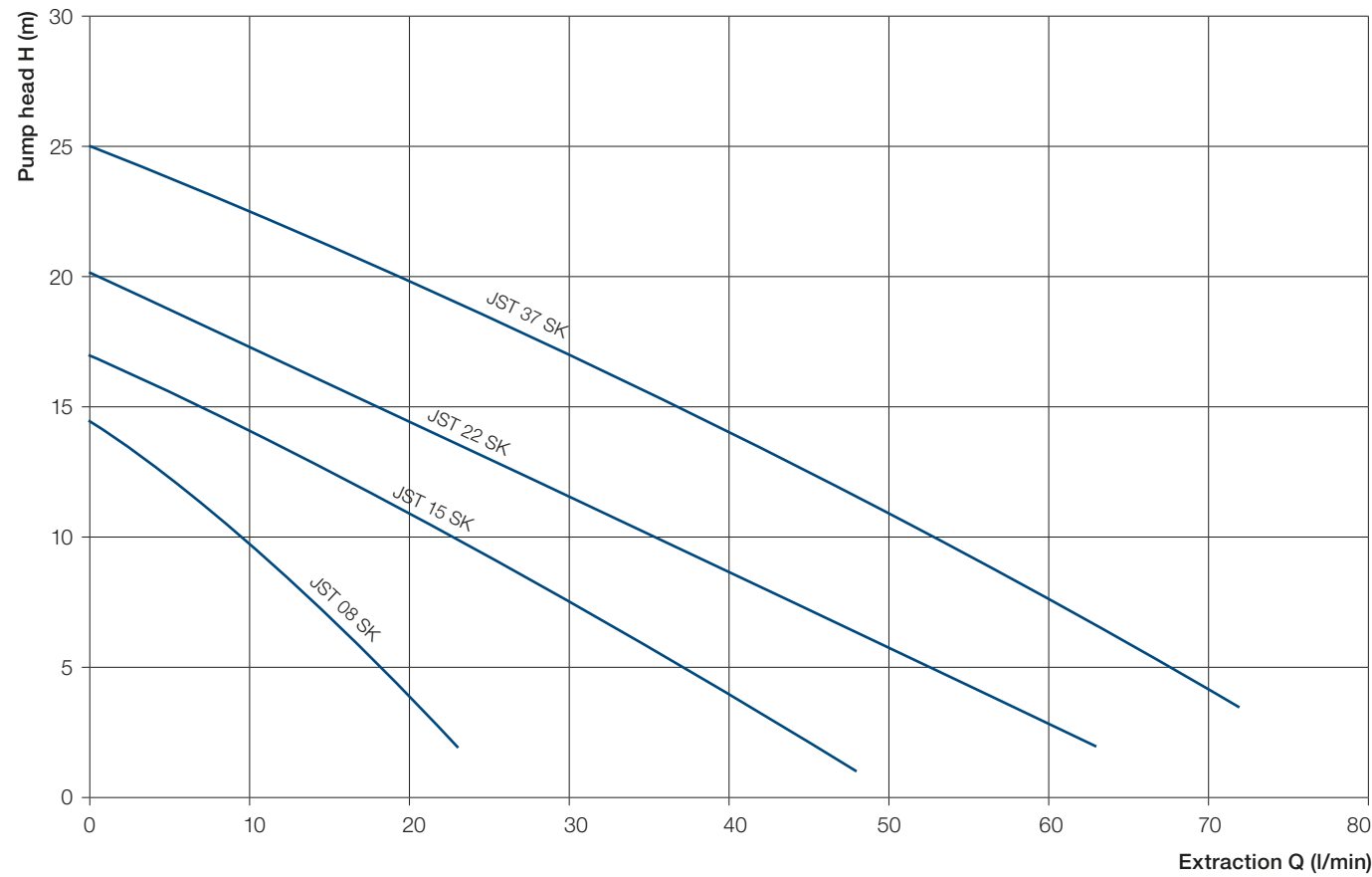

Model	Power		Voltage	Nominal current	H _{max}	Q _{max}	Grain size	Pressure joints	Dimensions					Weight
	P ₁ (kW)	P ₂ (kW)							50 Hz	(A)	(m)	(m ³ /h)	(mm)	
JST 08 S	1.2	0.8	400V ~ 3 ph	2.0	15.0	21.0	20	2"	462	167	136	315	192	27.0
JST 08 SK	1.2	0.8	400V ~ 3 ph	2.0	14.0	22.0	20	2"	462	167	136	315	192	30.0
JST 15 S	2.2	1.5	400V ~ 3 ph	3.4	19.0	43.0	45	3"	501	167	136	385	236	30.0
JST 15 SK (SS)*	2.2	1.5	400V ~ 3 ph	3.4	17.0	48.0	45	3"	501	167	136	385	236	38.0
JST 22 S	3.5	2.2	400V ~ 3 ph	5.0	21.0	57.0	45	3"	544	205	150	405	235	40.0
JST 22 SK	3.5	2.2	400V ~ 3 ph	5.0	20.0	63.0	45	3"	544	205	150	405	235	41.0
JST 37 S	5	3.7	400V ~ 3 ph	7.5	26.0	72.0	50	4"	598	205	150	405	241	44.0
JST 37 SK (SS)*	5	3.7	400V ~ 3 ph	7.5	25.0	72.0	50	4"	598	205	150	405	241	45.0
JST 55 S	7.5	5.5	400V ~ 3 ph	11.0	23.0	96.0	55	4"	718	242	200	502	298	65.0

*SS = Stainless Steel (stainless steel 1.4401, AISI 316)

Type	Engine performance P ₂ (kW)	Nominal current (A)	1 x 230 V , 50 Hz Q = Extraction (m ³ /h) H = Pump head (m)						
			Q	H	Q	H	Q	H	Q
GS 1,200/A	1.2	9.2	0	2	3	4	6	7	
			20	17	15	13	6	2	
GS 1,500/A	1.5	11.5	0	2	4	6	8	9.5	
			25	23.5	21.5	16	8	2	

Type	Engine performance P ₂ (kW)	Nominal current (A)	1 x 400 V , 50 Hz Q = Extraction (m ³ /h) H = Pump head (m)						
			Q	H	Q	H	Q	H	Q
GST 12	1.2	2.6	0	2	3	4	6	7	
			20	17	15	13	6.5	2	
GST 15	1.5	3.2	0	2	4	6	8	9.5	
			25	23.5	21.5	16	8	2	
GST 22	2.2	4.4	0	3	6	10	14	18	
			25	24.5	22	18	14.5	10	
GST 37	3.7	7.5	0	3	6	10	14	18	
			35	34	32	29	25.5	20	

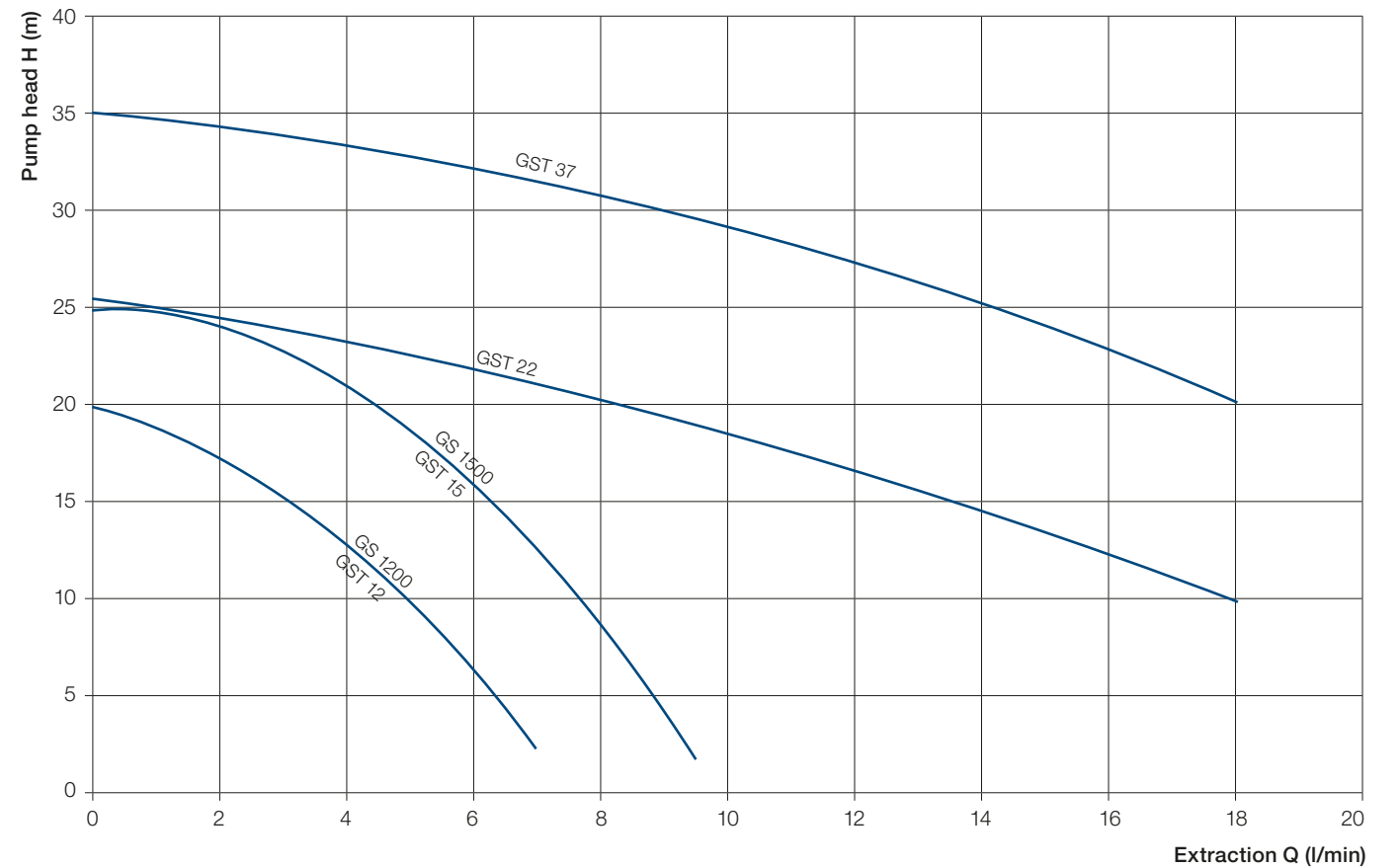

Model	Power		Voltage	Nominal current	H _{max}	Q _{max}	Pressure joints	Dimensions					Weight
	P ₁ (kW)	P ₂ (kW)						50 Hz	(A)	(m)	(m ³ /h)	R	
GS 1,200	1.75	1.2	230V ~ 1ph	9.2	20.0	7.0	1 1/4"	525	160	190	310	180	33.0
GS 1,500	2.2	1.5	230V ~ 1ph	11.5	25.0	9.0	1 1/4"	565	160	190	315	180	37.0
GST 12	1.75	1.2	400V ~ 3 ph	2.6	20.0	7.0	1 1/4"	500	160	190	315	180	30.0
GST 15	2.2	1.5	400V ~ 3 ph	3.0	25.0	9.0	1 1/4"	500	160	190	320	180	35.0
GST 22	3.5	2.2	400V ~ 3 ph	4.4	25.0	19.0	2"	565	160	205	340	240	50.0
GST 37	5	3.7	400V ~ 3 ph	7.5	35.0	19.0	2"	575	160	220	340	240	55.0

Rain water, ground water and wastewater

Model code

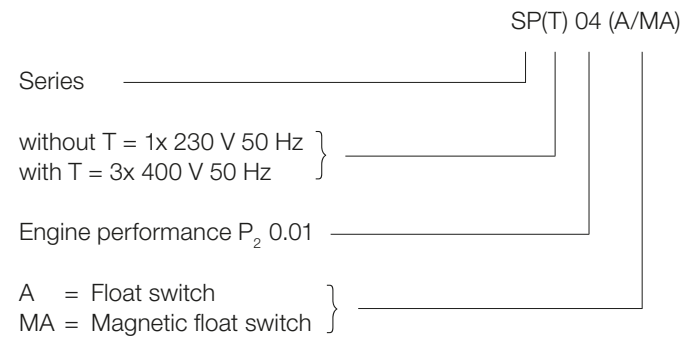

Technical data

	SP	SPT
Extraction (m³/h)	Up to 21	Up to 21
Pump head (m)	Up to 18	Up to 18
Free passage (mm)	Up to 7	Up to 7
Media temperature (°C)	Max. 40	Max. 40
Power supply	1 x 230 V , 50 Hz	3 x 400 V , 50 Hz

Application

Robust, wear-resistant and lightweight drainage pumps with agitator head for pumping sandy rainwater, groundwater or dirty liquid. Ideal for site dewatering.

For stationary use or transportable in wet installation. Safe continuous operation up to 40 °C with up to 3% solid soil particles.

Material

Construction component	Material
Handle	Nylon
Motor housing	Cast aluminum
Motor sheath	Cast aluminum
Pump housing	GGG70
EN-GJS-700-2	3 x 400 V , 50 Hz
Wheel	Metal-reinforced
polyurethane	
Agitator head	Carbide
Shaft	14,028
Mechanical seal	SIC/SIC
Lip seal	NBR
O-rings	NBR
Pump foot	PVC

You can find more detailed information in our data specifications at the following link:
https://gwe-gruppe.de/export/shared/documents/pdf/bre/gwe/ROBU_2017.pdf

Type	Engine performance P ₂ (kW)	Nominal current (A)	Q = Extraction (m³/h) (Optimum operating performance - grease) H = Pump head (m)									
			Q	0	3	7.2	9	12	14	-	-	-
SP 04	0.4	1.9	Q	0	3	7.2	9	12	14	-	-	-
			H	12	10	7	6	3	0	-	-	-
SP 08	0.75	6.5	Q	0	3	6	10	12	14	15	18	21
			H	18	16	14	12	10	8	7	4	0
SP(T) 04	0.4	0.9	Q	0	3	7.2	9	12	14	-	-	-
			H	12	10	7	6	3	0	-	-	-
SP(T) 08	0.75	1.8	Q	0	3	6	10	12	14	15	18	21
			H	18	16	14	12	10	8	7	4	0

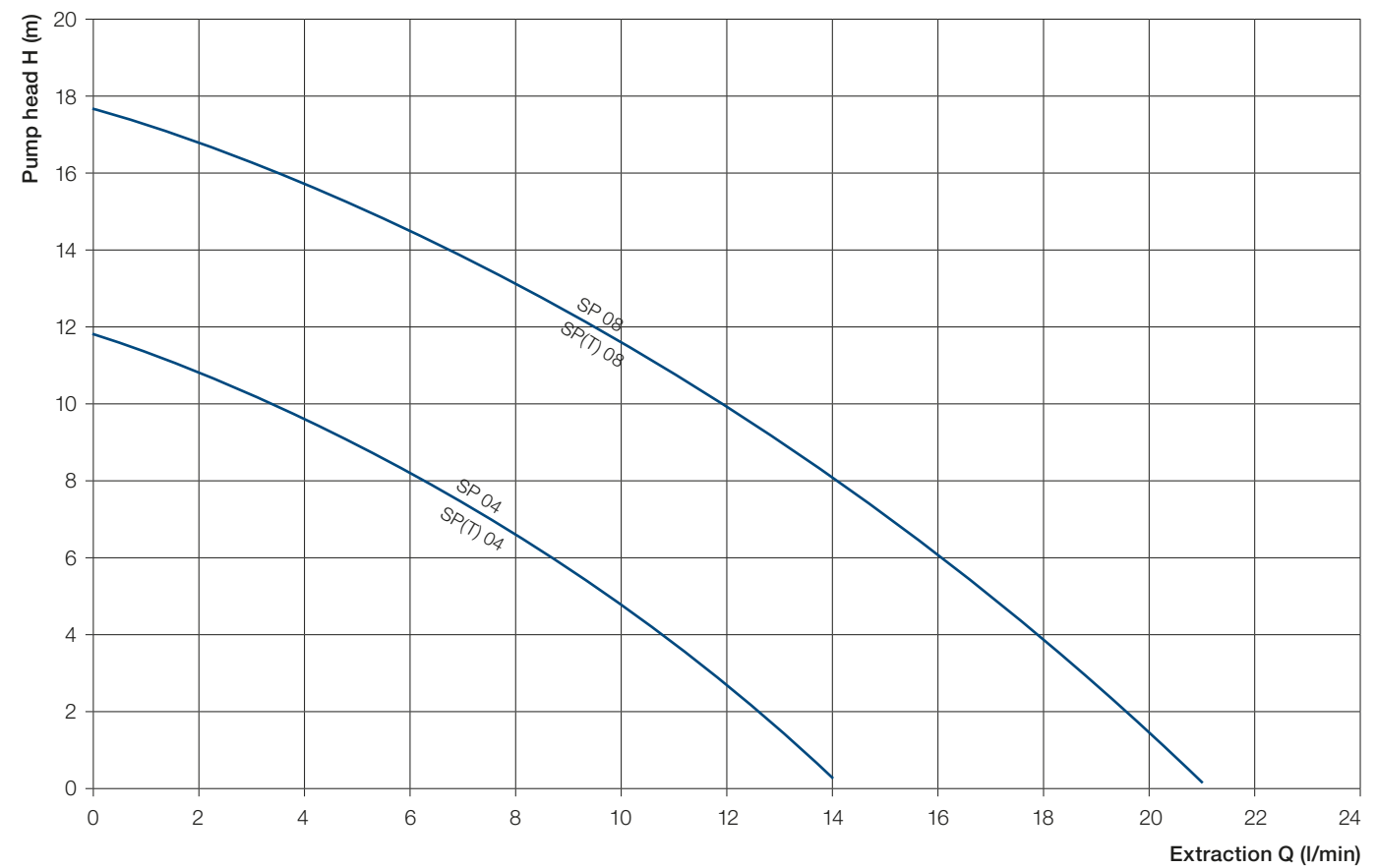

Model	Power		Voltage	Nominal current	Start-up current	H _{max}	Q _{max}	Particle size	Connection	Dimensions						Weight (kg)
	P ₁ (kW)	P ₂ (kW)								50 Hz	(A)	(A)	(m)	(m ³ /h)	(mm)	
SP 04	0.58	0.4	230 V ~ 1 ph	1.9	8.0	12.0	14.0	7	R 2"	343	90	200	249	95	120	12
SP 04 A	0.58	0.4	230 V ~ 1 ph	1.9	8.0	12.0	14.0	7	R 2"	343	200	400	249	95	120	12.5
SP 04 MA	0.58	0.4	230 V ~ 1 ph	1.9	8.0	12.0	14.0	7	R 2"	343	150	230	249	95	120	12.5
SP 08	1.15	0.75	230 V ~ 1 ph	6.5	15.0	18.0	21.0	7	Rp 2"	368	90	225	279	95	120	16
SP 08 A	1.15	0.75	230 V ~ 1 ph	6.5	15.0	18.0	21.0	7	Rp 2"	368	225	425	279	95	120	16.5
SP 08 MA	1.15	0.75	230 V ~ 1 ph	6.5	15.0	18.0	21.0	7	Rp 2"	368	175	255	279	95	120	16.5
SP(T) 04	0.5	0.4	400 V ~ 3 ph	0.9	6.0	12.0	14.0	7	R 2"	343	90	200	249	95	120	12.5
SP(T) 08	1.05	0.75	400 V ~ 3 ph	1.8	11.0	18.0	21.0	7	Rp 2"	368	90	225	279	95	120	16.5

HONDA used water and wastewater pumps

Product description

The gasoline-powered Honda pumps are available for freshwater or for wastewater applications. The wastewater pumps can transport water with solids such as gravel up to a grain size of 31 mm without clogging the pump.

Benefits

- Compact and lightweight
- Gasoline-powered
- Powerful and efficient engines
- Low-oil protection provided
- Improved anti-vibration system
- Coil and impeller made from cast iron -> Long service life of pump guaranteed
- Installation at any angle (360° operation possible)
- Stable frame -> Secure protection, handle for transport



For pure clear water, we also offer self-priming garden pumps with automatic switches on request.

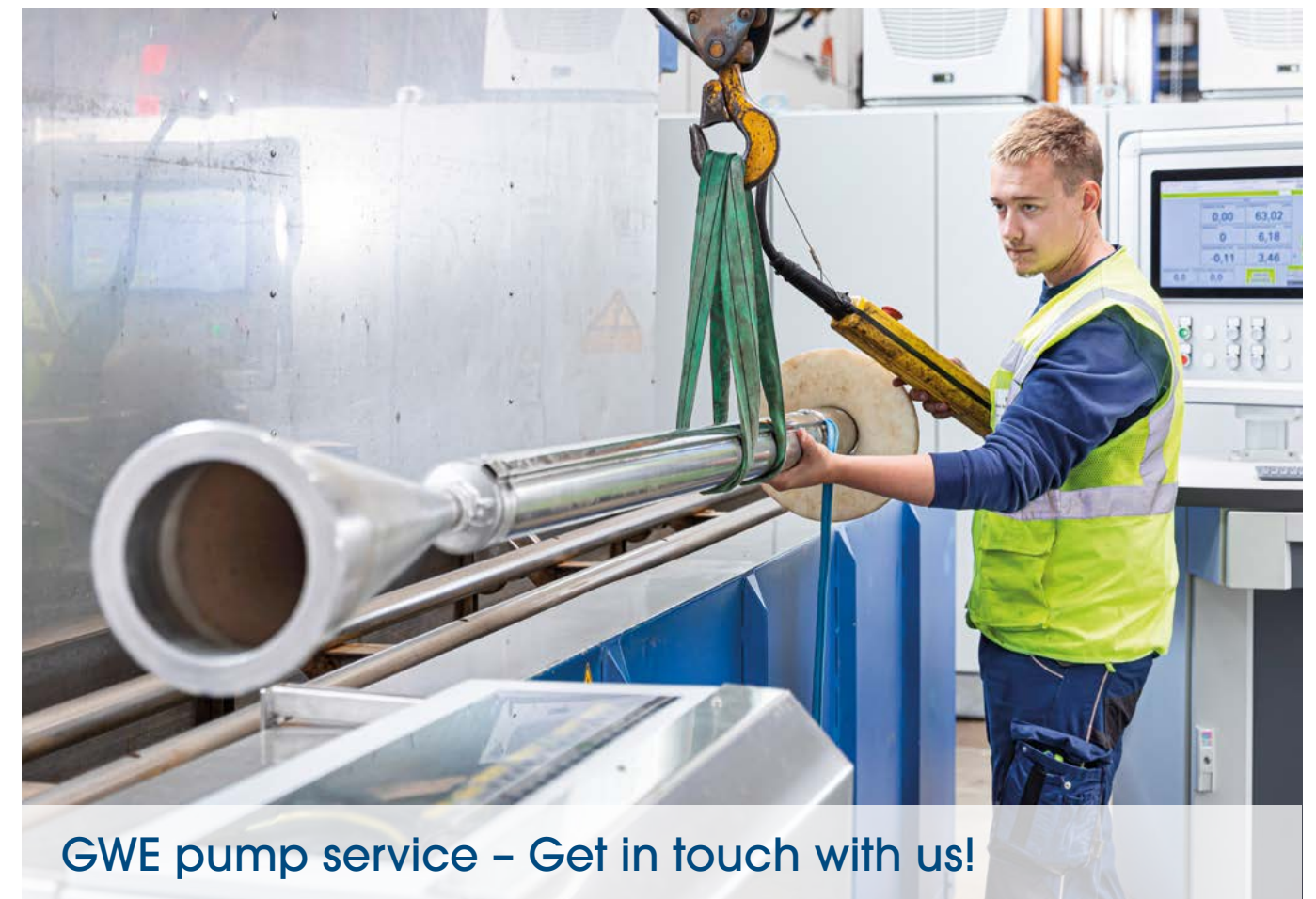

GWE pump service – Get in touch with us!

Technical data

	Freshwater pumps				Wastewater pumps		
	WX 10	WX 15	WH 15X	WH 20*	WT 20	WT 30	WT 40
Max. output (l/min)	120	280	370	450	700	1,200	1,600
Max. capacity (m³/h)	7.2	16.8	22.2	27.0	42.0	72.0	96.0
Input/output diameter mm/inch - thread type	25/1.0-PF	40/1.5-PF	40/1.5-PF	50/2.0-PF	50/2.0-PF	80/3.0-PF	100/4.0-PF
Max. total pump head (m)	37	40	40	50	26	25	25
Max. suction height (m)	8.0	8.0	8.0	8.0	8.0	8.0	8.0
Pumping pressure (bar)	3.7	4.0	4.0	5.0	2.6	2.5	2.5
Max. grain size (mm)**	5.7	5.7	3.0	3.0	24.0	28.0	31.0
Engine model	GX25	GXH50	GX120	GX160	GX160	GX270	GX390
Engine type	4-stroke OHC, 1 CYLINDER	4-stroke OHV***, 1 CYLINDER	4-stroke OHV***, 1 CYLINDER	4-stroke OHV***, 1 CYLINDER	4-stroke OHV***, 1 CYLINDER	4-stroke OHV***, 1 CYLINDER	4-stroke OHV***, 1 CYLINDER
Displacement (cm³)	25	49	118	163	163	270	389
Bore x stroke (mm)	35.0 x 26.0	41.8 x 36.0	60.0 x 42.0	68.0 x 45.0	68.0 x 45.0	77.0 x 58.0	88.0 x 64.0
Engine speed (rpm)	Max. 7,000	Max. 7,000	Max. 3,600	Max. 3,600	Max. 3,600	Max. 3,600	Max. 3,600
Nominal engine power (kW) (SAE J1349)	0.72	1.60	2.60	3.60	3.60	6.30	8.70

	Freshwater pumps				Wastewater pumps		
	WX 10	WX 15	WH 15X	WH 20*	WT 20	WT 30	WT 40
Cooling system	Air cooling circulating	Air cooling circulating	Air cooling circulating	Air cooling circulating	Air cooling circulating	Air cooling circulating	Air cooling circulating
Ignition system	Transistor	Transistor	Transistor	Transistor	Transistor magnetic ignition	Digital CDI	Digital CDI
Oil capacity (l)	0.08	0.25	0.56	0.58	0.58	1.10	1.10
Capacity of fuel tank (l)	0.53	0.77	2.00	3.10	3.10	5.30	6.10
Operating period at max. output (min)	54	54	90	90	90	90	90
Starting system	Pull-cord starter	Pull-cord starter	Pull-cord starter	Pull-cord starter	Pull-cord starter	Pull-cord starter	Pull-cord starter
Length (mm)	340	355	415	520	620	660	735
Width (mm)	220	275	360	400	460	495	535
Height (mm)	295	375	415	460	465	515	565
Dry weight (kg)	6.1	9.1	22	27	47	61	78
Sound pressure level at the operator's ear - dB(A) (98/37/EC, 2006/42/EC)	87	90	87	91	92	95	96
Guaranteed sound power level (2000/14/EC, 2005/88/EC)	100	104	104	106	106	110	112

Freshwater pumps

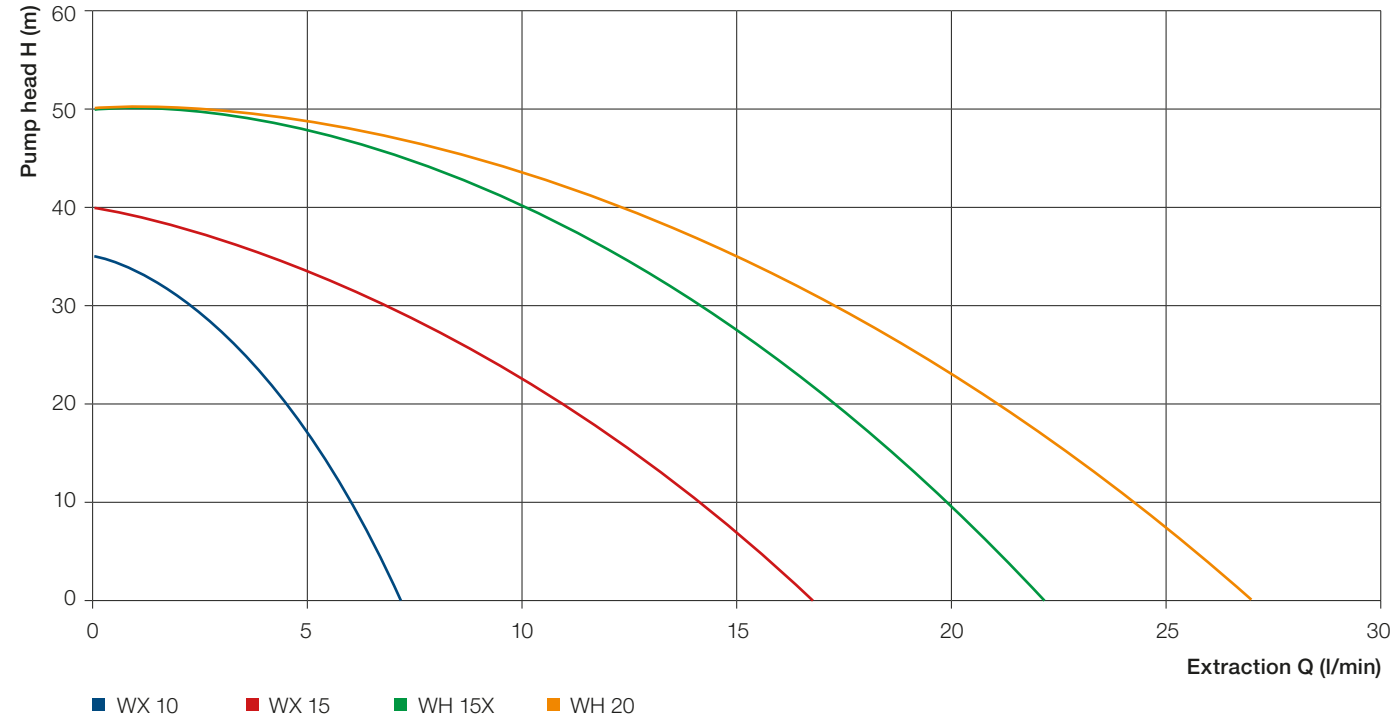

Hydraulic data for freshwater pumps

WX 10		WX 15		WH 15X		WH 20	
Q	H	Q	H	Q	H	Q	H
(m³/h)	(m)	(m³/h)	(m)	(m³/h)	(m)	(m³/h)	(m)
7.2	0	16.8	0	22.2	0	27	0
4.5	20	11.0	20	17.3	20	21.1	20
0	35	0	40	0	50	0	50

Wastewater pumps

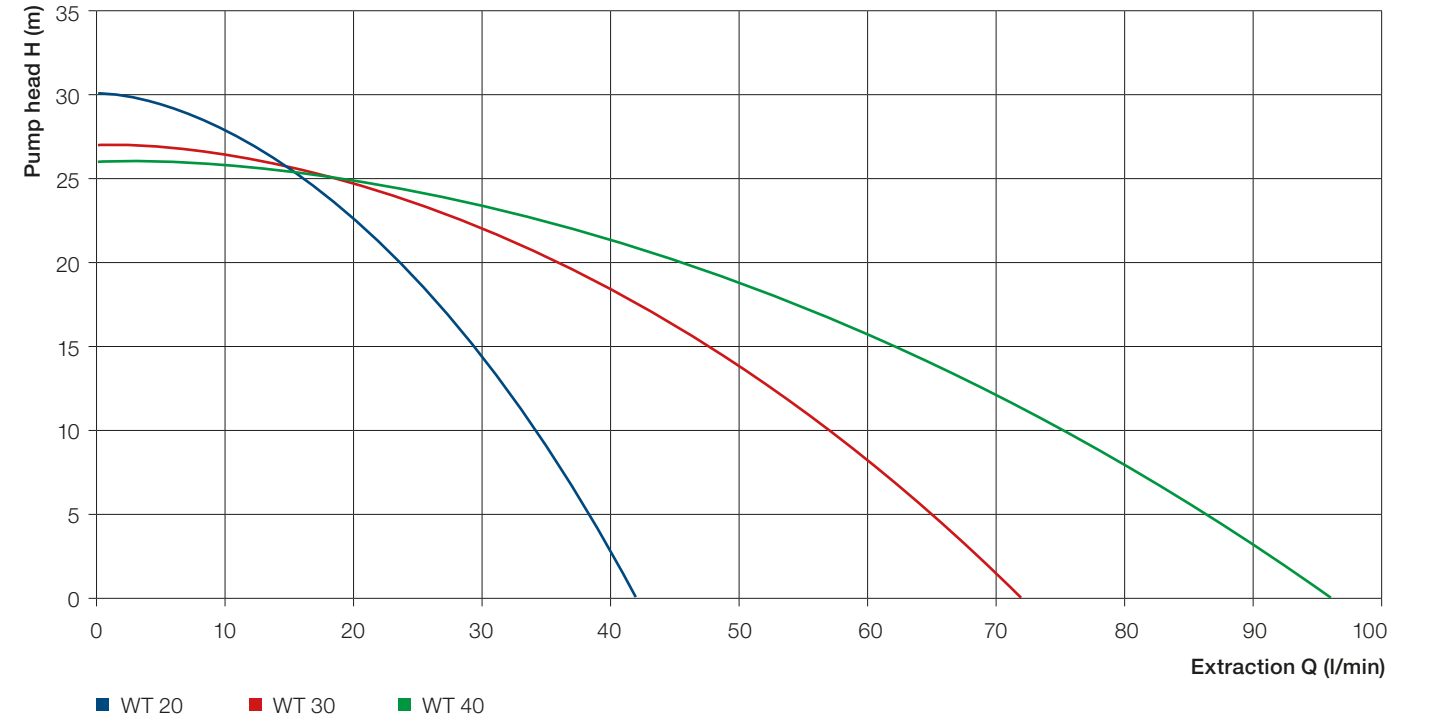

Hydraulic data for wastewater pumps

WT 20		WT 30		WT 40	
Q	H	Q	H	Q	H
(m³/h)	(m)	(m³/h)	(m)	(m³/h)	(m)
42	0	72	0	96	0
23.7	20	36.3	20	45.8	20
0	30	0	27	0	26

GWE Monitoring & Control System (MCS) – Managing water intelligently

Product description

With the new MCS, it is easy for you to manage your wells, pump stations, water reservoirs and irrigation intelligently. The Monitoring & Control System enables you to monitor and control your installation using an app from wherever you are – an easy solution that offers high quality and reliable operation.

Scope of service

- Compact **smart** all-in-one solution for your well
- **Monitoring** of well parameters
- **Error diagnosis with remote alarm system**, remote control of pump and plant engineering
- Integrated LTE modem, VPN router and LAN interface
- High-performance quad-core processors
- Long-term data buffering
- Can be used as a full-fledged SPS
- Can be coupled with any available frequency converter
- Top hat rail installation - can be used in any control box



Benefits

- Remote control of pump and remote diagnosis of entire well
- Remote programming via internal VPN router
- Interstation communication using CODESYS
- Extremely large storage capacity
- No external SPS required
- No conversion of an existing SPS required
- External I/Os can be extended flexibly
- Powerful and future-oriented
- Stable data transmission, flexibility at point of operation
- Lightweight and compact

Technical data

Main module

Processor	Quad-core
Dimensions (Width x Height x Depth in mm)	123 x 142 x 50
Data transmission	LTE or DSL (automatic alternative path switching)
Interfaces	2 x LAN, WLAN, RS485 (Modbus RTU), RS232 (Serial), USB
Number of digital inputs	8
Installation	Top hat rail
Integrated SPS function	CODESYS V3.5 (according to IEC 61131-3)
Supply voltage	24 V
Operating temperature	-10 °C to +55 °C

Optional modules

Analog input module	4 x analog inputs (4-20 mA)
Digital output module	16 x digital outputs
Temperature module	4 x PT100 inputs

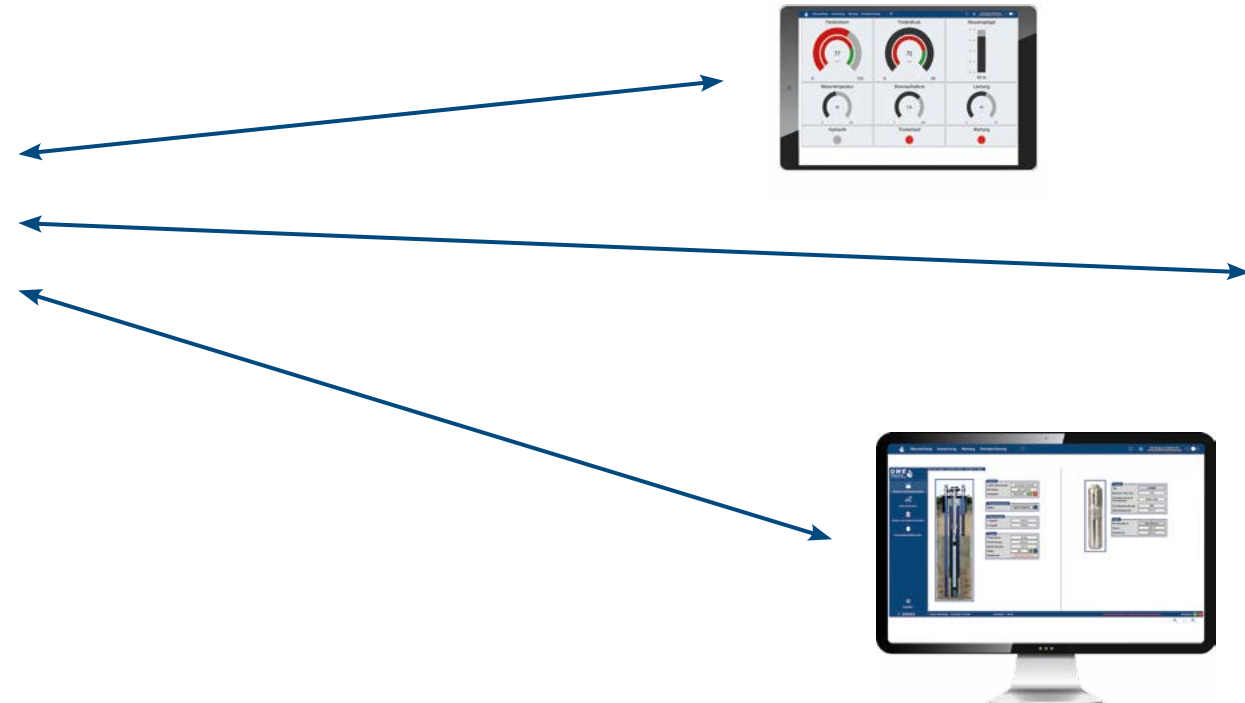

Accessories



Pressure tanks

			
Membrane pressure tank Type Airfix	Membrane pressure tank Type Wellmate	Pressure tank 4-6-10 bar	Fluid level pipes with water gauge valves
8–24 l	55–435 l	150–3,000 l in 4, 6 or 10 bar	Depending on tank content
Steel, varnished	Fiberglass	Galvanized, on stand	Brass, Plexiglass



Pressure control unit, pressure switch and pressure sensors

			
Pressure control unit	Pressure switch, 3-pole	Pressure gauge with brass Bourdon tube	Pressure sensor
1–16 bar or 0.5–8 bar	3-pole: up to 16 bar	0–6 bar 0–10 bar 0–16 bar 0–25 bar	4–20 mA 0–10/16 bar
Standard version: Brass	Plastic/metal	Optional: Pressure gauge valve with rotatable spigot socket for 1/2" pressure gauge in brass	Stainless steel

Motor protection devices

	
Motor protection switch MSM	PT 100
2.5–16 A	Different cable lengths
Optional: ISO housing, protection class IP 55	Stainless steel/Santoprene

Cooling jackets

		---
Cooling jacket with tensioning straps, spacer ring and sealing	Support clamps (set), screen basket with tensioning strap	Centering device for 4", 6" and 8" submersible motors
Depending on pump type, 4" to 8"	Depending on pump type, 4" to 8"	Depending on pump type, 4" to 8"
Jacket: 1.4301 Spacer ring: 1.4301 Sealing: Rubber	Straps: 1.4301 Basket: 1.4301	1.4401



Switch boxes and automatic switches

		
SPPDL switch box for automatic pressure-dependent on and off switching of pumps (without dry-run protection)	SPPKZ switch box for automatic pressure-dependent on and off switching of pumps (with dry-run protection)	Pressure switch, 1-pole
Up to 7.5 kW	Up to 7.5 kW	1-pole: up to 32 bar (without motor protection relay)
Impact-resistant plastic switch box	Impact-resistant plastic switch box	Plastic/metal

Electrode level relays, electrodes and electrode cables

		
Electrode level relay (dry-run protection) with and without insulation housing	Electrode EL-S for screw connection	Electrode cable ELKA
Dimensions	Temperature range 0 °C – +60 °C	1x 1.5 mm ² , max. cable length per electrode 100 m
Plastic	Dipped electrode made of stainless steel with plastic housing	Certified for use with drinking water



Pump cables

	
Cable certified for use with drinking water, cast with cable coupling for 4" Grundfos motors	Submersible cable (certified for use with drinking water, blue)
4 x 1.5 mm ² 10–50 m	3 x 1.5 – 3 x 6 mm ² 4 x 1.5 – 4 x 70 mm ²
Certified for use with drinking water	Certified for use with drinking water





Float switch, ballast weight and stainless steel rope (other accessories)

		
Float switch	Ballast weight	Stainless steel rope and stainless steel rope clamps
Different cable lengths and functions	For float switch	Nominal diameter: 2–5 mm
Rubber cable, plastic	Plastic	1.4401

Cable connectors

		
Shrink-on sleeve set comprising crimp connector, short pieces and long piece	Cast resin sleeve	Fastening belt with dovetail perforation
3 / 4 x 1.5 – 3 / 4 x 16 mm ² 1 x 35–120 mm ²	M0 to M4	Length: up to 5 m Thickness: 5 mm Width: 24 mm
Shrink-on sleeve with adhesive, aluminum crimp connector	Cast resin, plastic	Semperit E628 in accordance with Elastomer Directive (certified for use with drinking water)

Valves and ball drives

			
Brass aeration valve P3 (remove or drill into VR of pump)	Brass sleeve shut-off valve	Ball valve (with and without discharge)	Brass foot valve with suction strainer
Available in 1", 1 1/4", 1 1/2" and 2" (Spare valve for P3)	Available in 1/2", 3/4", 1", 1 1/4", 1 1/2", 2", 2 1/2", 3" and 4"	Available in 3/4", 1", 1 1/4", 1 1/2" and 2"	Available in 3/4", 1", 1 1/4", and 1 1/2"
Brass	Brass	Hot-pressed brass, matt chrome-plated	Brass



6. Grouting material and sealing clays

Product overviews	152
Specialist knowledge	156
Sealing clays	158
Bentonite-clay slurry	166









Access current information about
the product area online

Sealing clays water well construction

	Mikolit® 00	Mikolit® 300	Compactonit® 10/80	Quellon® S	Compactonit® 10/200	Mikolit® 300M	Quellon® WP	Quellon® HD
Product								
Product type	Clay pellets with low swelling capacity	Clay pellets with moderate swelling capacity	Clay pellets with moderate swelling capacity	Clay pellets with high swelling capacity	Clay pellets with high swelling capacity	Clay pellets with moderate swelling capacity	Clay pellets with high swelling capacity	Clay pellets with high swelling capacity
						Marked	Marked	Marked and weighted
Application	Annular gap sealing for large-caliber drilling	Annular gap sealing for dimensionally stable dry drilling	Annular gap sealing for dimensionally stable dry drilling	Annular gap sealing for flush drilling	Annular gap sealing for flush drilling	Annular gap sealing for dimensionally stable dry drilling with traceability in magnetic log	Annular gap sealing for flush drilling with traceability in gamma log	Annular gap sealing for flush drilling with traceability in magnetic logging for large installation depths
Product benefits	Value for money	Value for money	Value for money	High leak tightness	High leak tightness	Value for money	High leak tightness	High leak tightness
	Clay pellet	Leak tightness	Leak tightness			Good traceability	Good traceability	Good traceability

Bentonite-clay slurries well construction/geothermal energy

	Dämmer	Troptogel® B	Troptogel® C	Füllbinder® L-HS	GeoTherm® Light	GeoTherm® 2.0	ThermoSeal® M
Product	Well construction			Geothermal energy			
							
Product type	Dry mortar	Ready-mix product	Ready-mix product	Dry mortar	Dry mortar	Ready-mix product	Clay pellets
						Thermally improved	Marked
Application	Sealing mass for backfilling underground cavities	Annular gap sealing of wells and groundwater measuring points with high leak tightness requirements	Annular gap sealing of wells and groundwater measuring points with high leak tightness requirements and requirement of traceability in gamma log	Annular gap sealing for geothermal probes with frost and dew resistance	Annular gap sealing for geothermal probes with good heat conductivity and frost and dew resistance	Annular gap sealing for geothermal probes with very good heat conductivity and frost and dew resistance	Annular gap sealing for geothermal probes in difficult geology with good thermal conductivity, frost and dew resistance with traceability in magnetic log
Product benefits	Value for money	Leak tightness	Leak tightness/Yield	Value for money	Value for money	Thermal conductivity	Traceability
		Yield	Good traceability		Frost and dew resistance	Frost and dew resistance	Frost and dew resistance

Grouting material and sealing clays in water well construction

General

The construction of boreholes for the extraction, observation and exploration of groundwater deposits also generally involves drilling in cohesive sediments which pose hydraulic barriers in their undisturbed structure. They separate groundwater deposits of differing qualities and mineralization levels and prevent anthropogenically polluted water from penetrating into low-lying aquifers. During the dismantling or demolition of boreholes for wells or measuring points, it is therefore generally necessary to traceably restore the previously perforated clay layers by installing suitable sealing materials.

Tasks of sealing material in well construction

Sealing materials in well construction are subject to high quality requirements. The following requirements must be fulfilled:

- Effective sealing in installed condition – Leak tightness of the system
- Hygienic safety for drinking water
- Chemically and microbiologically inert
- Secure strategic positioning
- Traceable in geophysical borehole measurements

Types and characteristics of sealing materials

The installation location for sealing materials when constructing wells or groundwater measuring points is the annular gap between the well casing and the borehole wall. In general, sealing products in water well construction are subdivided into poured sealing clays capable of swelling and plastic, pumpable sealing masses.

Sealing clays vary in their shape, swelling capacity, structural stability, intrinsic density and geophysical traceability. Installation in the borehole is generally carried out in the form of a loose filling by lowering into the drilling fluid or water. Control sounding is used to document the placement of the sealing material at the correct depth. Limits are posed by the borehole depth and annular gap geometry.

Sealing masses are ready-mixes of clay and binding agent that are mixed with water to form stable slurries. Using the tremie method, they can be installed securely up to great depths and can also fill in complex or narrow annular gaps.

Sealing clays/clay pellets

For the construction of seals in water well construction, clay products in pellet form with a high swelling capacity have proven particularly effective. They are predominantly composed of the clay mineral bentonite and have a cylindrical shape with uniform, compact surface.

The decisive advantage compared with materials with a low swelling capacity made of kaolinitic/illitic clays lies in their capacity of volumetric expansion and buildup of compressive swelling stress. This establishes a friction-locked connection of the clay sealing to border areas (extension pipes/borehole wall), which prevents leaks at the edges and achieves excellent system tightness. The pellet shape enables good, constant lowering speeds and delayed swelling behavior, thereby guaranteeing secure positioning in the annular gap.

Sealing clays with swelling capacities of < 30% when positioned freely under water, which mean they are smaller than the pore volume of the clay filling, should only be used for sealings in water well construction in limited cases. It cannot be excluded here that continuous pores may remain in the clay filling, particularly on the border areas (extension pipes/borehole wall), which result in increased permeability levels. Large hydraulic gradients then cause erosion, which leads to the total breakdown of the barriers and causes the filling materials to shift above the clay sealing.

Sufficiently strong borehole sealings with low swelling-capacity clay can only be achieved in boreholes of $\varnothing > 400$ mm or larger due to the sufficiently high vertical loads exerted by the covering. For smaller borehole/annular gap cross sections, we recommend exclusively using sealing materials that contain bentonite for the reasons outlined above.

Apart from sufficient compressive swelling stress and minimized permeability coefficients, the other quality criteria for sealing clays include:

- Lowering behavior/security of installation
- Shaping
- Structural stability
- Traceability in geophysical borehole measurements

Clay pellets have proven very effective compared to granulated products with regard to security of installation and structural stability. Smooth, compact surfaces delay the swelling process when lowering into the borehole and thus reduce the risk that bridges/packages will form along the way down.

Thanks to special mineral aggregates, products can be delivered with particular individual characteristics, for example increased intrinsic density/lowering speed, with magnetic properties and increased inherent radiation, to ensure traceability during well control measurements.

Bentonite-clay slurries

Apart from the use of clay products to seal wells and groundwater measuring points, ready-mix products have proven effective and become established in the production of pumpable sealing slurries for borehole seals.

They are primarily composed of:

- Hydraulic binding agent
- Clay with low swelling capacity (kaolinite)
- Clay with high swelling capacity (bentonite)
- Special mineral additives in case of more extensive requirements

In principle, clay-cement slurries can be used for all sealing activities in well construction, i.e. both for simple well demolitions as well as for annular gap sealing in groundwater measuring points. By using established insertion methods, sealings can be produced reliably at great depths.

As with clay products, special mineral admixtures are also available for pumpable sealings, which for example feature an enhanced natural gamma activity. This achieves improved traceability in geophysical borehole measurements. Particularly for subsequent injection of annular gaps, reliable geophysical borehole measurements are an important foundation for quality assessment of completed rehabilitation measures.

Pumpable sealing masses also offer benefits in the construction of wells for extracting geothermal energy. Their flowable consistency enables secure complete covering of installed probe pipes, bends and spares while at the same time restoring hydraulic barriers that were drilled through. Depending on the requirements, simple Dämmer slurries or filling masses with increased thermal conductivity are used.

Pumpable sealing masses for qualified grouting material and sealing clays of wells, groundwater measuring points and geothermal probes should feature the following characteristics:

- Absolute volumetric resistance
- kf values < 10^{-10} m/s
- High system tightness
- No temperature increase during the binding process
- Sedimentation stability
- High resistance to concrete-aggressive waters
- Filter stability in permeable border areas
- Localizable in geophysical borehole measurements
- Hygienic safety for drinking water

For the construction of sealing masses, high-speed mixers have proven effective, which colloidally disintegrate the binding agent/clay mixture to form clump-free, stable slurries with efficient use of materials. The mixer capacity must be adapted to the size of the required sealing activity in order to produce adequate quantities of slurry in the available time window. Requirements for key slurry figures such as Marsh funnel time for flowing out, density and processing times must be observed and documented.

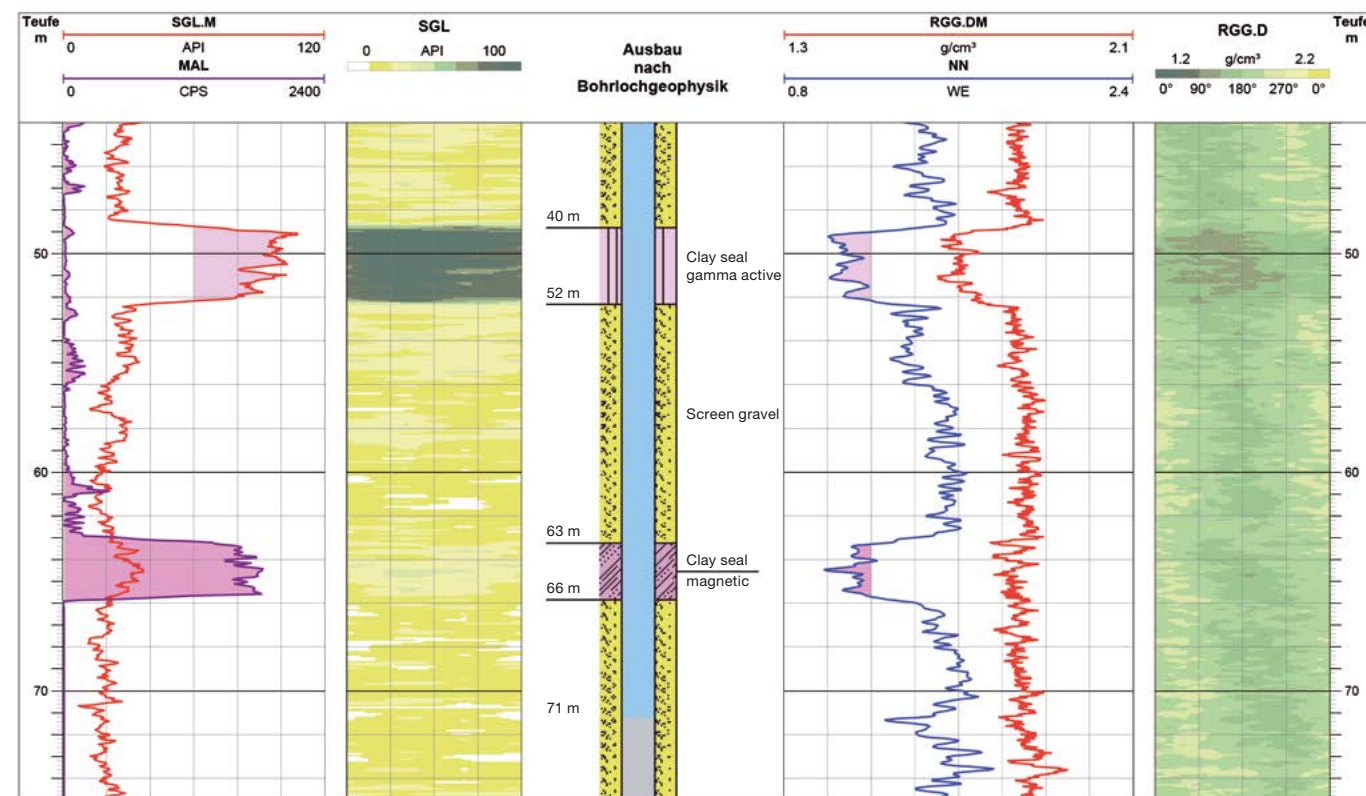

Traceability of annular gap backfill in geophysical borehole measurements

Mikolit® 00

Product description

Sealing clay with low swelling capacity in pellet form. Preferred use in large-caliber boreholes (> 400 mm), for demolition and borehole backfilling.



Product characteristics

Product type	Clay pellets	
Dimensions (length)	7-12	mm
Dimensions (diameter)	8	mm
Compressive swelling stress	0.0035	N/mm ²
Radiation activity	Approx. 80	API
Bulk density	1.1	g/cm ³
Permeability coefficient	< 10 ⁻¹⁰	m/s
Lowering speeds	21	m/min

Areas of application and product characteristics

Due to the limited swelling capacity, good seals are achieved in moderate annular gaps and leaks at the edges are securely prevented. The slowly onsetting swelling process offers benefits in the use of mechanical dry drilling. Auxiliary casings that have been filled over can be dismantled without adherence. Even under large hydraulic gradients, the water permeability status is ensured without a doubt.

Determination of requirements

1. Backfilling (entire borehole):

Diameter borehole² dm x 8.64 → Mikolit® 00 kg/m

2. Annual gap filling:

Diameter borehole² dm - pipe diameter² dm) x 8.64 → Mikolit® 00 kg/m

Packaging

Mikolit® 00 is available for delivery in 25 kg plastic sacks and 1 t BigBags.

Mikolit® 300

Product description

Moderate swelling capacity bentonite-based sealing clay in pellet form. Preferred use in wells and measurement points excavated using cased dry drilling methods.



Product characteristics

Product type	Clay pellets	
Dimensions (length)	7-12	mm
Dimensions (diameter)	8	mm
Compressive swelling stress	0.009	N/mm ²
Radiation activity	Approx. 80	API
Bulk density	1.1	g/cm ³
Permeability coefficient	< 10 ⁻¹¹	m/s
Lowering speeds	21	m/min

Areas of application and product characteristics

Due to the limited swelling capacity, good seals are achieved in moderate annular gaps and leaks at the edges are securely prevented. The slowly onsetting swelling process offers benefits in the use of mechanical dry drilling. Auxiliary casings that have been filled over can be dismantled without adherence. Even under large hydraulic gradients, the water permeability status is ensured without a doubt.

Determination of requirements

1. Backfilling (entire borehole):

Diameter borehole² dm x 8.64 → Mikolit® 300 kg/m

2. Annual gap filling:

Diameter borehole² dm - pipe diameter² dm) x 8.64 → Mikolit® 300 kg/m

Packaging

Mikolit® 300 is available for delivery in 25 kg plastic sacks and 1 t BigBags.

Mikolit® 300 M

Product description

Moderate swelling capacity bentonite-based sealing clay in pellet form with magnetite filler. Preferred use in wells and measurement points excavated using cased dry drilling methods.



Product characteristics

Product type	Clay pellets	
Dimensions (length)	5–10	mm
Dimensions (diameter)	8	mm
Compressive swelling stress	0.0056	N/mm ²
Radiation activity	Approx. 50	API
Bulk density	1.3	g/cm ³
Permeability coefficient	< 2.3 x 10 ⁻¹¹	m/s
Lowering speeds	25	m/min

Areas of application and product characteristics

Due to the swelling capacity, good seals are achieved in moderate annular gaps and leaks at the edges are securely prevented. The slowly onsetting swelling process offers benefits in the use of mechanical dry drilling. Auxiliary casings that have been filled over can be dismantled without adherence. Even under large hydraulic gradients, the water permeability status is ensured without a doubt. Grouting material and sealing clays made of Mikolit® 300 M are traceable in magnetic logging for geophysical borehole construction check measurements.

Packaging

Mikolit® 300 M is available for delivery in 25 kg plastic sacks.

Determination of requirements

1. Backfilling (entire borehole):

Diameter borehole² dm x 10.2 → Material requirement kg/m

2. Annual gap filling:

(Diameter borehole² dm - pipe diameter² dm) x 10.2
→ Material requirement kg/m

Compactonit® 10/80

Product description

Moderate swelling capacity bentonite-based sealing clay in pellet form. Preferred use in wells and measurement points excavated using cased dry drilling methods.



Product characteristics

Product type	Clay pellets, cylindrical	
Dimensions (length/diameter)	6–15/10	mm
Compressive swelling stress (after 35 days)	0.02	N/mm ²
Permeability coefficient (k _f value)	5 x 10 ⁻¹¹	m/s
Bulk density	1.25	g/cm ³
Radiation activity	Approx. 50	API
Magnetic susceptibility	Cannot be verified in magnetic logging	
Lowering speeds	18	m/min
Water content	< 18	%
Undersize / oversize	< 1/0	%
Carbonate content	< 5	%
Structural stability		
Mass loss - lowering phase	< 2	%
Mass loss - installed condition	6	%
Penetration resistance - installed condition	0.06	N/mm ²

Areas of application and product characteristics

Due to the swelling capacity, effective seals are achieved in moderate annular gaps and leaks at the edges are securely prevented. The slowly onsetting swelling process offers benefits in the use of mechanical dry drilling. Auxiliary casings that have been filled over can be dismantled without adherence. Even under large hydraulic gradients, the impermeability to water is ensured without a doubt.

Packaging

Compactonit 10/80® is available for delivery in 25 kg plastic sacks and 1 t BigBags.

Determination of requirements

1. Backfilling (entire borehole):

Diameter borehole² dm x 9.82 → Material requirement kg/m

2. Annual gap filling:

(Diameter borehole² dm - pipe diameter² dm) x 9.82
→ Material requirement kg/m

Compactonit® 10/200

Product description

High swelling capacity bentonite-based sealing clay in pellet form. Universal use in wells and measurement points excavated using flush drilling methods.



Product characteristics

Product type	Clay pellets, cylindrical	
Dimensions (length/diameter)	6–15/10	mm
Compressive swelling stress (after 35 days)	0.04	N/mm ²
Permeability coefficient (k _f value)	1 x 10 ⁻¹¹	m/s
Bulk density	1.18	g/cm ³
Radiation activity	Approx. 50	API
Magnetic susceptibility	Cannot be verified in magnetic logging	
Lowering speeds	18	m/min
Water content	< 18	%
Undersize / oversize	< 1/0	%
Carbonate content	< 5	%
Structural stability		
Mass loss - lowering phase	< 2	%
Mass loss - installed condition	6	%
Penetration resistance - installed condition	0.31	N/mm ²

Areas of application and product characteristics

The high swelling capacity of Compactonit® 10/200 clay pellets ensures a friction-locked connection of the seal to border areas in the annular gap of the well even with a low-load cover without external compaction. Sealings made of Compactonit® 10/200 also feature a high safety reserve, which also securely seals borehole expansions that are difficult to fill at an expansion of up to 45%. The smooth surfaces and high structural stability of Compactonit® 10/200 clay pellets delay the swelling process and enable secure positioning of the pellets even in sealings at deeper levels. Grouting material and sealing clays made of Compactonit® 10/200 are traceable in geophysical borehole construction check measurements using gamma-gamma measurement.

Packaging

Compactonit® 10/200 is available for delivery in 25 kg plastic sacks and BigBags.

Determination of requirements

1. Backfilling (entire borehole):

Diameter borehole² dm x 9.26 → Material requirement kg/m

2. Annual gap filling:

(Diameter borehole² dm - pipe diameter² dm) x 9.26 → Material requirement kg/m

Quellon® S

Product description

High swelling capacity bentonite-based sealing clay in pellet form. Universal use in wells and measurement points excavated using flush drilling methods.



Product characteristics

Product type	Clay pellets, cylindrical	
Dimensions (length/diameter)	7–12/8	mm
Compressive swelling stress (after 35 days)	n/a	N/mm ²
Permeability coefficient (k _f value)	< 3 x 10 ⁻¹¹	m/s
Bulk density	1.20	g/cm ³
Radiation activity	approx. 50	API
Magnetic susceptibility	Cannot be verified in magnetic logging	
Lowering speeds	22.5	m/min
Water content	< 18	%
Undersize / oversize	< 1/0	%
Carbonate content	≤ 2	%
Structural stability		
Mass loss - lowering phase	< 1	%
Mass loss - installed condition	7.3	%
Penetration resistance - installed condition	N/a	N/mm ²

Areas of application and product characteristics

Quellon® S clay pellets feature a very high swelling capacity. Border areas in the annular gap of the well are sealed securely and friction-locked, even with a low-load cover without external compaction. Borehole expansions that are difficult to fill in can also be sealed reliably. Furthermore, Quellon® S clay pellets exhibit a considerable swelling capacity even during applications in brackish water.

The compact shape and smooth surfaces of the Quellon® S clay pellets enable a high lowering speed. Together with their high structural stability, this enables secure positioning of the pellets even in sealings at deeper levels.

Packaging

Quellon® S is available for delivery in 25 kg plastic sacks and 1 t BigBags.

Determination of requirements

1. Backfilling (entire borehole):

Diameter borehole² dm x 9.42 → Material requirement kg/m

2. Annual gap filling:

(Diameter borehole² dm - pipe diameter² dm) x 9.42 → Material requirement kg/m

Quellon® HD

Product description

High swelling capacity bentonite-based sealing clay in pellet form with magnetite filler. Preferred use in deep wells and measurement points excavated using flush drilling methods.



Product characteristics

Product type	Clay pellets, cylindrical	
Dimensions (length/diameter)	6–15/10	mm
Compressive swelling stress (after 35 days)	0.05	N/mm ²
Permeability coefficient (k _f value)	2 x 10 ⁻¹¹	m/s
Bulk density	1.35	g/cm ³
Radiation activity	approx. 50	API
Magnetic susceptibility	Cannot be verified in magnetic logging	
Lowering speeds	25	m/min
Water content	< 18	%
Undersize / oversize	< 1/0	%
Carbonate content	< 5	%
Structural stability		
Mass loss - lowering phase	< 2	%
Mass loss - installed condition	6	%
Penetration resistance - installed condition	N/A	N/mm ²

Areas of application and product characteristics

The high specific weight of the pellets causes them to sink rapidly in water/drilling fluid, which achieves secure, exact positioning of the pellets even in deep wells and measurement points. Smooth surfaces and the high structural stability of Quellon® HD pellets delay the swelling effect and prevent them from breaking apart on the way down. The very good swelling capacity ensures a friction-locked connection of the Quellon® HD sealing to border areas (bore hole wall/extension tube) without additional compaction from the outside. Grouting material and sealing clays made of Quellon® HD are traceable in magnetic logging for geophysical borehole measurements.

Packaging

Quellon® HD is available for delivery in 25 kg plastic sacks and 1 t BigBags.

Determination of requirements

1. Backfilling (entire borehole):

Diameter borehole² dm x 10.6 → Material requirement kg/m

2. Annual gap filling:

(Diameter borehole² dm - pipe diameter² dm) x 10.6 → Material requirement kg/m

Quellon® WP

Product description

High swelling capacity bentonite-based sealing clay in pellet form with natural inherent gamma radiation. Preferred use in wells and measurement points excavated using flush drilling methods.



Product characteristics

Product type	Clay pellets, cylindrical	
Dimensions (length/diameter)	6–15/10	mm
Compressive swelling stress (after 35 days)	0.04	N/mm ²
Permeability coefficient (k _f value)	1 x 10 ⁻¹¹	m/s
Bulk density	1.18	g/cm ³
Radiation activity	> 100	API
Magnetic susceptibility	Cannot be verified in magnetic logging	
Lowering speeds	18	m/min
Water content	< 18	%
Undersize / oversize	< 1/0	%
Carbonate content	< 5	%
Structural stability		
Mass loss - lowering phase	< 2	%
Mass loss - installed condition	6	%
Penetration resistance - installed condition	0.31	N/mm ²

Areas of application and product characteristics

Grouting material and sealing clays made of Quellon® WP feature good traceability in construction check measurements with gamma logging thanks to their enhanced natural gamma radiation. The very good swelling capacity ensures a friction-locked connection of the Quellon® WP sealing to border areas (bore hole wall/extension tube) without additional compaction from the outside. Quellon® WP seals feature a high safety reserve. Their swelling also securely seals borehole expansions that are difficult to fill at an expansion of up to 45%. Smooth surfaces and the high structural stability of Quellon® WP pellets delay the swelling effect and prevent them from breaking apart on the way down.

Packaging

Quellon® WP is available for delivery in 25 kg plastic sacks and 1 t BigBags.

Determination of requirements

1. Backfilling (entire borehole):

Diameter borehole² dm x 9.26 → Material requirement kg/m

2. Annual gap filling:

(Diameter borehole² dm - pipe diameter² dm) x 9.26 → Material requirement kg/m

Dämmer

Product description

Construction material made of hydraulic binding agent and clay-based, inert rock powder for filling underground cavities of all kinds.



Product characteristics

Dämmer sealings enable cavity-free, volume-resistant filling of underground cavities. They can be constructed with all common site mixers. Thanks to their flowable consistency,

cavities can be filled up to a horizontal distance of several hundred meters. Dämmer is classified as hygienically safe for drinking water.

Recipe

Yield		Per 25 kg sack	
	847 kg	Dämmer	25 kg Dämmer
+	694 l	Water	+ 20.5 l Water
=	1,000 l	Injection mass	≈ 29.5 l Injection mass

1. Backfilling (entire borehole):

Diameter borehole² dm x 6.65 → Material requirement kg/m

2. Annual gap filling:

(Diameter borehole² dm - pipe diameter² dm) x 6.65
→ Material requirement kg/m

Key slurry figures

Key figure	Laboratory value	Unit
Water/solid value	0.82	
Marsh funnel time for flowing out	Ca. 45	s
Density	1.54	g/cm ³
Compressive strength (7 days)	0.6	N/mm ²
Compressive strength (28 days)	1.2	N/mm ²
k _f value	5 x 10 ⁻⁸	m/s

Packaging

Dämmer is available for delivery in 25 kg paper valve sacks.

Troptogel® B

Product description

Ready-mix made of clay minerals and hydraulic binding agents for the production of pumpable slurries for grouting material and sealing clays.



Product characteristics

Sealings made from Troptogel® B feature very high leak tightness and are especially suited for grouting material and sealing clays in the construction of wells and measurement points. Due to the optimally coordinated product components, no temperature increase results during the binding process, which could damage thermoplastic extension casings. The low density of Troptogel® B slurries also considerably reduces the

external compressive load on extension casings. The product is classified as hygienically safe for drinking water. Troptogel® exclusively contains bentonite with a high sulphate resistance pursuant to DIN EN 197-1 and DIN 1164-10. To ensure an optimal disintegration of the injection slurry, we recommend the use of colloidal mixers.

Recipe

Yield		Per 25 kg sack	
	520 kg	Troptogel® B	25 kg Troptogel® B
+	800 l	Water	+ 39 l Water
=	1,000 l	Injection mass	≈ 48 l Injection mass

1. Backfilling (entire borehole):

Diameter borehole² dm x 4.08 → Material requirement kg/m

2. Annual gap filling:

(Diameter borehole² dm - pipe diameter² dm) x 4.08
→ Material requirement kg/m

Key slurry figures

Key figure	Laboratory value	Unit
Water/solid value	1.54	
Marsh funnel time for flowing out	> 45	s
Density	1.33	g/cm ³
Water settling	< 1	%
Compressive strength (7 days)	1.8	N/mm ²
Compressive strength (28 days)	3.3	N/mm ²
k _f value	5 x 10 ⁻¹¹	m/s
Processing time	5	Hrs.

Packaging

Troptogel® B is available for delivery in 25 kg paper valve sacks.

Troptogel® C

Product description

Ready-mix made of clay minerals and hydraulic binding agents with increased natural gamma activity for the production of pumpable slurries for grouting material and sealing clays.



Product characteristics

Sealings made from Troptogel® C feature very high leak tightness. They are especially suited for grouting material and sealing clays in the construction of wells and measurement points that need to be inspected later using gamma measurement. Due to the optimally coordinated product components, no temperature increase results during the binding process, which could damage thermoplastic extension casings. The low

density of Troptogel® C slurries also considerably reduces the external compressive load on extension casings. The product is classified as hygienically safe for drinking water. Troptogel® C exclusively contains bentonite with a high sulphate resistance pursuant to DIN EN 197-1 and DIN 1164-10. To ensure an optimal disintegration of the injection slurry, we recommend the use of colloidal mixers.

Recipe

Yield		Per 25 kg sack	
590 kg Troptogel® C		25 kg Dämmmer	
+ 780 l Water		+ 33 l Water	
= 1,000 l Injection mass		≈ 42 l Injection mass	

Annual gap filling:
 (Diameter borehole² dm - pipe diameter² dm) x 4.5
 → Material requirement kg/m

Key slurry figures

Key figure	Laboratory value	Unit
Water/solid value	1.3	
Marsh funnel time for flowing out	> 50	s
Density	1.37	g/cm ³
Water settling	< 1	%
Compressive strength (7 days)	1.5	N/mm ²
Compressive strength (28 days)	3.5	N/mm ²
k _f value	3 x 10 ⁻¹¹	m/s
Processing time	5	Hrs.
Radiation activity	> 100	API

Packaging

Troptogel® C is available for delivery in 25 kg paper valve sacks.

Füllbinder® L-HS

Product description

Filling material for annular gap restoration of geothermal probes.



Product characteristics

Füllbinder® L-HS features low permeability coefficients on the magnitude of < 5 x 10⁻¹⁰ m/s and thus fulfils the requirements for restoration of perforated aquicludes. Füllbinder® L-HS

sealings are resistant to frost-dew changes according to in-house tests and feature increased chemical resistance, e.g. against groundwaters containing sulphates.

Recipe

Yield		Per 25 kg sack	
930 kg Füllbinder® L-HS		25 kg Füllbinder® L-HS	
+ 650 l Water		+ 17.5 l Water	
= 1,000 l Injection mass		= 27 l Injection mass	

Key slurry figures

Key figure	Laboratory value	Unit
Water/solid value	0.7	
Thermal conductivity	approx. 1	W(m K)
Marsh funnel time for flowing out	> 90	s
Density	1.59	g/cm ³
Compressive strength (7 days)	0.7	N/mm ²
Compressive strength (28 days)	3.4	N/mm ²
K _f value	1 x 10 ⁻¹⁰	m/s
Processing time	2	Hrs.

Packaging

Füllbinder® is available for delivery in 25 kg paper valve sacks.

GWE GeoTherm® Light

Product description

Filling material for annular gap restoration of geothermal probes.



Product characteristics

GWE GeoTherm® Light features very low permeability coefficients on the magnitude of $< 1 \times 10^{-10}$ m/s and thus securely fulfils the requirements for restoration of perforated aquicludes. GWE GeoTherm® Light sealings are resistant to frost-dew changes and feature increased chemical resistance, e.g. against groundwaters containing sulphates. Optimal flowing

properties result in complete displacement of the flushing material during injection. The low water settling of the filling material ensures a stable complete covering of the geothermal probe without defective spots. The high strength of the GWE GeoTherm® Light sealing mass ensures additional structural security of the probe.

Recipe

Yield		Per 25 kg sack	
830 kg	GeoTherm® Light	25 kg	GeoTherm® Light
+ 670 l	Water	+ 20 l	Water
= 1,000 l	Injection mass	≈ 30 l	Injection mass

Key slurry figures

Key figure	Laboratory value	Site value	Unit
Water/solid value	0.8		-
Thermal conductivity	Approx. 1		W/(m x K)
k_f value	1×10^{-10}		m/s
Processing time (20 °C)	2		h
Marsh funnel time for flowing out	60	≥ 50	s
Slurry density	1.51	≥ 1.48	kg/l
Sieve test (Marsh funnel)	Lump-free	Lump-free	-
Slurry temperature	20	≥ 5	°C
Sedimentation rate after 1 h	1.0	≤ 2.0	%
Sedimentation rate after 24 h	1.5	≤ 2.0	%

Compressive strength development

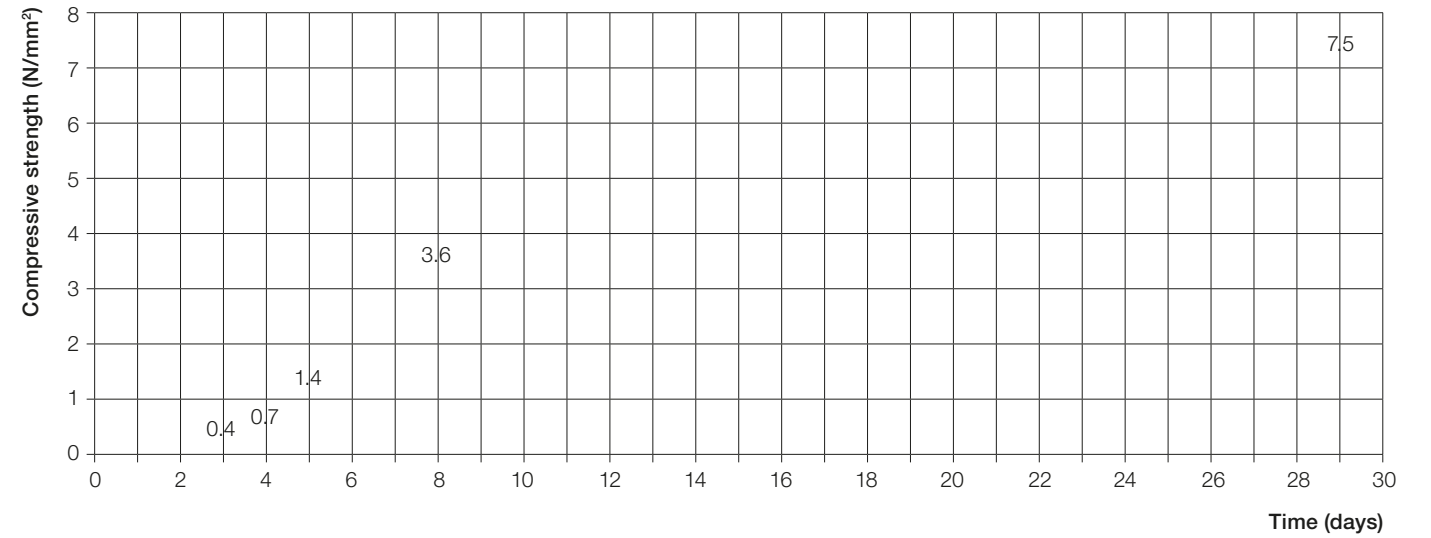

Probe preparation laboratory figures:

- 5 L bucket
- Dye swirler diameter 100 mm (aligned centrally)
- Speed 1,200 min⁻¹, mixing time 120 s
- Slurry quantity 3 l, Water/solid value: 0.8

Packaging and storage

GWE GeoTherm® Light is available for delivery in 25 kg paper valve sacks on fully shrink-wrapped Euro pallets. With dry storage, the product has a shelf life of at least 6 months.

GWE GeoTherm® 2.0

Product description

Filling material with high heat conductivity 2.0 W/(m K) for annular gap restoration of geothermal probes



Product characteristics

GWE GeoTherm®2.0 features very low permeability coefficients on the magnitude of $< 10^{-10}$ m/s and thus securely fulfils the requirements for restoration of perforated aquicludes. GWE GeoTherm® 2.0 sealings are resistant to frost-dew changes and feature increased chemical resistance, e.g. against groundwaters containing sulphates. Optimal flowing properties of the GeoTherm® 2.0 slurry result in complete displacement

of the flushing material during injection. The low water settling of the filling material ensures a stable complete covering of the geothermal probe without defective spots. The high strength of the GWE GeoTherm® 2.0 sealing mass ensures additional structural security of the probe.

Recipe

Yield		Per 25 kg sack	
810 kg	GeoTherm® 2.0	25 kg	GeoTherm® 2.0
+ 650 l	Water	+ 20 l	Water
= 1,000 l	Injection mass	≈ 29 l	Injection mass

Key slurry figures

Key figures	Laboratory value	Site value	Unit
Water/solid value	0.8		-
Thermal conductivity	2		W/(m x K)
k_f value	1×10^{-10}		m/s
Processing time (20 °C)	2		h
Marsh funnel time for flowing out	60	≥ 50	s
Slurry density	1.48	≥ 1.46	kg/l
Sieve test (Marsh funnel)	Lump-free	Lump-free	-
Slurry temperature	20	≥ 5	°C
Sedimentation rate after 1 h	1.0	≤ 2.0	%
Sedimentation rate after 24 h	1.5	≤ 2.0	%

Compressive strength development

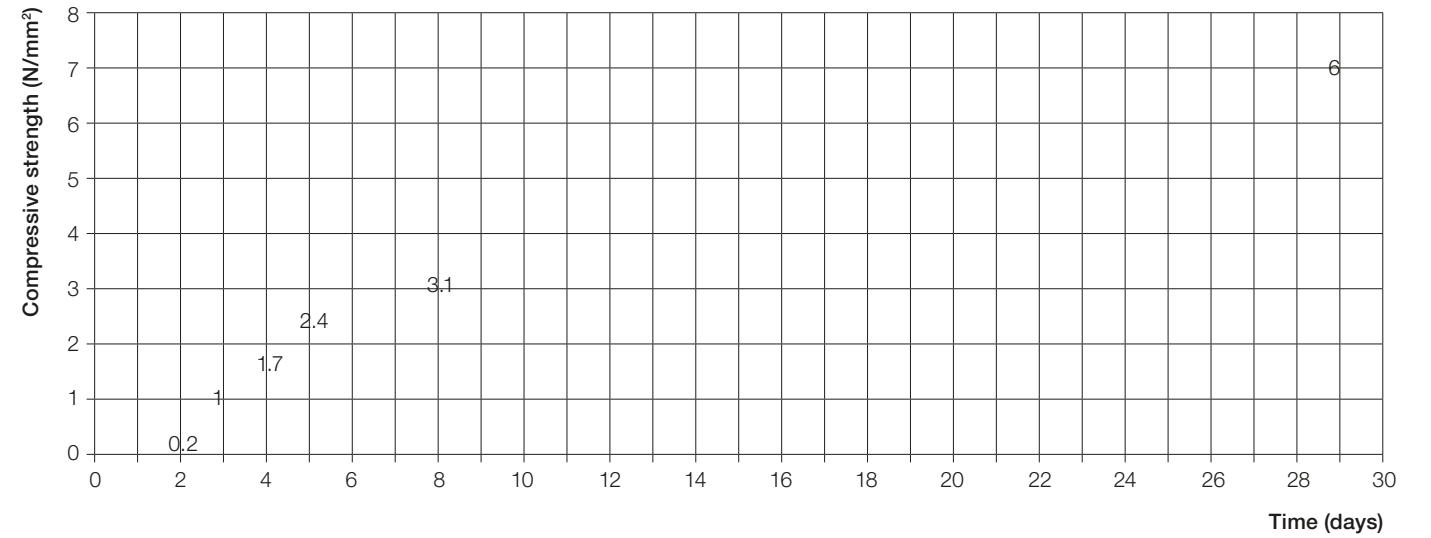

Probe preparation laboratory figures:

- 5 L bucket
- Dye swirler diameter 100 mm (aligned centrally)
- Speed 1,200 min⁻¹, mixing time 120 s
- Slurry quantity 3 l, Water/solid value: 0.8

Packaging and storage

GWE GeoTherm® 2.0 is available for delivery in 25 kg paper valve sacks on fully shrink-wrapped Euro pallets. With dry storage, the product has a shelf life of at least 6 months.

GWE ThermoSeal® M

Product description

High swelling capacity bentonite-based sealing clay in pellet form with magnetite filler for annular gap filling of geothermal probes.



Product characteristics

The material features permeability coefficients in the magnitude of 1×10^{-10} m/s. The swelling capacity of the clay pellets achieves a good connection to the geothermal probes and the surrounding geology. This results in high system tightness and low borehole resistance. In geothermal probes completed with Duplex or Simplex pipes, we recommend installing the material

with a clay pellet pump system. The necessary equipment can be rented from GWE. In contrast to fluid materials, GWE ThermoSeal® M can also be used to fill and seal fissured borehole areas. Grouting material and sealing clays made of GWE ThermoSeal® M are traceable via magnetic logging. The materials features high resistance to concrete-aggressive waters.

Technical data

Product type	Clay pellets	
Dimensions (length)	2–12	mm
Bulk density	1.1	g/cm ³
Permeability coefficient	$< 1 \times 10^{-10}$	m/s
Lowering speed (water)	25	m/min
Radiation activity	approx. 50	API
Thermal conductivity	Ca. 1.2	W/(m K)

Packaging

GWE ThermoSeal® M is available for delivery in 25 kg plastic sacks.



GWE flushing services – Get in touch with us!





7. Drilling fluids

Product overview	178
Specialist knowledge	180
Bentonite	182
Polymers	187



Access current information about
the product area online

Flushing agents

	Tixoton®	GWE PolyMix®	Hostapur OS	Viscopol® TLV	Viscopol® T	GWE PolyPile® HD-L	GWE PolyPile® HD	Viscopol® R (Antisol)
Product								
Product type	Active bentonite	Ready-mix product	Foaming agent	Technical CMC	Technical CMC	PHPA	PHPA	PAC
				Low viscosity	High viscosity	High viscosity	High viscosity	High viscosity
	Powder	Powder	Fluid	Powder	Powder	Fluid	Powder	Powder
Application	Basis of conservative drilling fluids	Easy and fast production of a universal drilling fluid	Regulates load-bearing capacity of air-based drilling fluids	Regulates filtration and flow characteristics of drilling fluids with high solid content	Regulates filtration and flow characteristics of drilling fluids with low solid content	Regulates filtration and flow characteristics of drilling fluids with low solid content	Regulates filtration and flow characteristics of drilling fluids with low solid content	Regulates filtration and flow characteristics of drilling fluids with low solid content
Product benefits	Value for money	Admixing	Yield	Value for money	Value for money	Admixing	Yield	Yield
						Stability	Stability	Purity

Drilling fluid for water well construction, flat geothermal energy and exploration drilling

With the introduction of mobile, hydraulically powered flush drilling rigs at the end of the 50s, the topic of flushing methods in water well construction increasingly gained importance. Through the controlled use of flushing agents in water-based drilling fluids, it was possible to meet the continually growing demand among owners for deeper, larger and more powerful wells.

The rapid execution of uncased flush drilling to construct wells, quality measurement points, geothermal energy plants, seismic blasthole drilling, coring in subsoil investigation etc. is now the state of the art thanks to the use of modern flushing products. Benefits compared with dry drilling methods include rapid drilling progress thanks to continual removal of drilling debris as well as the elimination of casings.

Drilling fluid refers to all fluids and gases that are circulated in the borehole in a controlled manner during the drilling process.

The role of a drilling fluid is primarily:

- Removing of cuttings from the borehole base up to ground level
- Keeping open and stabilizing the uncased borehole wall
- Compensation of increased rock and deposit pressures (water/oil/gas)
- Cooling and lubrication of drilling tools
- Conservation of the levels/deposits drilled for exploitation

Based on experience, these requirements cannot be adequately fulfilled exclusively using pure water as a flushing medium. For that reason, the use of pure water is limited to a few specific cases, for example drilling in stable hard rock with low permeability.

Removing of cuttings

Removing of cuttings from the borehole base up to ground level is primarily influenced by 3 factors:

- Flow speed of the fluid rising in the borehole
- Density difference between flushing fluid and drilled stone
- Viscosity of the drilling fluid

Particularly for drilling methods with a direct fluid flow direction (pressure flush drilling), the drilling equipment (chisel and rod diameter, flushing pump) must be designed so that flow speeds of the rising fluid between 0.5-1.0 m/s are achieved in the annular gap of the excavated borehole.

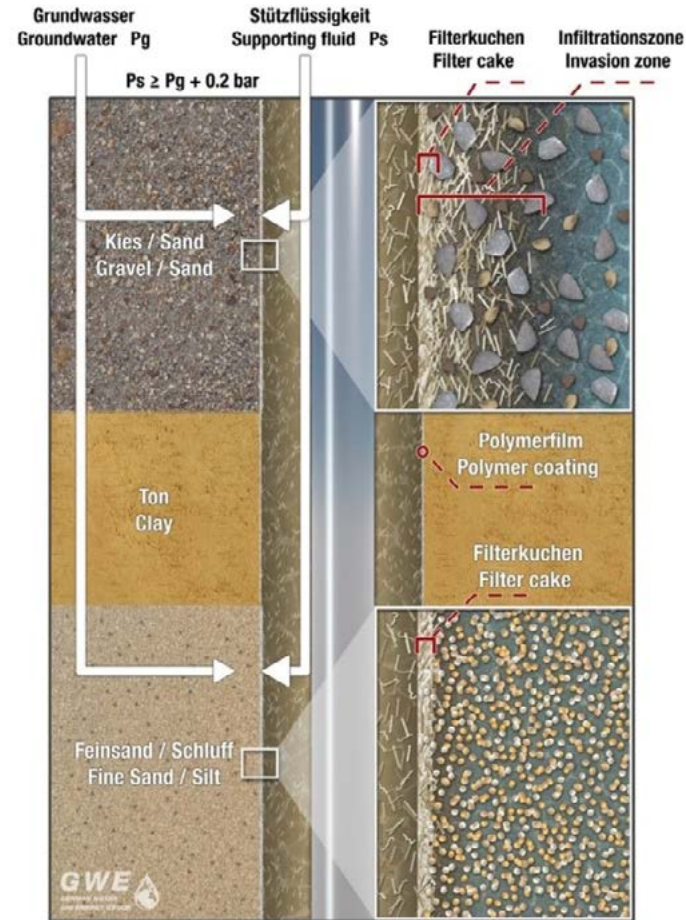

The smaller the density difference between the drilled solids (ca. 2.6 kg/l) and the drilling fluid, the lower their speed of sedimentation. Increasing the density of a drilling fluid with the goal of improving its load-bearing capacity is not useful, however, as heavy fluids with high solid content reduce drilling progress and increase the risk of permanent clogging in the borehole areas intended for exploitation.

Instead, the goal is to use flushing systems with a low solid content that are gentle on the carrier rock, whose load-bearing capacity is regulated by the addition of flushing agents that increase the viscosity.

Stabilization of the borehole

In order to prop up the uncased borehole, a fluid head pressure is generally required which exceeds the pressure exerted by the groundwater and the earth. Based on experience, an excess hydrostatic pressure of 2 m water head (0.2 bar) is sufficient. In addition, an area near the borehole must be secured as an impermeable zone in order for the fluid head pressure to effectively counteract the earth and groundwater pressure and prevent the loss of drilling fluid. Ideally, this impermeable zone is a filter cake that is as thin and dense as possible.

Apart from propping up the loose sediment which tends to fall down, another crucial function of drilling fluid is to prevent borehole instabilities caused by the hydration of drilled clay mineral rock components. Clay-inhibiting fluid polymers, potentially in combination with sodium chloride or potassium chloride, act to prevent or slow down the time progression of the instabilities described above, so that boreholes with consistent calibers can be constructed even under difficult geological conditions.

The required excess hydrostatic pressure of the fluid head in comparison to the groundwater pressure in the aquifer, causes fluid to penetrate the area near the borehole and form an impermeable zone as described above. To obtain free access to the water-bearing levels intended for exploitation, this sealing must be flushed out when constructing the well. For this reason, the controlled use of a polymer fluid with low solid content should be planned as long as the borehole situation permits this. The low solid content combined with a filtrate-reducing fluid polymer minimizes the infiltration at the borehole wall, resulting in thin, easily removable filter cakes.

Apart from this, it is also recommended to directly monitor the filtration behavior using API press water tests (guideline values: API press water < 10 ml, filter cake thickness < 1 mm). To obtain a drilling fluid that is gentle on the carrier rock, an excessive load of fine drilled solids must be prevented during the drilling process. Based on experience, fluids with a high solid content penetrate deeply into the aquifer due to their higher net weight and form thick filter cakes that are difficult to remove. As long as the borehole situation permits, the drilling fluid in the borehole areas requiring filtration (DVGW recommendation W 116) should not exceed a fluid density of 1.08 kg/l.

The load-bearing capacity and viscosity of the drilling fluid can be reviewed relatively easily by measuring the Marsh funnel time for flowing out:

Recommended guideline values:

Time for flowing out (AZ): 38–45 s

Remaining time for flowing out (RAZ): 28–35 s

With these times for flowing out, sufficient load-bearing capacities are generally achieved in order to transport drilled solids up to the ground level and their sedimentation in the inert zones of the fluid tank is enabled.

In principle, suitable documentation must be maintained of the drilling fluid parameters as well as information about the volume and type of flushing agents/water volumes, not least in order to demonstrate the quality of the own work performed.

Drilling fluid recipes

The choice of drilling fluids is generally determined by the following circumstances:

- Stability of the rock
- Permeability of the rock
- Pressure conditions in the rock
- Drilling method

The use of water without additives as a flushing medium is limited to a few specific cases, for example drilling in stable hard rock with low permeability. In loosely bedded sands/gravels, sufficient borehole stabilization cannot be achieved with this method. In addition, water or pure bentonite fluids can only be used to a limited extent in clay-based, cohesive sediments. Due to a lack of inhibiting properties and encapsulating effect, rapid concentration of solids generally occurs and the existing clays cause caliber restriction due to the swelling that results or cratering due to collapse. Furthermore, the pores in the aquifer are blocked more strongly and permanently by the drill spoil in the fluid, such as sand, clay and silt, than by correctly dosed drilling fluid additives.

Tixoton

Product description

Tixoton is an active bentonite to increase the load-bearing capacity and viscosity of drilling fluid and stabilizing slurries.



Product characteristics

- Composition: Sodium bentonite
- Exterior: Beige powder
- Pouring weight: 750 kg/m³

Areas of application and product characteristics

Tixoton increases the load-bearing capacity and viscosity of drilling fluid and stabilizing slurries. When dispersed in water, it creates stable, thixotropic slurries that are capable of securely stabilizing even coarse sediments. Thanks to their thixotropic characteristics, Tixoton drilling fluids are capable of gelling when at rest and keep drilled solids in suspension. Tixoton

fluids in combination with polymers form thin, well-sealing filter cakes that are gentle on the carrier rock. Furthermore, Tixoton forms the basis for weighted drilling fluids. During the admixture process, Tixoton should pre-soak for at least 2 h before it is treated with polymers or introduced into the drilling fluid circuit.

Dosing

As sole additive	1 m ³ water + 40–60 kg Tixoton
In combination with polymers	1 m ³ water + 20 kg bentonite + 2 kg Viscopol® R
Or	+ 4 kg Viscopol® T

Key drilling fluid figures in new batch

Standard fluid	Marsh time for flowing out s	Density kg/l	Water release time s	API press water ml
1 m ³ water + 20 kg Tixoton + 2 kg Viscopol® R	65	1.015	> 2,000	18

Packaging

Tixoton is available for delivery in 25 kg paper sacks with PE interior lining.

GWE PolyMix®

Product description

Ready-mix product made of active bentonite and polymers for easy production of drilling fluid.



Product characteristics

- Composition: Active bentonite and polymer
- Exterior: Beige powder
- Pouring weight: 750 kg/m³

Areas of application and product characteristics

With GWE PolyMix®, a fully functional bentonite-polymer basic drilling fluid can be produced without pre-soaking time. The optimally coordinated components generate a usable universal drilling fluid immediately after the addition of PolyMix®. All

requirements for a drilling fluid are met, such as good load-bearing capacity, press water reduction and clay inhibition. PolyMix® can be combined with all common flushing additives.

Dosing

Coarse gravel	1 m ³ water + 25 kg PolyMix®
Coarse gravel/coarse sand	1 m ³ water + 20 kg PolyMix®
Silt/marl/clay	1 m ³ water + 15 kg PolyMix®

Key drilling fluid figures in new batch

Standard fluid	Marsh time for flowing out s	Density kg/l	Water release time s	API press water ml
1 m ³ water + 20 kg PolyMix®	50	1.01	> 400	16

Packaging

PolyMix® is available for delivery in 25 kg paper sacks with PE interior lining.

Viscopol® T

Product description

High viscosity CMC polymer to regulate the flow and filtration characteristics of drilling fluids.



Product characteristics

- Composition: Sodium carboxymethylcellulose, technical
- Exterior: Whitish fine granule
- Pouring weight: approx. 550 kg/m³
- Ionogenicity: anionic
- pH value: neutral

Areas of application and product characteristics

Viscopol® increases the load-bearing capacity and viscosity of drilling fluids without the formation of thixotropic gelling structures. In combination with fine drilled solids or added bentonite, this results in very thin and impermeable filter cakes that can be easily flushed during well construction. Water-sensitive clay-based drilling debris is inhibited and sedimented effectively in the inert zones of the fluid tank. This strongly reduces the load

on the circulating drilling fluid. Due to the inhibiting characteristics of a Viscopol® T drilling fluid, water absorption of swellable drilled rock is suppressed, resulting in dimensionally stable boreholes. Viscopol® T also acts as a protective colloid and prevents the flocculation of dispersed bentonite when drilling in areas with high mineral levels.

Dosing

In clay-based sediments	1 m ³ water + 6 kg Viscopol® T
In alternating layers of gravel/sand/clay	1 m ³ water + 20–30 kg bentonite + 3–4 kg Viscopol® T

Key drilling fluid figures in new batch

Standard fluid	Marsh time for flowing out s	Density kg/l	Water release time s	API press water ml
1 m ³ water + 20 kg bentonite + 4 kg Viscopol® T	66	1.015	> 2,000	12.5

Packaging

Viscopol® T is available for delivery in 25 kg paper sacks with PE interior lining.

Viscopol® TLV

Product description

Low viscosity CMC polymer to regulate the flow and filtration characteristics of drilling fluids and stabilizing slurries with high solid content.



Product characteristics

- Composition: Sodium carboxymethylcellulose, technical
- Exterior: Whitish fine granule
- Pouring weight: approx. 550 kg/m³
- Ionogenicity: anionic
- pH value: neutral

Areas of application and product characteristics

Viscopol® TLV improves the flow capacity of viscous drilling fluids with a high solid content. In combination with fine drilled solids or added bentonite, this results in very thin and impermeable filter cakes that can be easily flushed. Water-sensitive clay-based drilling debris is inhibited and sedimented effectively in the inert zones of the fluid tank. This strongly reduces

the load on the circulating drilling fluid. Due to the inhibiting characteristics of a Viscopol® TLV drilling fluid, swelling and collapse of swellable drilled sediments is suppressed, resulting in dimensionally stable boreholes. Viscopol® TLV also acts as a protective colloid and prevents the flocculation of dispersed bentonite when drilling in areas with high mineral levels.

Dosing

For flow improvement	1 m ³ water + 5–10 kg Viscopol® TLV
Standard fluids	1 m ³ water + 30 kg bentonite + 10 kg Viscopol® TLV

Key drilling fluid figures

Standard fluid	Marsh time for flowing out s	Density kg/l	Water release time s	API press water ml
1 m ³ water + 30 kg bentonite + 10 kg Viscopol® TLV	50	1.02	> 2,000	8

Packaging

Viscopol® TLV is available for delivery in 25 kg paper sacks with PE interior lining.

Viscopol® R

Product description

High viscosity polyanionic PAC polymer to regulate the flow and filtration characteristics of drilling fluids with low solid content.

Product characteristics

- Composition: Sodium carboxymethylcellulose
- Exterior: Whitish fine granule
- Pouring weight: 600–900 kg/m³
- Ionogenity: anionic
- Active substance percentage approx. 99%

Areas of application and product characteristics

Viscopol® R increases the load-bearing capacity and viscosity of drilling fluids without the formation of thixotropic gelling structures. In combination with fine drilled solids or added bentonite, this results in very thin and impermeable filter cakes that can be easily flushed during well construction. Water-sensitive clay-based drilling debris is inhibited and sedimented effectively in the inert zones of the fluid tank. This strongly reduces

the load on the circulating drilling fluid. Due to the inhibiting characteristics of a Viscopol® R drilling fluid, water absorption of swellable drilled sediment is suppressed, resulting in dimensionally stable boreholes. Viscopol® R also acts as a protective colloid and prevents the flocculation of dispersed bentonite when drilling in areas with high mineral levels.



Dosing

In clay	1 m ³ water + 2–4 kg Viscopol® R
In alternating layers of gravel/sand/clay	1 m ³ water + 20 kg bentonite + 1–3 kg Viscopol® R

Key drilling fluid figures in new batch

Standard fluid	Marsh time for flowing out s	Density kg/l	Water release time s	API press water ml
1 m ³ water + 20 kg bentonite + 2 kg Viscopol® R	65	1.015	> 2000	18

Packaging

Viscopol® R is available for delivery in 8 kg paper sacks with interior lining.

GWE PolyPile® HD

Product description

High viscosity fully synthetic PAA polymer for the production of drilling fluids and stabilizing slurries.

Product characteristics

- Composition: Copolymer made of acrylamide sodium acylate
- Exterior: Whitish beige granule
- Pouring weight: Approx. 700 kg/m³
- Ionogenity: anionic

Areas of application and product characteristics

PolyPile® HD has a high yield and is preferred for use in drilling fluids and stabilizing slurries with a low solid content due to its high inherent viscosity. High viscosity PolyPile® HD drilling fluids can also be used to stabilize permeable loose sediments. The polymer has good clay-inhibiting characteristics and promotes caliber consistency of boreholes in swellable lithology.

Consequently, clay-based drilling debris features high structural stability and be effectively separated using sedimentation due to the absence of a yield point. This fully synthetic polymer features high resistance against microbiological degradation processes and can be used multiple times over long periods.



Dosing

In freshwater	1 m ³ water + 0.5–1.0 kg PolyPile® HD
In sea water/saltwater	1 m ³ water + 1–2 kg PolyPile® HD

Key drilling fluid figures

Standard fluid	Marsh time for flowing out s	Density kg/l	Water release time s	API press water ml
1 m ³ water + 1 kg PolyPile® HD	50–60	1.0	> 400	-

Packaging

PolyPile® HD is available for delivery in 25 kg paper sacks with PE interior lining.

GWE PolyPile® HD-L

Product description

High viscosity fully synthetic PAA polymer in liquid form for the production of drilling fluids and stabilizing slurries.



Product characteristics

- Composition: Copolymer made of acrylamide sodium acrylate
- Exterior: Whitish emulsion
- Density: approx. 1,030 kg/m³
- Ionogenity: anionic

Areas of application and product characteristics

PolyPile® HD-L is preferred for use in drilling fluids and stabilizing slurries with a low solid content due to its high inherent viscosity. PolyPile® HD-L comes in fluid form already and can thus be added to the water supply easily without additional equipment. High viscosity PolyPile® HD-L drilling fluids can

also be used to stabilize permeable loose sediments. Another advantage lies in the high resistance of fully synthetic polymers to biological degradation processes, which prevents the use of biocides even during longer downtimes.

Dosing

In freshwater	1 m ³ water + 1–3 kg PolyPile® HD-L
In sea water/saltwater	1 m ³ water + 2–5 kg PolyPile® HD-L

Key drilling fluid figures

Standard fluid	Marsh time for flowing out s	Density kg/l	Water release time s	API press water ml
1 m ³ water + 2.5 kg PolyPile® HD-L	50–60	1.0	> 400	-

Packaging

PolyPile® HD-L is available for delivery in 25 kg plastic canisters.

Hostapur OS

Product description

Foaming and wetting agent for drilling with air as a flushing medium.



Product characteristics

- Composition: Sodium alkyl ether sulphate in aqueous solution
- Exterior: Yellowish liquid
- Density: approx. 1.07 kg/m³
- Active substance percentage approx. 42%

Areas of application and product characteristics

Hostapur OS forms very stable foams that improve the removal of drilling debris in air-based flushing. Water flowing into the borehole is removed by foaming. In addition, dust formation above ground is prevented. The product is

biodegradable. Swellable rock can be stabilized by the addition of high viscosity clay-inhibiting polymers, e.g. Viscopol® R. Furthermore, polymers improve foam stability and its load-bearing capacity.

Dosing

High air flow in annular gap	1 m ³ water + 2–3 l Hostapur OS
Low air flow	1 m ³ water + 1 kg Viscopol® R + 10 l Hostapur OS

Packaging

Hostapur OS® is available for delivery in 25 kg paper canisters and 1,000 kg IBC.



8. Well covers

Specialist knowledge	192
Well heads	194
Formed parts and pipe accessories	200
Well shafts made of reinforced concrete	206
Well shafts made of stainless steel	209
Well houses	210
Well hoods	212
Accessories for well shafts and well houses	216



Access current information about the product area online

Well covers – An important detail in water well construction

Together with the well head, well closure structures serve to close off the well or well extension. The well closure structure protects the well and its operating equipment against external influences and damages, prevents contamination of the groundwater in the well, and accommodates pipelines that connect to external facilities, such as measurement and control equipment.

Through the well head, the load is transferred from the weight of the riser pipes and pumps into the concrete base plate of the well closure structure so that the casings are not subjected to additional stress.

The technical requirements are specified by DVGW Rulebook – Worksheet W122.

For in-ground installation, apart from classic cement shafts in round and rectangular designs, well shafts made entirely of stainless steel are also available. Shafts installed in the ground are attractive due to their security against intrusion and frost, and blend in seamlessly with the environment. For use in hard to access terrain, the significantly reduced-weight model made of stainless steel is preferable to the heavy concrete model.

In combination with a concrete base plate for uplift prevention, the stainless steel model offers a permanently watertight and hygienically clean well closure even in flood regions.

Apart from classical well shafts, above-ground well closure structures are also used in the form of well houses and well hoods. The benefits of above-ground models lie in their easier maintenance and considerably better accessibility along with the associated risk factors. Accident and safety regulations are easier to observe, since dangers posed by falling when climbing or the collection of gases in the closure can be excluded or minimized. Furthermore, above-ground components offer a useful alternative to classic well shafts even with higher groundwater levels. While well houses are manufactured out of solid concrete and sometimes include exterior insulation and plaster, the area of well hoods includes lightweight models made of FRP and in sandwich design.



Well heads – GWE PVC well head

Product description

The GWE well head is placed onto the well pipe and glued on. This offers a simple, economical and secure well connection. The easy-to-install capping beam of the well head also enables rapid access to the well.

Product characteristics

- Material: Capping beam made of PU/bottom part made of PU/PVC-U
- O-ring sealing between capping beam and flange ensures rainwater tightness
- Attachment possible using conventional PVC-U adhesives (e.g. Tangit)
- Enhanced leak tightness up to 1 bar possible by using a flat seal

Benefits

- Cable glands with metric connection thread
- Stainless steel screws with optimized diameter
- Threaded coupler made of stainless steel guarantees a secure, dimensionally stable screw connection even after multiple installation and dismantling of pump riser pipe
- Greater ease of installation with integrated hexagonal mount on the underside of the flange
- PVC pipe with adhesive socket for secure well closure
- Dimensional specifications on the well head cap

Technical data

DN*	Thread	External Ø mm	Height approx. mm	Screws	Load-bearing capacity kN
80	1"-1 ¼"	165	190	4 x M8	7.5
100	1 ¼"-2"	185	200	4 x M8	7.5
115	1 ¼"-2"	185	210	4 x M8	7.5
125	1 ¼"-2"	225	210	6 x M 12	10.0
150	1 ¼"-2"	250	220	6 x M 12	10.0
175	1 ¼"-2"	280	280	6 x M 12	10.0
200	1 ¼"-2"	320	300	6 x M 16	15.0
250	2"-4"	375	340	6 x M 16	15.0
300	2"-4"	425	400	6 x M 16	15.0

*Larger dimensions available by request



Well heads – GWE steel well head

Product description

GWE well heads are manufactured according to DIN 4926 or based on the DIN requirements according to the GWE works standard as well as the DVGW directives. Apart from several standard designs that are in stock and ready for fast delivery, we are also able to design and manufacture individual special solutions.

Our in-house design department has a high degree of experience and creates designs based on your individual requirements.

Product characteristics and models

- Material: Stainless steel 1.4301/1.4307 (V2A) and 1.4571/1.4404 (V4A) stained and passivated in dip tank. Special alloys, such as duplex (1.4462) and superduplex (1.4410), on request. Steel, galvanized and raw-black.
- Manufacture according to GWE works standard or DIN 4926
- Standard model with permanently welded media passage, 1x aeration and ventilation, 2x gauge opening and 2x cable gland
- Water pressure-tight models up to 2 bar
- Well head pipe sleeve with wall flange for concrete installation, alternatively with base flange for bolting and fastening with screws on shaft floor or existing flange, or with a smooth end for welding on
- Well head cover flange in single-piece, center-split or separately installable and removable models with individual extenders and carrier flange
- Riser pipe connections with ZSM connection, flange connection or thread connection



Benefits

- Individual and customer-specific special solutions possible
- In-house design department for customer-specific development
- Fast delivery capacity of standard models
- Suitable connection to GWE riser pipe systems

Accessories

- Ventilation and aeration with insect filter or ventilation and aeration valves
- Gauge pipe feedthroughs and sounding openings
- Flange sockets, discharge sockets and pipe connections
- Gusset plates and reinforcement ribs
- Cable glands
- Connection for equipotential bonding
- Lifting lugs

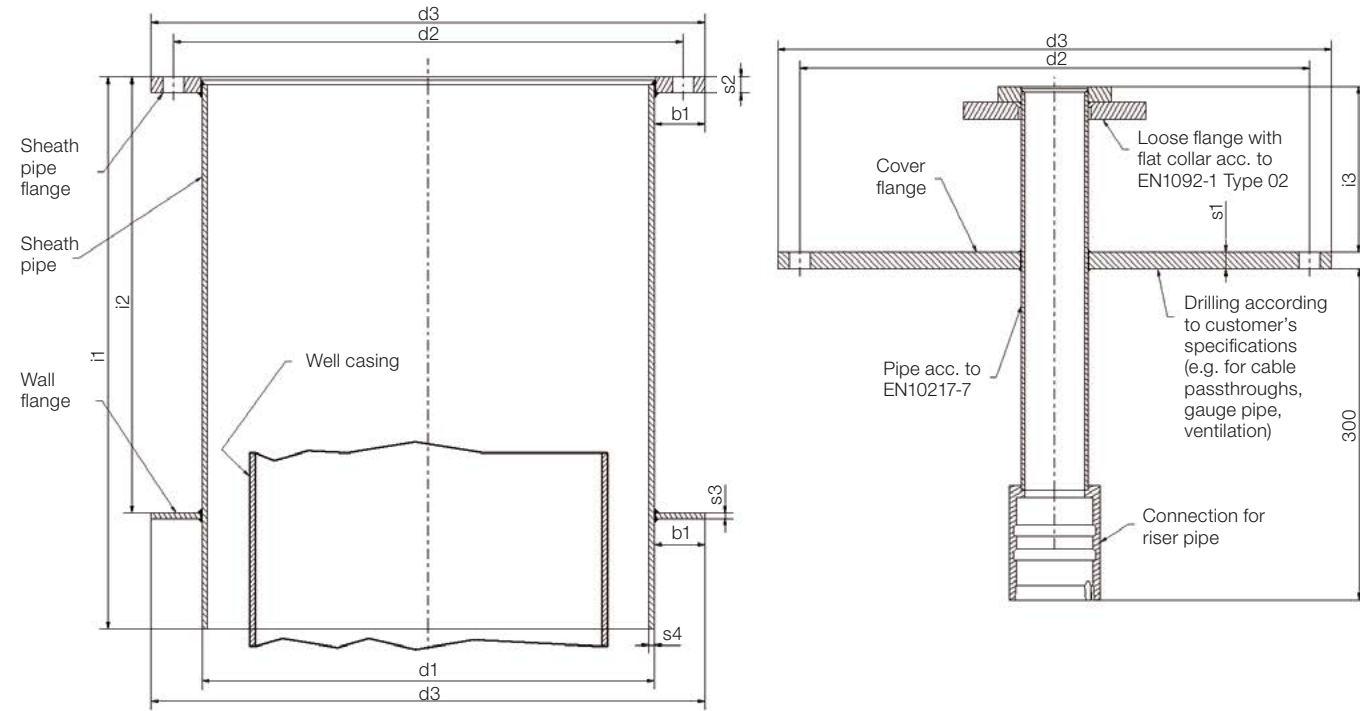

Technical data

DN	Sheath pipe/protective pipe			Cover flange/lid flange						Wall flange and riser pipe		
	d1	s4	l1	d2	d3	b1 x s2	s1*) min.	Number of holes x hole diameter	Hexagon screws	b1 x s3	l2	l3
200	219.1	4	According to customer's specifications	271	311	45 x 15	15	8 x 15	M12 x 50	45 x 5	According to customer's specifications	150
250	273	4		325	365	45 x 15	15	8 x 15	M12 x 50	45 x 5		150
300	323.9	5		376	416	45 x 15	15	8 x 15	M12 x 50	45 x 5		150
350	360	5		412	452	45 x 15	15	8 x 15	M12 x 50	45 x 5		150
400	410	5		462	502	45 x 15	15	12 x 19	M16 x 55	45 x 5		150
450	460	5		512	552	45 x 15	15	12 x 19	M16 x 55	45 x 5		150
500	510	5		562	602	45 x 15	15	12 x 19	M16 x 55	45 x 5		150
550	560	5		612	652	45 x 15	15	12 x 19	M16 x 55	45 x 5		150
600	612	6		662	704	45 x 15	20	16 x 19	M16 x 65	45 x 6		150
650	662	6		712	754	45 x 15	20	16 x 19	M16 x 65	45 x 6		150
700	712	6		762	804	45 x 15	20	16 x 19	M16 x 65	45 x 6		200
750	762	6		812	854	45 x 15	20	16 x 19	M16 x 65	45 x 6		200
800	816	8		872	918	50 x 20	20	20 x 19	M16 x 70	50 x 8		200
850	866	8		922	968	50 x 20	20	20 x 19	M16 x 70	50 x 8		200
900	916	8		972	1,018	50 x 20	25	20 x 19	M16 x 70	50 x 8		200
1,000	1,016	8		1,072	1,118	50 x 20	25	28 x 19	M16 x 70	50 x 8		200
1,200	1,220	10	1,272	1,324	50 x 20	30	28 x 19	M16 x 80	50 x 10	200		

*) The thickness specifications for cover plate s1 are minimum values and are intended for informational purposes. They were determined for a 150 m long riser pipe and a powerful submersible pump with a correspondingly high weight. In the process, the largest possible riser pipe diameter (determined by the external diameter of the flange) was used as a basis, though the max. DN was 200.

Well heads - GWE steel well head with HAGULIT® coating

Product description

GWE well heads are manufactured according to DIN 4926 or based on the DIN requirements according to the GWE works standard as well as the DVGW directives. Well heads with HAGULIT® coating are characterized by their chemical resistance and high resistance against water with high chloride concentrations. The well heads are designed and individually manufactured by our in-house design department according to the customer's requirements.



Product characteristics and models

- Material: Steel with HAGULIT® coating
- Manufacture according to GWE works standard or on request according to DIN 4926
- Well head sheath pipes with wall flange for concrete installation. Alternatively, the sheath pipes can also be designed with base flange for bolting on the shaft floor or for fastening with screws using an existing flange
- Well head cover flange in single-piece, center-split or separately installable and removable models with individual extenders and carrier flange
- Riser pipe connections with HAGULIT® ZSM connection (HAGUDOSTA®), ZSM connection (HYBRID design) or flange connection

Benefits

- Excellent and proven long-term resistance against water with high chloride concentrations
- Extensive drinking water certificates for coating KTW (D), ACS (F), WRAS (GB), KIWA (NL, DM 174 (I))
- Coating features outstanding impact strength, abrasion resistance and elasticity
- Temperature resistance of coating from -30 °C to +80 °C
- High degree of flexibility, customization and special solutions possible
- In-house design department for customer-specific development
- Suitable connection to GWE riser pipe systems

Accessories

- Ventilation and aeration with insect filter or ventilation and aeration valves
- Gauge pipe feedthroughs and sounding openings
- Flange sockets, discharge sockets and pipe connections
- Gusset plates and reinforcement ribs
- Cable glands
- Lifting lugs

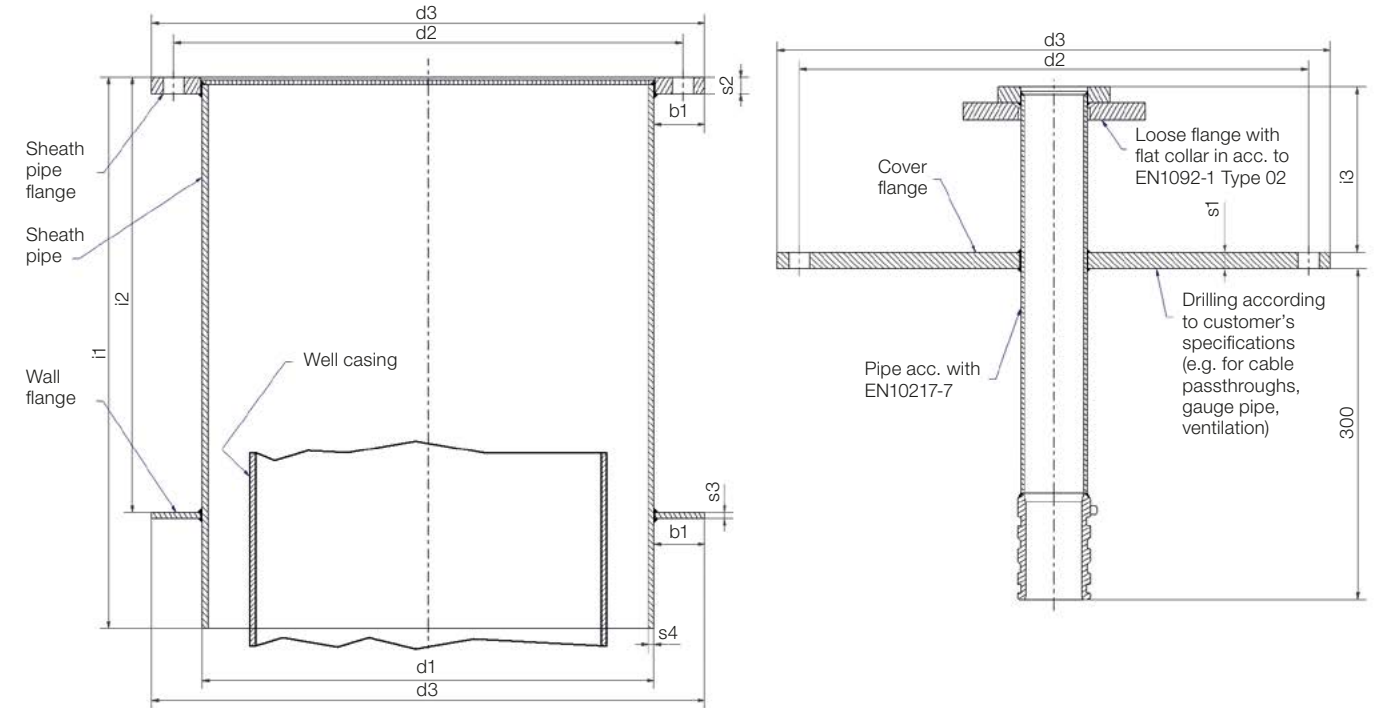

Technical data

DN	Sheath pipe/protective pipe			Cover flange/lid flange						Wall flange and riser pipe		
	d1	s4	l1	d2	d3	b1 x s2	s1*) min.	Number of holes x hole diameter	Hexagon screws	b1 x s3	l2	l3
200	219.1	4	According to customer's specifications	271	311	45 x 15	15	8 x 15	M12 x 50	45 x 5	According to customer's specifications	150
250	273	4		325	365	45 x 15	15	8 x 15	M12 x 50	45 x 5		150
300	323.9	5		376	416	45 x 15	15	8 x 15	M12 x 50	45 x 5		150
350	360	5		412	452	45 x 15	15	8 x 15	M12 x 50	45 x 5		150
400	410	5		462	502	45 x 15	15	12 x 19	M16 x 55	45 x 5		150
450	460	5		512	552	45 x 15	15	12 x 19	M16 x 55	45 x 5		150
500	510	5		562	602	45 x 15	15	12 x 19	M16 x 55	45 x 5		150
550	560	5		612	652	45 x 15	15	12 x 19	M16 x 55	45 x 5		150
600	612	6		662	704	45 x 15	20	16 x 19	M16 x 65	45 x 6		150
650	662	6		712	754	45 x 15	20	16 x 19	M16 x 65	45 x 6		150
700	712	6		762	804	45 x 15	20	16 x 19	M16 x 65	45 x 6		200
750	762	6		812	854	45 x 15	20	16 x 19	M16 x 65	45 x 6		200
800	816	8		872	918	50 x 20	20	20 x 19	M16 x 70	50 x 8		200
850	866	8		922	968	50 x 20	20	20 x 19	M16 x 70	50 x 8		200
900	916	8		972	1,018	50 x 20	25	20 x 19	M16 x 70	50 x 8		200
1,000	1,016	8	1,072	1,118	50 x 20	25	28 x 19	M16 x 70	50 x 8	200		

*) The thickness specifications for cover plate s1 are minimum values and are intended for informational purposes. They were determined for a 150 m long riser pipe and a powerful submersible pump with a correspondingly high weight. In the process, the largest possible riser pipe diameter (determined by the external diameter of the flange) was used as a basis, though the max. DN was 200.

GWE formed parts and pipe accessories

Formed parts

Design:
Standard design with V flanges according to EN 1092-1:2007 (D) Type 11 (previously DIN 2633/2632)

Welded connections:
GWE meets the welding quality requirements for manufacturers and is certified in accordance with the international standard DIN EN ISO 3834-2. Additional requirements for the welding seam quality must be arranged for the specific product.

Materials:
Stainless steel, steel

Surface:
Stainless steel, stained and passivated in dip tank
Steel with HAGULIT® coating or galvanized

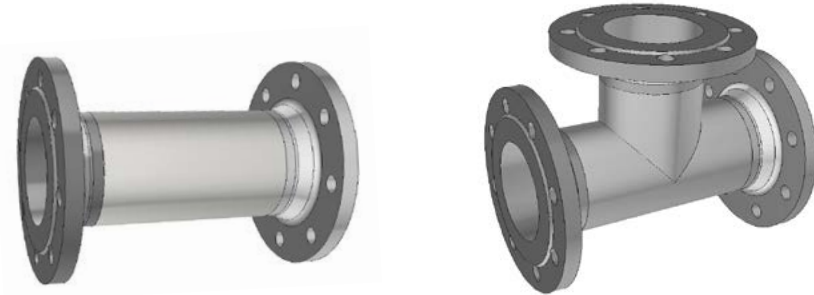

Standard pipe dimensions GWE formed parts

DN	Pressure rating	Dimensions stainless steel	Dimensions steel
40	PN 16	Ø 48.3 x 2.0 mm	Ø 48.3 x 2.3 mm
50	PN 16	Ø 60.3 x 2.0 mm	Ø 60.3 x 2.3 mm
65	PN 16	Ø 76.1 x 2.0 mm	Ø 76.1 x 2.9 mm
80	PN 16	Ø 88.9 x 2.6 mm	Ø 88.9 x 2.9 mm
100	PN 16	Ø 114.3 x 3.0 mm	Ø 114.3 x 3.2 mm
125	PN 16	Ø 139.7 x 3.0 mm	Ø 139.7 x 3.6 mm
150	PN 16	Ø 168.3 x 3.0 mm	Ø 168.3 x 4.0 mm
200	PN 10	Ø 219.1 x 3.0 mm	Ø 219.1 x 4.5 mm
200	PN 16	Ø 219.1 x 4.0 mm	Ø 219.1 x 4.5 mm
250	PN 10	Ø 273.0 x 4.0 mm	Ø 273.0 x 5.0 mm
250	PN 16	Ø 273.0 x 5.0 mm	Ø 273.0 x 5.0 mm
300	PN 10	Ø 323.9 x 4.0 mm	Ø 323.9 x 5.0 mm
300	PN 16	Ø 323.9 x 5.0 mm	Ø 323.9 x 5.0 mm

Additional wall thicknesses, pressure ratings and designs with smooth flange or connecting/detachable flange on request.

We offer additional outlets/connections as welded sleeves, nipples or flange sockets for measuring and aeration equipment etc.

Q pieces

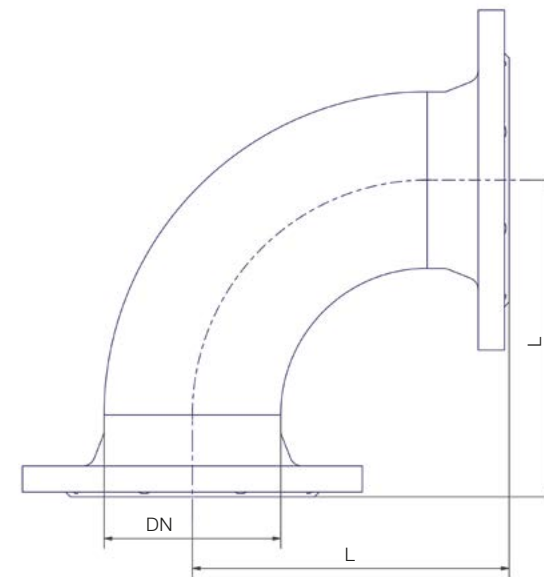

Standard version with pipe bend 3d

Leg length (L)	
DN 40 PN 16:	100 mm
DN 50 PN 16:	122 mm
DN 65 PN 16:	141 mm
DN 80 PN 16:	166 mm
DN 100 PN 16:	206 mm
DN 125 PN 16:	247 mm
DN 150 PN 16:	285 mm
DN 200 PN 10:	368 mm
DN 200 PN 16:	368 mm
DN 250 PN 10:	450 mm
DN 250 PN 16:	452 mm
DN 300 PN 10:	526 mm
DN 300 PN 16:	536 mm

Additional versions with pipe bends in 2d/5d/10d as well as extended pipe legs on request.

F pieces

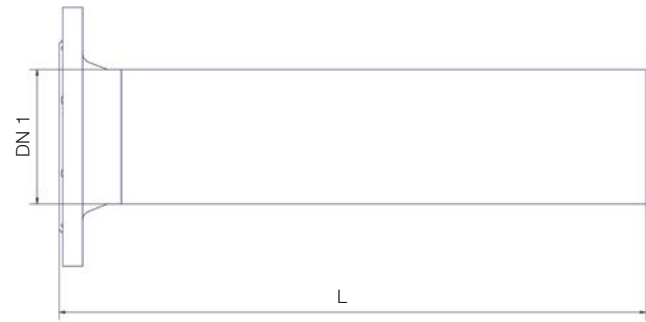

Standard structural length (L)

DN 40 PN 16:	250/500/750/1,000 mm
DN 50 PN 16:	250/500/750/1,000 mm
DN 65 PN 16:	250/500/750/1,000 mm
DN 80 PN 16:	250/500/750/1,000 mm
DN 100 PN 16:	250/500/750/1,000 mm
DN 125 PN 16:	250/500/750/1,000 mm
DN 150 PN 16:	250/500/750/1,000 mm
DN 200 PN 10:	250/500/750/1,000 mm
DN 200 PN 16:	250/500/750/1,000 mm
DN 250 PN 10:	250/500/750/1,000 mm
DN 250 PN 16:	250/500/750/1,000 mm
DN 300 PN 10:	250/500/750/1,000 mm
DN 300 PN 16:	250/500/750/1,000 mm

FF pieces

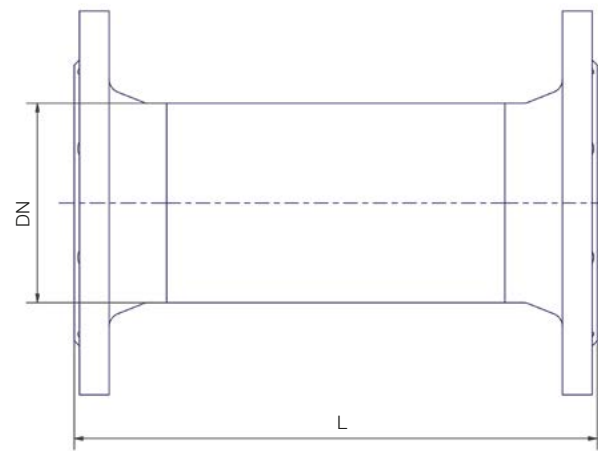

Standard structural length (L)

DN 40 PN 16:	250/500/750/1,000 mm
DN 50 PN 16:	250/500/750/1,000 mm
DN 65 PN 16:	250/500/750/1,000 mm
DN 80 PN 16:	250/500/750/1,000 mm
DN 100 PN 16:	250/500/750/1,000 mm
DN 125 PN 16:	250/500/750/1,000 mm
DN 150 PN 16:	250/500/750/1,000 mm
DN 200 PN 10:	250/500/750/1,000 mm
DN 200 PN 16:	250/500/750/1,000 mm
DN 250 PN 10:	250/500/750/1,000 mm
DN 250 PN 16:	250/500/750/1,000 mm
DN 300 PN 10:	250/500/750/1,000 mm
DN 300 PN 16:	250/500/750/1,000 mm

FFR pieces

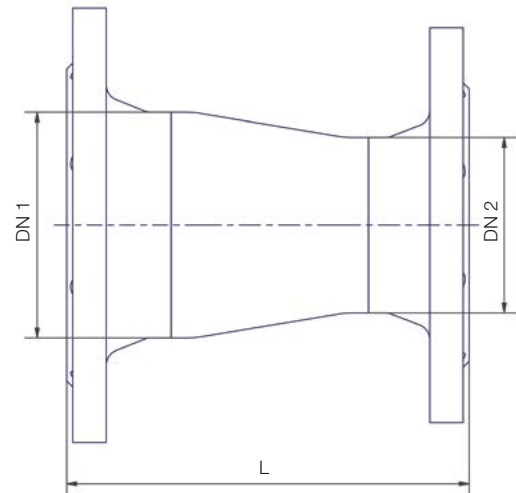

Standard design with concentric reduction

DN 1	DN 2	L
40	50/65/80	165/179/184 mm
50	65/80/100	182/187/199 mm
65	80/100/125	187/199/229 mm
80	100/125/150	204/234/247 mm
100	125/150/200	236/249/268 mm
125	150/200/250	252/271/305 mm
150	200/250/300	271/305/338 mm
200	250/300/350	312/345/476 mm
250	300/350/400	353/484/512 mm

T pieces

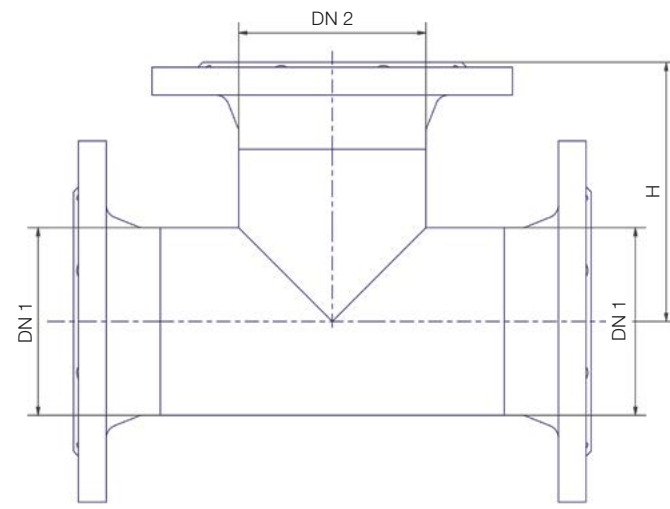

DN 1	DN 2	L	H
50	50	220 mm	110 mm
	40	220 mm	103 mm
	32	220 mm	98 mm
65	65	244 mm	122 mm
	50	244 mm	116 mm
	40	244 mm	110 mm
80	80	274 mm	137 mm
	65	274 mm	129 mm
	50	274 mm	122 mm
100	100	316 mm	158 mm
	80	316 mm	149 mm
	65	316 mm	141 mm
125	125	360 mm	180 mm
	100	360 mm	170 mm
	80	360 mm	161 mm
150	150	398 mm	199 mm
	125	398 mm	192 mm
	100	398 mm	183 mm
200	200	482 mm	241 mm
	150	482 mm	224 mm
	125	482 mm	218 mm
250	250	574 mm	287 mm
	200	574 mm	263 mm
	150	574 mm	250 mm
300	300	666 mm	333 mm
	250	666 mm	311 mm
	200	666 mm	293 mm
350	350	724 mm	362 mm
	300	724 mm	349 mm
	250	724 mm	328 mm
400	400	782 mm	391 mm
	350	782 mm	388 mm
	300	782 mm	374 mm

Additional versions with eccentric reductions as well as extended pipe legs on request.

Fitting and extension pieces - stationary

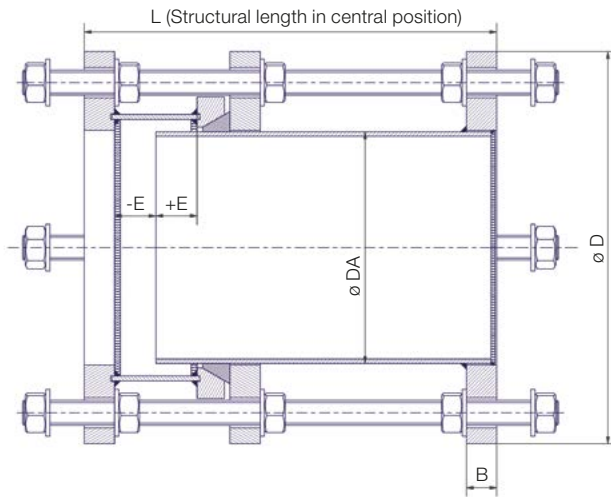

Fitting and extension pieces – stationary – to create options for installation and extension and to offset length and mounting differences. With a continuous threaded rod in every other flange hole. Sealing with KTW (drinking water plastic) approval and chloride-resistant.

Standard structural lengths and adjustability

DN 50	300 mm	+/- 25 mm
DN 65	300 mm	+/- 25 mm
DN 80	300 mm	+/- 25 mm
DN 100	300 mm	+/- 25 mm
DN 125	300 mm	+/- 25 mm
DN 150	300 mm	+/- 25 mm
DN 200	300 mm	+/- 25 mm
DN 250	300 mm	+/- 25 mm
DN 300	300 mm	+/- 25 mm

Pipe supports

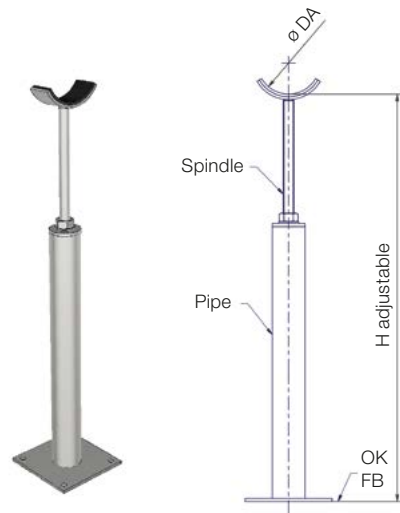

Pipe bottom support with 1/3 support shell

For floor-side pipe storage. Design as loose support with rubber cladding of 1/3 shell.

Floor mounting using dowels on load-bearing concrete or masonry.

Pipe diameter (DA):	Ø 48.3–323.9 mm
Standard heights (H):	300/400/500/ 600/700/800/ 900/1,000 mm
Height adjustability:	up to +/- 100 mm

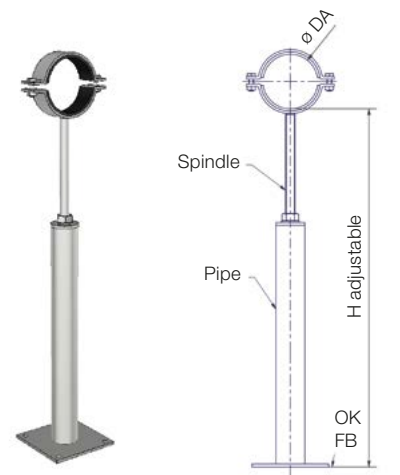

Pipe bottom support with screw shell

For floor-side pipe storage and as pipe suspension. Design as fixed storage in a rubber-cladded pipe clamp.

Floor mounting/ceiling mounting using dowels on load-bearing concrete or masonry.

Pipe diameter (DA):	Ø 48.3–323.9 mm
Standard heights (H):	300/400/500/ 600/700/800/ 900/1,000 mm
Height adjustability:	up to +/- 100 mm

Shear protection clamps

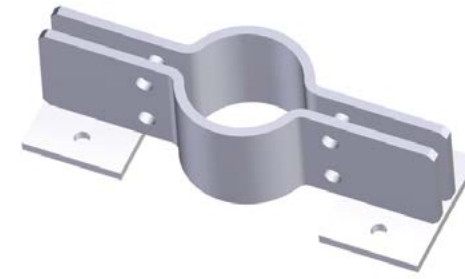

For friction-locked absorption of axial tension and shearing forces on pipes. Mounting on the shaft wall or shaft floor using dowels.

Designs for straight or round/arc'd shaft walls are possible.

DN	for pipe Ø	Length	Width
40	48.3 mm		110 mm
50	60.3 mm	283 mm	110 mm
65	76.1 mm		110 mm
80	88.9 mm	320 mm	110 mm
100	114.3 mm	365 mm	120 mm
125	139.7 mm	385 mm	120 mm
150	168.3 mm	415 mm	120 mm
200	219.1 mm	520 mm	150 mm
250	273.0 mm	575 mm	150 mm
300	323.9 mm	642 mm	150 mm

Other custom dimensions available on request.

Well shafts made of reinforced concrete, DN 1,500, 2,000, 2,500 x 2,000 mm, single-piece, safe to walk on

Product description

Water pressure-tight GWE well shaft in accordance with DVGW guidelines (W122) made from embedded precast reinforced concrete units in accordance with DIN 1045-4 in compact design as a single-piece shaft structure with factory-made concrete roof panel with circumferential drip edge. Suitable for use in areas without traffic loads.



Product characteristics and models

- Concrete: Waterproof concrete C35/45 according to DIN EN 206-1/DIN 1045-2
- Exposure class: XC4, XF3, XA1, without XD, without X
- Moisture class: WA
- Reinforcing steel: B500A/B according to DIN 488
- Load class: Foot traffic, without vehicle loads

Benefits

- Turnkey structure including pipelines from a single source
- Waterproof bentonite with a max. water penetration depth of 15 mm
- Constructional engineering by GWE according to customer requirements
- Fast and easy installation in existing excavation pit
- Single-piece shaft structure - no assembly required on site
- Pre-assembly of pipe system in factory available

Technical data

Well shaft	DN 1,500	DN 2,000	DN 2,500
Internal diameter	1,500 mm	2,000 mm	2,500 mm
Inner height, shell dimensions	2,050 mm	2,000 mm	2,000 mm
Wall thickness	150 mm	100 mm	150 mm
Roof thickness	100 mm	200 mm	200 mm
Floor thickness	200 mm	200 mm	200 mm
Weight (without uplift prevention)	6.5 t	8.0 t	12.5 t
Shaft covers	Up to 1 x DN 1,000	Up to 2 x DN 800	Up to 2 x DN 1,000

Including

- Roof openings for shaft covers
- Roof passthrough for aeration pipe
- Sloping screed
- Sump pit with grating cover
- Concrete installation of well head or floor opening



Optional

- Shaft covers
- Uplift prevention
- Coring for pipelines and cable entry
- Grounding connection
- Floor tiles
- Inside coating of walls and roof with silicate paint
- Outside bitumen coating

Design

Example design of a well shaft DN 2,000 x 2,000 with well head and pipe system.

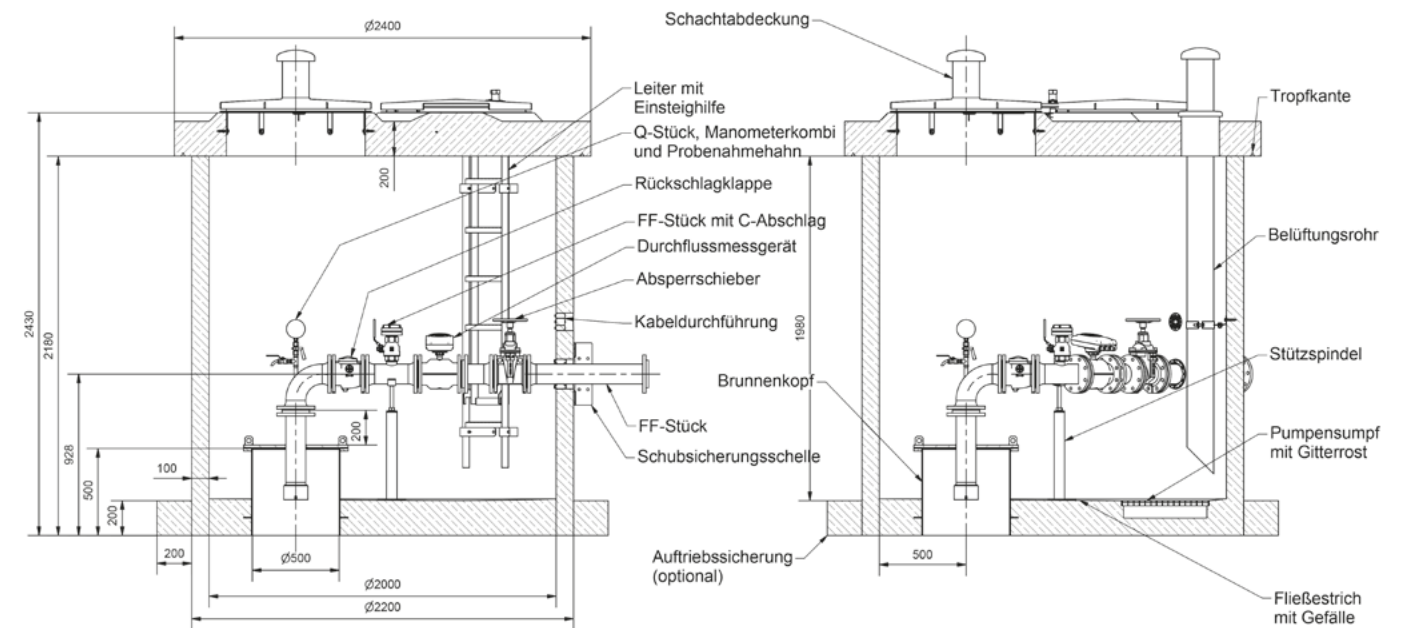

Model DN 1,500 x 2,050



Model DN 2,500 x 2,000 with uplift prevention

Other dimensions as well as vehicle-accessible and flood-safe well shafts available on request.

Well shafts made of reinforced concrete DN 1,500, 2,000, 2,500 x 2,000 mm, multi-piece

Product description

Water pressure-tight well shaft in accordance with DVGW guidelines (W122) made from precast reinforced concrete units as a 2-piece shaft structure consisting of a lower shaft section and roof panel with sleeve connection in accordance with DIN 4034-1 with mechanical seal and load balancing ring.

Product characteristics

- Concrete: Waterproof concrete C35/45 according to DIN EN 206-1/DIN 1045-2, SVB, SR3
- Exposure class: XC4, XF3, XA2, XM1
- Moisture class: WA
- Reinforcing steel: B500A/B according to DIN 488
- Load class: vehicle traffic, SLW 60/FB 101

Benefits

- Waterproof bentonite with a max. water penetration depth of 15 mm
- Constructional engineering by GWE according to customer requirements
- Fast and easy installation in existing excavation pit
- Pre-assembly of pipe system in factory available

Technical data

Well shaft	DN 1,500	DN 2,000	DN 2,500
Internal diameter	1,500 mm	2,000 mm	2,500 mm
Inner height, shell dimensions	2,000 mm	2,000 mm	2,000 mm
Wall thickness	150 mm	150 mm	150 mm
Roof thickness	200 mm	200 mm	200 mm
Floor thickness	200 mm	200 mm	200 mm
Weight (without uplift prevention)	Max. unit weight 5.8 t	Max. unit weight 8.1 t	Max. unit weight 10.6 t
Shaft covers	Up to 1 x DN 1,000	Up to 2 x DN 800	Up to 2 x DN 1,000

Including

- Roof openings for shaft covers
- Coring for aeration pipe
- Sloped floor
- Sump pit with grating cover
- Concrete installation of well head or floor opening

Optional

- Shaft covers
- Uplift prevention
- Coring for pipelines and cable entry
- Domed covers/shaft domes
- Grounding connection
- Outside bitumen coating



Well shafts made of stainless steel DN 1,500, 2,000, 2,500 x 2,000 mm

Product description

Water pressure-tight well shafts made of stainless steel are resistant to aging and are characterized by their hygienically clean surface and low net weight combined with high stability.

Product characteristics

- Material: Stainless steel 1.4301/1.4307 (V2A) and 1.4571/1.4404 (V4A)
- Domed covers for entry and installation opening including stainless steel shaft covers (design based on customer request)
- Integrated aeration and ventilation stack DN 150
- Integrated safety riser pipe incl. entry aid
- Retaining bracket for electrical distribution
- Welded FF piece as wall duct for pipeworks pipe system
- Wall duct for electrical lines
- Sloped floor with sump pit or in-floor grating with floor outlet

Benefits

- Permanently water pressure-tight design
- Durable and resistant to aging
- Good handling on site due to low net weight
- Freely configurable interior construction
- Advantageous for hygiene purposes thanks to easily cleaned, smooth surfaces

Technical data

- Nominal widths: DN 1,500, DN 2,000, DN 2,500
- Inner height clearance: 2,000 mm, other heights on request!

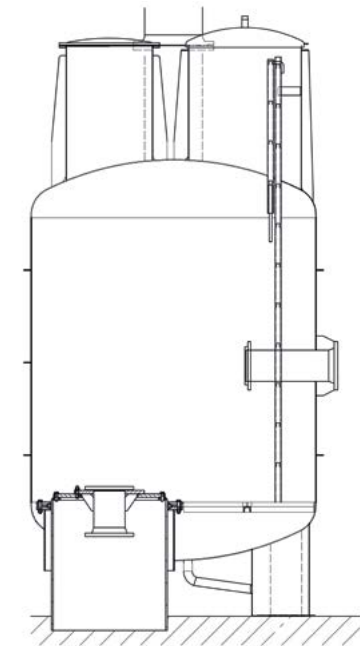
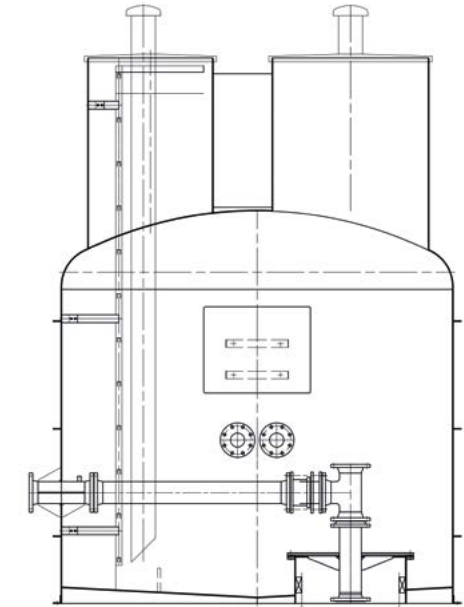

Well houses

Product description

GWE well houses combine technical benefits, such as occupational safety, accessibility and intrusion protection, with visual elegance. They are the above-ground alternative to classical well shafts.

Product characteristics and models

- Concrete: Waterproof concrete C35/45 according to DIN EN 206-1/DIN 1045-2
- Exposure class: XC4, XF3, XA1, without XD, without XM
- Moisture class: WA
- Reinforcing steel: B500A/B according to DIN 488
- Solid, semi-monolithic design made from reinforced concrete
- Internal and external surfaces in exposed concrete SB1
- Individually extendible, configurable basic versions

Benefits

- Turnkey structure including pipelines from a single source
- Fast and easy installation on a prepared platform
- Pre-assembly of pipe system in factory available
- Maintenance work can be carried out by one person (occupational safety)
- Minimized risk of accidents
- Engineering by GWE according to customer requirements

Technical data / Design

- Standard dimensions (inner clearance dimensions): 2.00 x 2.00 x 2.20 m or 3.00 x 2.00 x 2.20 m (Other dimensions available on request)
- 200 mm wall, floor and roof thickness
- Roof panel optionally available with tilted roof on all sides and drip edge, mono-pitch roof or flat basin roof with outlet and downpipe
- Installation opening in the roof panel, round DN 800/DN 1,000 or rectangular 800 x 800/1,000 x 1,000 mm

Optional additions

- Insulation of the external walls and roof in inside area as WDVS WLG 035 (adhesive, bolts, perimeter insulation d = 50 mm in the area of the base, EPS insulation plates d = 50 mm above the base) with external plaster (reinforcement plaster with tissue layer, finish coat fine plaster) incl. paint in RAL color tones
- External plaster incl. paint in RAL color tones
- Base area highlighted in different color
- Anti-graffiti protection for external walls
- Inside coating of walls and roof with silicate paint

- Door opening 1,010 x 2,000 mm with granite threshold and stainless steel safety door 1,000 x 2,000 mm TT2.1/RC3 with sliding ventilation blinds and internal insect screen, magnetic contact
- Sloping screed with sump pump
- Wall and floor openings based on technical requirements
- Well head encased in concrete at factory

- Full tiling in floor and/or wall area
- Anti-slip base coating in RAL color tones
- Grounding connection
- Floor outlet with odor trap and side connection socket DN 100 in external area of shaft base for wastewater pipe
- Additional ventilation blinds in wall area
- Other additional equipment by request



Design examples

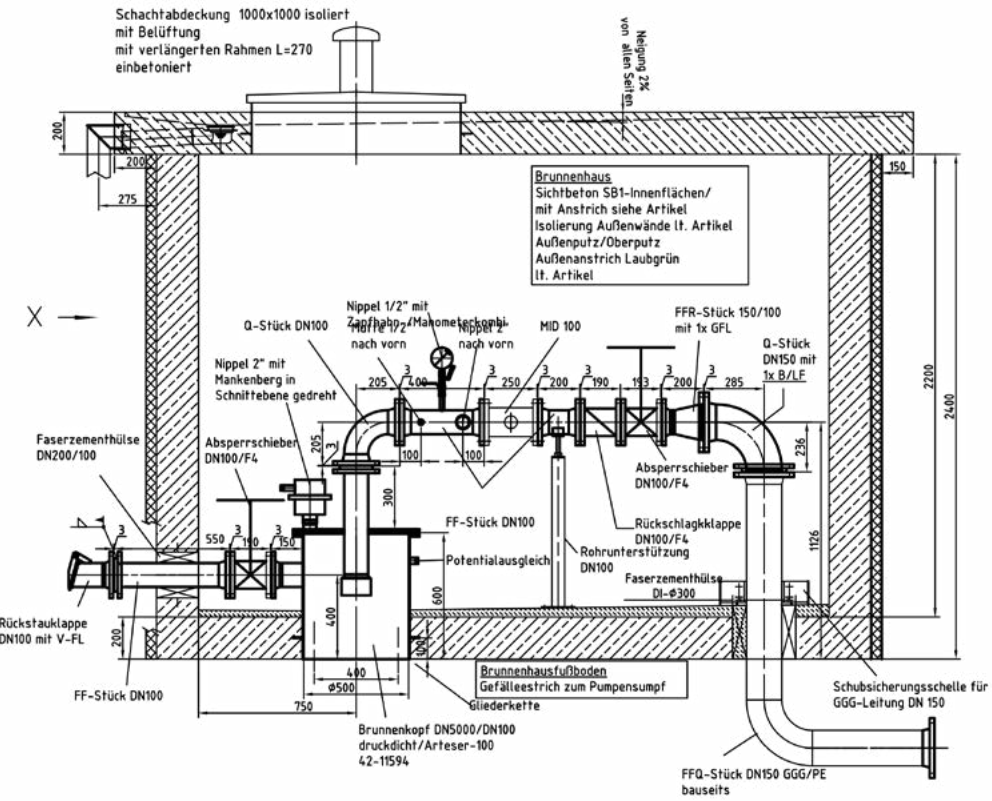

Version: 3.00 x 2.00 x 2.20 m with flat basin roof, outlet and downpipe Insulation of external walls as WDVS with fine plaster and external paint with base highlighted in different color. Turnkey delivery including pre-assembled pipeline components. Weight approx. 23 t

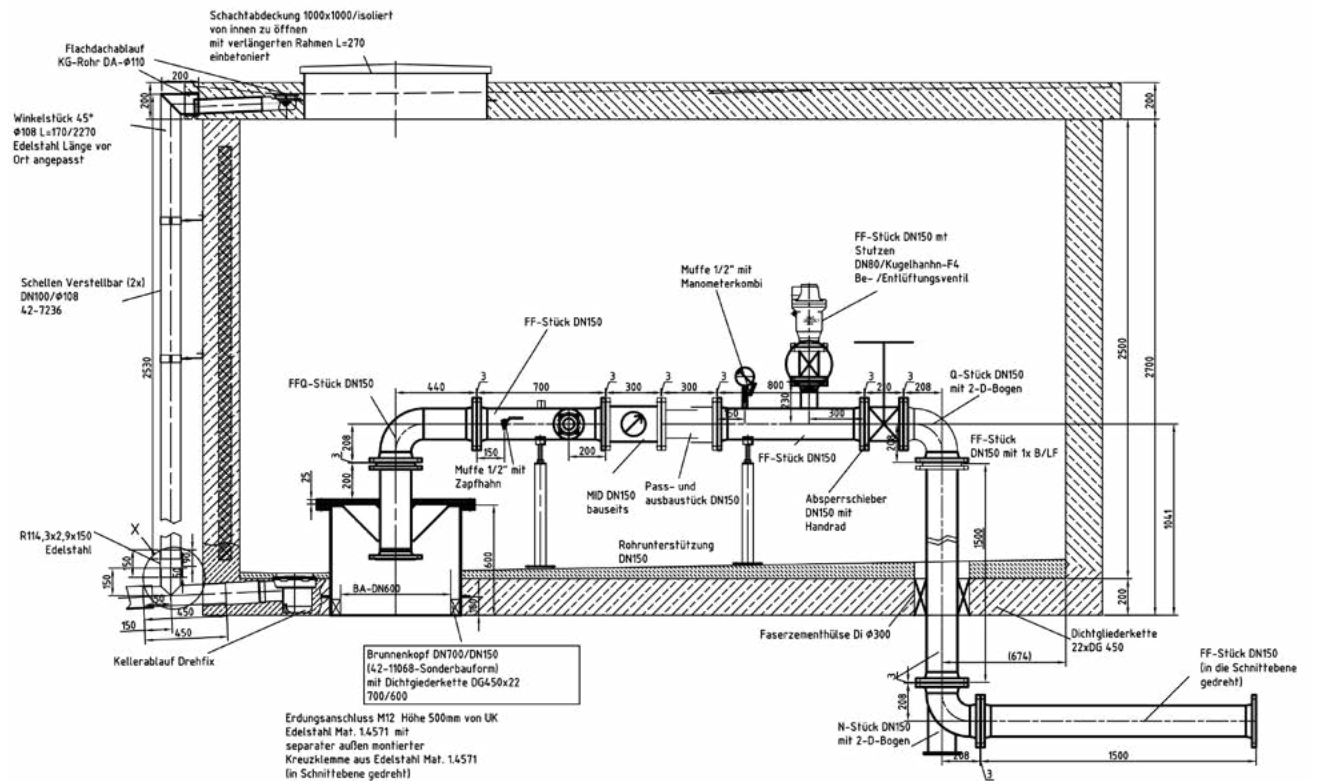

Version: 4.50 x 2.50 x 2.50 m with flat basin roof, outlet and downpipe Internal and external surfaces in exposed concrete quality SB1. Turnkey delivery including pre-assembled pipeline components. Weight approx. 35 t

Well hoods – GWE Well Hood

Product description

The GWE well hood is an above-ground well closure with pre-mounted well head and pipeworks pipe system.

Product characteristics

- The GWE well hood offers safe and reliable protection for wells and water collection systems in factories, sporting facilities and parks, as well as facilities for agricultural irrigation.
- With the GWE well hood, the well and the installed water fittings are protected against unauthorized access and against the penetration of surface water.
- The well hood is easy to open and close, requiring just one person for regular inspections and smaller repairs.
- Thanks to the double-walled housing and integrated heating, operations are guaranteed even in permafrost conditions.



Benefits

- CE label
- Rapid installation with pre-mounted well head and pipe system
- Strong protection against unauthorized opening (safety lock and additional padlock)
- Integrated control box in protection class IP65 (dustproof and impermeable)
- UV-resistant housing surface made of polyester-glass laminate (gel coat)

Basic equipment

- Well head with riser pipe connection DN 50 to DN 150 (Sizes: DN 50, DN 65, DN 80, DN 100, DN 125, DN 150)
- Pre-mounted pipeworks pipe system comprising:
 - Check valve
 - Pipe bend (Q piece)
 - Water meter
 - Throttle valve
 - Pressure gauge with valve
 - Thermostat-controlled 250 W heating

External dimension

L x W x H: 1,550 x 1,080 x 1,117 mm

Accessories

- Inductive flow rate meter
- Sampling valve
- Fire hydrant connection 2" (C-clutch)
- Customer logo, special colors

Additional equipment and further accessories possible after prior consultation.



Well hoods – WellCo® well hood

Product description

The GWE WellCo® well hood offers safe and reliable protection for wells and water collection systems in factories, sporting facilities and parks, as well as facilities for agricultural irrigation. With the GWE WellCo® well hood, the well and the installed water fittings are protected against unauthorized access and against the penetration of surface water.

Product characteristics

Thanks to its prefabricated design, the GWE WellCo® well hood can be installed quickly and efficiently in a very short construction period. Reduced costs for installation and streamlined work processes are an appealing alternative to large, heavy closure structures. The GWE WellCo® well hood is easy to open and close, requiring just one person for regular inspections and smaller repairs. Thanks to the double-walled housing and integrated heating, operations are guaranteed even in permafrost conditions.

Benefits

- CE label with declaration of conformity
- Short installation time due to prefabricated concrete base plate and integrated well head with pipe system
- Protection against unauthorized opening
- Frost protection thanks to heat insulation and radiator heating
- Integrated LED illumination
- Aeration system

Design

Base frame and roof made of aluminum sheet, circumferential aluminum angle profile with rubber seal in floor area of hood as floor sealing

- Aluminum insulation elements 60 mm thick, K value 0.42
- Gas pressure absorber as installation aid
- Central floor closure with hook lock
- Opening angle approx. 70 - 75° (after unlocking 90°)
- Two ventilation openings to prevent moisture



Technical data

Well head sizes DN 200 to DN 700
Riser pipe connection DN 40 to DN 150

Internal dimensions L x W x H: 2,000 x 900 x 1,000 mm

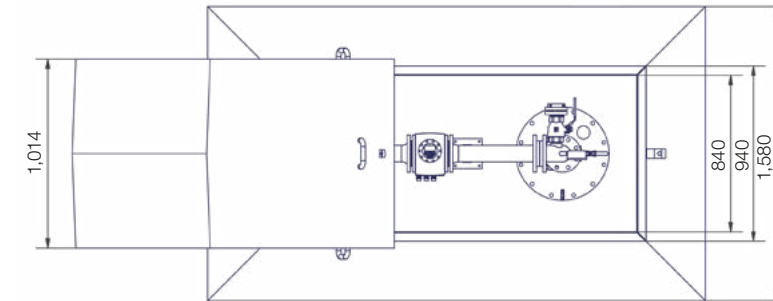

Accessories

- Pre-mounted pipeworks pipe system comprising:
 - Check valve
 - Q piece (pipe bend)
 - MID/Water meter
 - Isolation valves (gate valves/flap)
 - FF piece
 - Connection for pressure gauge and sampling valve
- Heating (finned pipe heating furnace) 500W
- LED interior illumination
- Socket
- Fire extinguisher/rinse connection

Other equipment available by request.

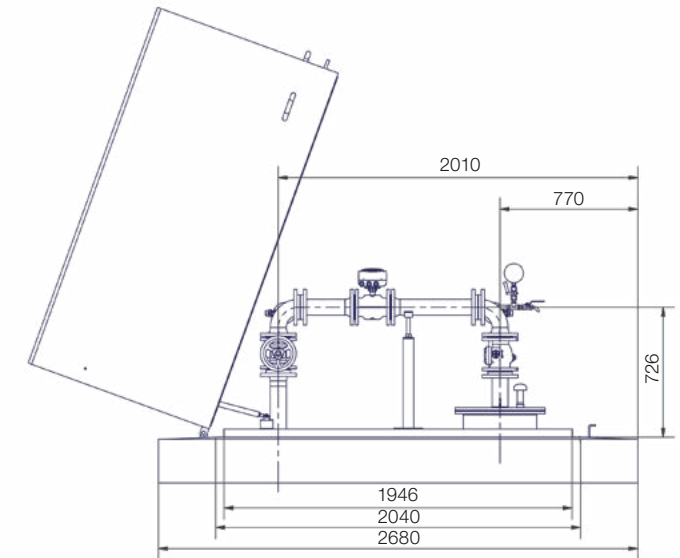

Accessories for well shafts and well houses – Stainless steel shaft covers

Product description

Steel cover in round (8-point) and square/rectangular design made of stainless steel according to DIN 1239, suitable for use in drinking water wells as well as wastewater areas.

Product characteristics

- Rainwater-tight, safe to walk on
- Material stainless steel 1.4301/1.4307 (V2A) or 1.4571/1.4404 (V4A)
- Lid of 2 mm thick stainless steel sheet, elevated in center
 - With self-activating lock
 - With integrated stop mechanism that can only be released manually, which prevents the lid from unintentionally falling shut
 - With stainless steel gas pressure spring
- Lid connected with the frame by interior hinges, lid can be detached from frame
- Frame made of angular profile for round version or Z profile for square/rectangular version
- With circumferential, frost-, insect- and weather-resistant rubber seal
- With internally welded loops for bolting that ensure an even contact area
- Connection for equipotential bonding available

Accessories

- Universal operating key for hexagonal and oval cap
- Foam rubber seal
- Mounting material

Optional

- Vapor hood with insect screen DN 150
- Insulation for lid, CFC-free
- Mortise safety lock with locking cylinder
- Magnetic contact
- Reinforced lid sheet s = 4 mm (intrusion-resistant)
- Frame drilled for bolting on the shaft roof
- Extended base frame with wall flange for concrete installation

Notes

We point out that according to DVGW worksheet W122 "Closure structures for water extraction wells" as well as BGV C 5 "Technical wastewater systems," the clearance width of entry openings must be at least 800 mm!

Please also note the additional versions, for example flood-safe shaft covers, in our portfolio.



Technical data

Circular model (8-point)	Ø shaft opening (inside) (mm)	Inside clearance (mm)	External dimensions of the base frame (mm)	Weight (kg)
Without vapor hood Without insulation	600	505 mm	672 mm	18.5
	700	605 mm	772 mm	21.5
	800	705 mm	872 mm	29.5
With vapor hood Without insulation	1,000	905 mm	1,095 mm	43.0
	600	505 mm	672 mm	22.0
	700	605 mm	772 mm	25.0
Without vapor hood With insulation	800	705 mm	872 mm	33.0
	1,000	905 mm	1,095 mm	46.5
	600	505 mm	672 mm	22.5
With vapor hood With insulation	700	605 mm	772 mm	27.5
	800	705 mm	872 mm	32.5
	1,000	905 mm	1,095 mm	59.0
Without vapor hood Without insulation	600	505 mm	672 mm	27.0
	700	605 mm	772 mm	31.5
	800	705 mm	872 mm	36.0
With vapor hood With insulation	1,000	905 mm	1,095 mm	63.0

Square / rectangular model	Ø shaft opening (inside) (mm)	Inside clearance (mm)	External dimensions of the base frame (mm)	Weight (kg)
Without vapor hood Without insulation	600 x 600	505 mm	740 mm x 740 mm	25.7
	700 x 700	605 mm	840 mm x 840 mm	28.3
	800 x 800	705 mm	940 mm x 940 mm	32.4
With vapor hood Without insulation	1,000 x 1,000	905 mm	1,140 mm x 1,140 mm	47.5
	600 x 600	505 mm	740 mm x 740 mm	29.3
	700 x 700	605 mm	840 mm x 840 mm	32.3
Without vapor hood With insulation	800 x 800	705 mm	940 mm x 940 mm	36.0
	1,000 x 1,000	905 mm	1,140 mm x 1,140 mm	45.3
	600 x 600	505 mm	740 mm x 740 mm	30.1
With vapor hood With insulation	700 x 700	605 mm	840 mm x 840 mm	33.7
	800 x 800	705 mm	940 mm x 940 mm	39.6
	1,000 x 1,000	905 mm	1,140 mm x 1,140 mm	57.8
Without vapor hood Without insulation	600 x 600	505 mm	740 mm x 740 mm	34.0
	700 x 700	605 mm	840 mm x 840 mm	37.8
	800 x 800	705 mm	940 mm x 940 mm	42.8
With vapor hood With insulation	1,000 x 1,000	905 mm	1,140 mm x 1,140 mm	62.0

Custom dimensions/customized products on request.

Accessories for well shafts and well houses – GWE aeration stack

Product description

Stainless steel aeration stack for installation in well shafts and well structures for aeration and ventilation.

Product characteristics

- Material: Stainless steel 1.4301/1.4307 (V2A) or 1.4571/1.4404 (V4A)
- Fully welded under protective gas, stained and passivated in dip tank
- With welded insect screen, mesh size 1 x 1 mm
- Welded hood
- Freely selectable mounting options
 - Without additional mounting flange
 - Wall flange
 - Dowel flange
 - Arched flange with seal and pipe sheath for concrete installation
- Apart from standard structural lengths, custom lengths also possible



Technical data

Dimensions: DN 100 Ø 108/114.3 x 2.0 mm
 DN 150 Ø 154 x 2.0 mm (Standard)
 DN 200 Ø 219.1 x 2.0 mm

Structural length: 1,000/1,500/2,000/2,500/3,000/3,500/4,000 mm
 We manufacture different structural lengths individually for specific orders.

Optional accessories

- Adjustable mounting clamp for wall mounting
- Insertable pipe fan

Other models on request, e.g. for lateral wall installation.

Accessories for well shafts and well houses – Stainless steel riser pipes

Product description

Stainless steel riser pipes, stationary, designed according to DIN 3620 and UVV-VGB 74

Product characteristics

- Material: Stainless steel 1.4571
- Rails made of rectangular profile 40 x 20 mm
- Rungs made of perforated C-profile 23 x 30 x 2 mm
- Step width 300/400/500 mm
- Rung distance 280 mm
- Wall bracket permanently welded on, optionally in adjustable design



Benefits

- Corrosion-resistant
- Slip-proof rungs for secure step
- Quick installation

Technical data

Size	Largest shaft depth (mm)	Ladder length L3 (mm)	Number of rungs	Wall brackets
1	1,500	1,220	5	4
2	1,780	1,500	6	4
3	2,060	1,780	7	4
4	2,340	2,060	8	4
5	2,620	2,340	9	4
6	2,900	2,620	10	6
7	3,180	2,900	11	6
8	3,460	3,180	12	6
9	3,740	3,460	13	6
10	4,020	3,740	14	6
11	4,300	4,020	15	6
12	4,580	4,300	16	6
13	4,860	4,580	17	6

Accessories

- Including mounting material
- Access aid, attachable (double rail) as extra
- Access aid, foldaway (double rail) as extra
- Access aid, extendible (single rail) as extra

Additional design with fall protection railing and custom solutions on request.



9. Geothermal energy

Product overview	222
Specialist knowledge	224
Compact shafts	226
Shafts for commercial use GEO shafts	230
GWE geothermal energy special shafts	235
GWE EWS duplex probe	236
GWE OptiFlow® N	238
Accessories	239



Access current information about the product area online

Geothermal energy shafts

	Fixbox	Mono 400	Mono 612	Mono 695	Geo 450 H	Geo 800 H	Geo 940 H	Geo 1225 H	Geo 1500 H
Product									
Product type	Outlets 2–4	Outlets 2–3	Outlets 2–6	Outlets 7–10	Outlets 2–4	Outlets 2–10	Outlets 2–10	Outlets 7–28	Outlets 13–28
	400 mm x 450 mm x 400 mm	400 mm x 750 mm (Fixed height)	612 mm x 800 mm (Fixed height)	695 mm x 800 mm (Fixed height)	450 mm x 600–750 mm (Variable height)	800 mm x 1,060–1,360 mm (Variable height)	940 mm x 1,100–1,400 mm (Variable height)	1,225 x 1,410–1,710 mm (Variable height)	1,500 mm x 1,500–1,800 mm (Variable height)
	Inline setter + ball valve	Inline setter + ball valve	Inline setter + ball valve	Inline setter + ball valve	Inline setter + ball valve	Inline setter + ball valve	Inline setter + ball valve	Inline setter + ball valve	Inline setter + ball valve Main isolation
Application	Single-family home, foot traffic	Single-family home – A 15, foot traffic	Single-family home Apartment building	Apartment building Small commercial and services building	Single-family home – A15, vehicle traffic	Apartment building Small commercial and services building	Apartment building Small commercial and services building	Commerce, services, industry	Commerce, services, industry
			Foot traffic up to 200 kg (Optional wheel load up to 600 kg)	Foot traffic up to 200 kg (Optional wheel load up to 600 kg)		From foot traffic to vehicle traffic (A15–1.5 t/ B125–12.5 t/ D400–40 t)	From foot traffic to vehicle traffic (A15–1.5 t/ B125–12.5 t/ D400–40 t)	From foot traffic to vehicle traffic (A15–1.5 t/ B125–12.5 t/ D400–40 t)	From foot traffic to vehicle traffic (A15–1.5 t/ B125–12.5 t/ D400–40 t)
Product benefits	Low costs	Resisting uplift when in suitable depth	Resisting uplift when in suitable depth	Resisting uplift when in suitable depth	Resisting uplift when in suitable depth	Resisting uplift when in suitable depth	Resisting uplift when in suitable depth	Resisting uplift when in suitable depth	Resisting uplift when in suitable depth
	Low weight	Low costs	Low costs	Low costs	Greater installation depths	Low costs	Low costs	High flexibility	High flexibility
	Compact design	Low weight	Low weight	Low weight	Low weight	Low weight	Low weight		
		Compact design							

Geothermal energy, a crucial element of the energy revolution

Geothermal energy is an important component of the energy and heat revolution. Not only is it gentle on the landscape, climate-friendly and inexhaustible from a human perspective, it also enables reliable and safe energy supply at stable prices. Geothermal energy is always available and independent of the weather. With the technologies that have already been developed, the potential of geothermal energy can be harnessed nearly anywhere.

Near-surface geothermal energy uses the subsoil up to a depth of approx. 400 m and temperatures up to 25 °C for heating and cooling buildings, technical systems or infrastructure equipment. To this end, heating or cooling energy is extracted from the groundwater or upper earth and rock layers and brought to a different temperature level using heat pumps. Apart from the classical application to provide room heating and warm water, near-surface geothermal energy is also used to heat greenhouses as well as for de-icing parking lots, railway lines and track switches.

GWE is a certified manufacturer of PE geothermal probes as well as various coaxial probe systems made of different materials. With our extensive know-how and many years of experience, we optimize existing systems and develop new solutions for heat production.

In addition to the manufacture of geothermal system components, we design, develop, and implement holistic geothermal energy solution systems together with our partner companies. In addition to the manufacture of special products and components that improve and simplify site processes, the focus of our actions is on the economic and ecological benefit for our clients and design partners.

GWE geothermal energy products are manufactured and certified according to the latest standards, such as VDI 4640, DVGW and SKZ.

Near-surface geothermal energy

Technical benefits

- **Constant output** In contrast to solar or wind energy, the output of near-surface geothermal energy is independent of weather conditions or time of day. Geothermal energy is available year around and remains stable, which enables continual heating or cooling.
- **Compact installation:** Installation in near-surface geothermal energy systems generally requires less space than other renewable energy sources, such as solar plants or wind turbines. The geothermal probes or collectors can be installed or positioned on small properties or even in urban areas.
- **Long-term reliability:** Geothermal systems have a long service life and require little maintenance compared with conventional heating or cooling systems. The geothermal probes or collectors are very durable and can be used for decades.
- **Low environmental impact:** Near-surface geothermal energy has a significantly lower environmental impact compared to fossil-based heating and cooling systems. The operation of geothermal energy pumps leads to a reduction in greenhouse gas emissions and helps to reduce the environmental footprint.
- **Synergies with renewable energy:** Near-surface geothermal energy can be combined with other renewable energy sources. For example, the heat energy from geothermal systems can be used to assist solar energy plants with supplying warm water.

Economic benefits

- **Cost savings:** By using geothermal energy pumps for heating and cooling buildings, considerable cost savings can be achieved. Compared with conventional heating systems, the operating costs can be reduced by up to 50%. These savings result from the use of free, renewable heat energy from the ground.
- **Long-term cost security:** The costs for fossil fuels such as natural gas or heating oil can be subject to heavy fluctuations, while heat energy from near-surface geothermal energy is constant and stable. This means long-term cost security for operators of geothermal systems.
- **Energy independence:** By using natural geothermal energy, building owners can reduced their dependence on external energy providers. This is particularly advantageous in light of rising energy prices and potential supply interruptions.
- **Environmental benefits:** Apart from the commercial benefits, near-surface geothermal energy also offers considerable environmental benefits. By reducing the use of fossil fuels, greenhouse gas emissions are reduced and environmental sustainability is promoted.

Technisches Datenblatt
GWE Kompaktschacht 400

Produktbeschreibung
Kompakter Rundschaft für die Unterbringung von bis zu 3 Sondenkreisen. Einsetzbar überall dort, wo keine Befahrbarkeit erforderlich ist und wenig Platz für die Unterbringung eines größeren Kompaktschacht zur Verfügung steht. Sehr gut geeignet im Bereich von Einfamilienhäusern.

Produkteigenschaften

- Standardausführung 2 bis 3 Sondenkreise
- Platzsparend
- Verkehrslast A15

Vorteile

- Komplett geprüfte Baugruppe mit Regelventilen und Absperrarmaturen.
- Anschlüsse normgerecht und spannungsfrei verschweißt.
- Auftriebsschutz durch speziell geformte Bodenplatte.
- Erbauzeitige Lieferung auf die Baustelle.
- Problemlose Installation von 1 Person möglich.

Technische Daten

Werkstoff	PEHD
Dimension (Schachtkörper Ø x H) in mm	400 x 750
Bodenplatte (L x B) in mm	500 x 500
Anschluss EWS	DA 40
Anschluss Wärmepumpe	DA 63
Armatur Vortlauf	Kugelhahn DN 20
Armatur Rücklauf	Inline-Setter 8 - 38 l/min
Zusatzarmaturen	je ein Kugelhahn DN 20 zum Befüllen, Entlüften und A15-Verkehrsfächchen, die von Fußgängern/Radfahrern benutzt werden können. Auch Grünflächen geeignet. Fahrzeuglasten bis 600 kg möglich.

Weitere Sonderlösungen nach Absprache möglich.

Zubehör (optional):

- Inline-Setter 2 - 12 l/min, 5 - 42 l/min.
- Abgänge DA 25 oder DA 32

Technische Änderungen vorbehalten.
Alle Angaben ohne Gewähr.

Kontakt
Tel.: +49 5171 294-0, Mail: info@gwe-gruppe.de, Web: www.gwe-gruppe.de

Technisches Datenblatt
GWE EWS-Duplexsonde DA32

Produktbeschreibung:
GWE Duplex Erdwärmesonden DA32 werden aus hochwertigem PE 100 RC Material hergestellt. Die Erdwärmesonden werden vorkonfektioniert geliefert und dienen zur Gewinnung geothermischer Energie mit zwei Sondenkreisen. Der Sondenfuß wird mit einem dafür eigens entwickelten Schweißautomaten mit dem RC-Sondenrohr dauerhaft verbunden. Die Verschweißung wird von ausgebildeten Schweißpersonal durchgeführt. Die Produktion der GWE Erdwärmesonden wird von der IMA Materialforschung und Anwesenheit Prüfzelle von DVGW, DIN CERTCO und DIBt entsprechend der SKZ-Richtlinie HR 3.26 freigegeben, und zertifiziert durch das SKZ Würzburg und erfüllen alle gängigen Normen.

Sondenfuß mit Zubehör für Sondengewicht:

Die Abbildung zeigt den Duplex-Sondenfuß mit eingesteckter und verschraubter Einstocktasche zur festen Abbindung eines GWE-Sondengewichts.

Produkteigenschaften:

- Standardausführung Duplex DA32
- Verstärkte Wandung im Sondenfuß für höhere Belastbarkeit
- Schlanke Design für kleine Bohrdurchmesser und schnellen Einbau
- Minimaler Druckverlust durch großen Querschnitt im Sondenfuß

ZERTIFIKAT

Die SKZ - Testing GmbH verleiht der unten stehenden Firma das Recht zur Führung des SKZ Prüf- und Überwachungszeichens

Zeichen-Inhaber GWE GmbH Moorbeerenweg 1 31228 Peine Deutschland	Hersteller System --- Sonde GWE GmbH Rohre GWE GmbH Sondenfüße GWE GmbH Formteile --- Verbinder --- Verteiler ---
Prüfrichtlinien SKZ Prüf- und Überwachungsbestimmung HR 3.29/2015-02	Produkt Erdwärmesonden aus Polyethylen, PE 100 RC, für Erdwärmeprodukte d. s. 63 mm bestehend aus Rohren und Sondenfüßen aus PE 100 RC, werkseitig geschweißt

A 795

Erstverleihung ---

Gültigkeitsdauer
14. April 2024

Mit der Führung des SKZ Zeichens ist die Verpflichtung verbunden, bei der Herstellung und Prüfung der Erzeugnisse die vorgegebenen Bestimmungen einzuhalten.

Würzburg, 17. Februar 2022/

SKZ
Nationaler Überwachungs- und Prüfverband

SKZ
SKZ - Testing GmbH, Friedrich-Bergius-Ring 22, 97076 Würzburg, Germany, Tel.: +49 931 4154-0, testing@skz.de, www.skz.de

Compact shafts – Geothermal shaft GWE Fixbox

Product description

GWE FixBox – The compact distribution shaft made of PE 100 for connection of 2–4 geothermal probes to residential buildings.

Product characteristics

- Highly compact design
- Lockable
- Can be positioned on or in the building

Benefits

- Installation underground possible, so no construction measures are needed for buildings without a cellar.
- Direct wall installation in the area of the wall passthrough is possible, so there is no need for time-consuming and difficult installation of distribution fittings in light shafts
- Completely water pressure-tight
- Fittings and pipe passages are optimally coordinated and welded tension-free
- Ready-to-install delivery to the site
- Installation can be carried out by 1 person without any problem

Technical data

Material	HDPE 100 (high-density polyethylene)
Dimensions (H x L x W) in mm	450 x 390 x 390
Equipment	Distribution beam for 2–4 probes
Probe connection	DA 40
Heat pump connection	DA 63
Fitting forward flow	Ball valve DN 25
Fitting return flow	Inline setter 8–38 l/min
Additional fittings	One ball valve each DN 25-1" female thread for filling, ventilating, emptying
Traffic load/coverage	Foot traffic up to max. 200 kg

Accessories (optional)

- Wall installation set
- Electro-welding formed parts

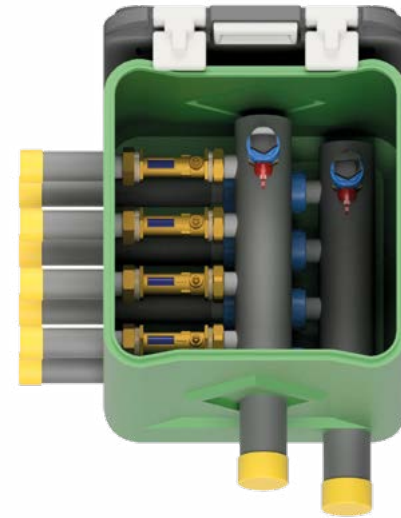

Compact shafts – GWE compact shaft 400

Product description

Compact circular shaft for accommodation of up to 3 probe circuits. Can be used anywhere it is necessary for the system to support vehicle traffic and little space is available for accommodating a larger compact shaft. Very well suited in the area of single-family homes.

Product characteristics

- Standard model 2 to 3 probe circuits
- Compact
- Traffic load A15

Benefits

- Completely tested component groups with control valves and isolation fittings
- Connections welded according to standard and tension-free
- Uplift protection through specially shaped floor plate
- Ready-to-install delivery to the site
- Installation can be carried out by 1 person without any problem

Technical data

Material	PEHD
Dimension (shaft body Ø x H) in mm	400 x 750
Floor plate (L x W) in mm	500 x 500
Probe connection	DA 40
Heat pump connection	DA 63
Fitting forward flow	Ball valve DN 20
Fitting return flow	Inline setter 8–38 l/min
Additional fittings	One ball valve DN 20 each for filling, ventilating
Traffic load/coverage	A15 traffic areas that can be used by pedestrians and cyclists Also suitable for green spaces. Bicycle load up to 600 kg possible.

Other custom solutions possible by consultation.

Accessories (optional)

- Inline setter 2–12 l/min., 5–42 l/min.
- Outlets DA 25 or DA 32



Compact shafts – GWE compact shaft 612

Product description

Compact circular shaft for accommodation of up to 6 probe circuits. Can be used anywhere it is necessary for the system to support vehicle traffic and little space is available for accommodating the fittings.

Product characteristics

- Standard model 2 to 6 probe circuits
- Only single-sided design of probe outlets is possible
- 2 solutions are available for traffic loads

Benefits

- Completely tested component groups with control valves and isolation fittings
- Connections welded according to standard and tension-free
- Uplift protection through specially shaped floor plate
- Ready-to-install delivery to the site

Technical data

Material	PEHD
Dimension (shaft body Ø x H) in mm	612 x 800
Floor plate (L x W) in mm	750 x 750
Probe connection	DA 40
Heat pump connection	DA 63
Fitting forward flow	Ball valve DN 25 made of plastic with thread connection
Fitting return flow	Inline setter 5–42 l/min made of plastic with thread connection
Additional fittings	One ball valve DN 25 (1" female thread) each for filling, ventilating
Traffic load/coverage	Stabiflex 200 – foot traffic up to 200 kg Stabiflex 600 – foot traffic/wheel load up to max. 600 kg

Accessories (optional)

- Various fittings, e.g. TacoSetter Bypass, Watt Flow, Hydrocontrol, thermometer etc.
- Custom solutions possible by consultation such as main isolation in the form of ball valve 1 1/2"

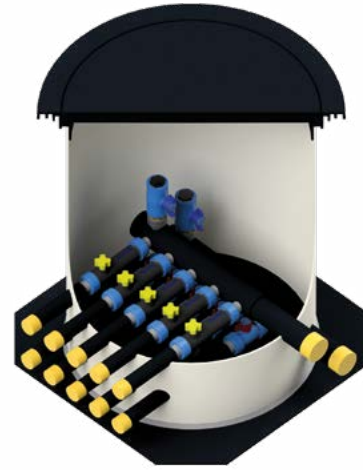

Compact shafts – GWE compact shaft 695

Product description

Compact circular shaft for accommodation of up to 10 probe circuits. Can be used anywhere it is necessary for the system to support vehicle traffic and little space is available for accommodating the fittings.

Product characteristics

- Standard model 7 to 10 probe circuits
- Probe outlets on both sides
- Additionally, a main isolation as ball valve
- 1–1/2" is possible
- 2 solutions are available for traffic loads

Benefits

- Completely tested component groups with control valves and isolation fittings
- Connections welded according to standard and tension-free
- Uplift protection through specially shaped floor plate
- Ready-to-install delivery to the site

Technical data

Material	PEHD
Dimension (shaft body Ø x H) in mm	695 x 800
Floor plate (L x W) in mm	750 x 750
Probe connection	DA 40
Heat pump connection	DA 75
Fitting forward flow	Ball valve DN 25
Fitting return flow	Inline setter 5–42 l/min
Additional fittings	One ball valve each DN 25 (1" female thread) for filling, ventilating, emptying
Traffic load/coverage	Stabiflex 200 – foot traffic up to 200 kg Stabiflex 600 – foot traffic/wheel load up to max. 600 kg

Accessories (optional)

- Various fittings, e.g. TacoSetter Bypass, Watt Flow, Hydrocontrol etc.
- Custom solutions by consultation

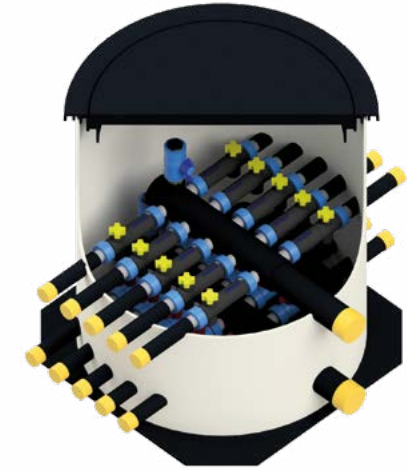

Shafts for commercial use GEO shafts – GWE compact shaft Geo 450

Product description

Compact circular shaft for accommodation of up to 4 probe circuits. Can be used anywhere it is necessary for the system to support occasional vehicle traffic and little space is available for accommodating a larger GEO shaft.

Product characteristics

- Standard model 2 to 4 probe circuits
- With up to 3 probe circuits, a main isolation as ball valve 1-1/2" is also possible
- Traffic load A15

Benefits

- Completely tested component groups with control valves and isolation fittings
- Connections welded according to standard and tension-free
- Uplift protection through specially shaped floor plate
- Ready-to-install delivery to the site
- Installation can be carried out by 1 person without any problem

Technical data

Material	PEHD
Dimension (shaft body Ø x H) in mm	450 x 550 to 450 x 750
Floor plate (L x W) in mm	560 x 560
Probe connection	DA 40
Heat pump connection	DA 63
Fitting forward flow	Ball valve DN 20
Fitting return flow	Inline setter 8–38 l/min
Additional fittings	One ball valve DN 20 each for filling, ventilating
Traffic load/coverage	A15 traffic areas that can be used by pedestrians and cyclists Also suitable for green spaces. Bicycle load up to 600 kg possible

Accessories (optional)

- Various fittings, e.g. TacoSetter Bypass, Hydrocontrol
- Custom solutions possible by consultation



Shafts for commercial use GEO shafts – GWE geothermal shaft Geo 800

Product description

The interface between compact and GEO shafts. Thanks to its size, the Geo 800 is a solution for compact shafts 612 and 695 with the options of a GEO shaft. The dome cover enables lid loads up to KLD 400. The compact size facilitates installation on the site.

Product characteristics

- Standard model up to 8 probe circuits
- Additionally, a main isolation as ball valve or with shut-off valve is possible
- Various solutions are available for all traffic loads

Benefits

- Height-adjustable dome cover for alignment to the ground level
- Completely tested component groups with control valves and isolation fittings
- Connections welded according to standard and tension-free
- Uplift protection through specially shaped floor plate
- Ready-to-install delivery to the site

Technical data

Material	PEHD
Dimension (shaft body Ø x H) in mm	810 x 1,060 to 810 x 1,360
Floor plate (L x W) in mm	930 x 930
Probe connection	DA 40
Fitting forward flow	Plastic ball valve DN 25
Fitting return flow	Plastic inline setter 5–42 l/min
Additional fittings	One ball valve DN 25 each for filling, ventilating etc.
Traffic load/coverage (standard)	A15 – loads up to 1,500 kg – height-adjustable from 130 mm to 430 mm

Accessories (optional)

- Shaft covers: KLB125 (vehicle traffic); KLD400 (truck traffic).
- Various fittings, e.g. TacoSetter Bypass, Hydrocontrol, thermometer, pressure gauge etc.

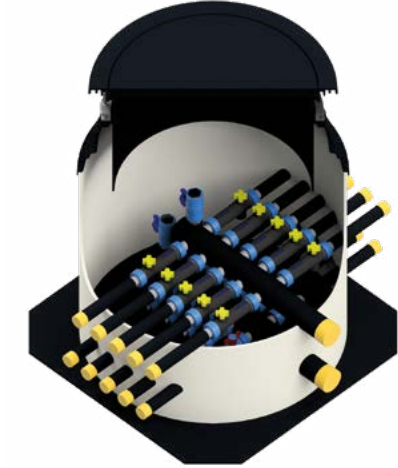

Shafts for commercial use GEO shafts – GWE geothermal shaft Geo 940

Product description

The flexible system for all applications. The Geo 940 offers solutions for various installation situations. This facilitates installation on the site.

Product characteristics

- Standard model up to 10 probe circuits
- Additionally, a main isolation as ball valve up to 2" or with shut-off valve up to DN 65 is possible
- Various solutions are available for all traffic loads

Benefits

- Height-adjustable dome cover for alignment to the ground level
- Completely tested component groups with control valves and isolation fittings
- Connections welded according to standard and tension-free
- Uplift protection through specially shaped floor plate
- Ready-to-install delivery to the site

Technical data

Material	PEHD
Dimension (shaft body Ø x H) in mm	940 x 1,100 to 940 x 1,400
Floor plate (L x W) in mm	1,000 x 1,000
Probe connection	DA 40
Fitting forward flow	Ball valve DN 25
Fitting return flow	Inline setter 5–42 l/min
Additional fittings	One ball valve each DN 25 (1" female thread) for filling, ventilating, emptying
Traffic load/coverage (standard)	A15 – loads up to 1,500 kg – height-adjustable up to 130–430 mm

Accessories (optional)

- Various shaft covers: KLB125 (vehicle traffic), KLD400 (truck traffic)
- Various fittings, e.g. TacoSetter Bypass, Watt Flow, Hydrocontrol etc.
- Custom solutions by consultation

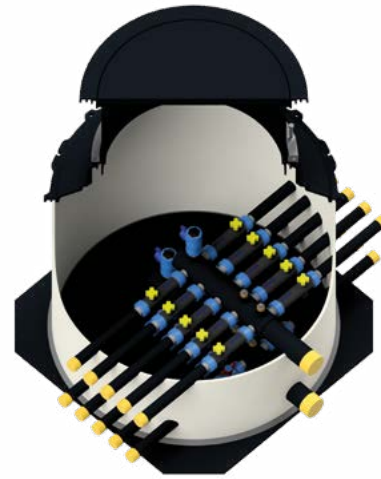

Shafts for commercial use GEO shafts – GWE geothermal shaft GEO 1225

Product description

The flexible system for all applications. The Geo 1225 offers solutions for various installation situations. This facilitates installation on the site.

Product characteristics

- Standard model up to 16 probe circuits in a single-row model and up to 28 probe circuits in double-row model
- Additionally, a main isolation with shut-off valve from DN 65 to DN 125 is possible
- Various solutions are available for all traffic loads

Benefits

- Height-adjustable dome cover for alignment to the ground level
- Completely tested component groups with control valves and isolation fittings
- Connections welded according to standard and tension-free
- Uplift protection through specially shaped floor plate
- Ready-to-install delivery to the site

Technical data

Material	PEHD
Dimension (shaft body Ø x H) in mm	1,225 x 1,410 to 1,225 x 1,710
Floor plate (L x W) in mm	1,500 x 1,500
Probe connection	DA 40
Fitting forward flow	Ball valve DN 25
Fitting return flow	Inline setter 5–42 l/min
Additional fittings	One ball valve each DN 25 (1" female thread) for filling, ventilating, emptying
Traffic load/coverage (standard)	A15 – loads up to 1,500 kg – height-adjustable up to 130–430 mm

Accessories (optional)

- Shaft covers: KLB125 (vehicle traffic), KLD400 (truck traffic)
- Various fittings, e.g. TacoSetter Bypass, Watt Flow, Hydrocontrol, thermometer, pressure gauge, automatic ventilator
- Custom solutions by consultation



Shafts for commercial use GEO shafts – GWE geothermal shaft GEO 1500

Product description

The flexible system for all applications. The Geo 1500 offers solutions for various installation situations. This facilitates installation on the site.

Product characteristics

- Standard model up to 22 probe circuits in a single-row model and up to 28 probe circuits in double-row model
- Additionally, a main isolation with shut-off valve from DN 65 to DN 150 is provided
- Various solutions are available for all traffic loads

Benefits

- Height-adjustable dome cover for alignment to the ground level
- Completely tested component groups with control valves and isolation fittings
- Connections welded according to standard and tension-free
- Uplift protection through specially shaped floor plate
- Ready-to-install delivery to the site

Technical data

Material	PEHD
Dimension (shaft body Ø x H) in mm	1,225 x 1,410 to 1,225 x 1,710
Floor plate (L x W) in mm	1,500 x 1,500
Probe connection	DA 40
Fitting forward flow	Ball valve DN 25
Fitting return flow	Inline setter 5–42 l/min
Additional fittings	One ball valve each DN 25 (1" female thread) for filling, ventilating, emptying
Traffic load/coverage (standard)	A15 – loads up to 1,500 kg – height-adjustable up to 130–430 mm

Accessories (optional)

- Shaft covers: KLB125 (vehicle traffic), KLD400 (truck traffic)
- Various fittings, e.g. MS Inline Setter, TacoSetter Bypass, Watt Flow, Hydrocontrol, thermometer, pressure gauge, automatic ventilator
- Custom solutions by consultation

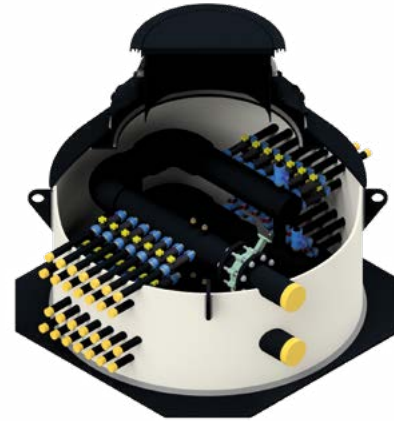

GWE geothermal energy special shafts

Product description

GWE special shafts offer the customer a high degree of flexibility for all applications and structural requirements. The system is flexible and works with every conceivable design. The shafts are only limited by structural requirements. In all cases, coverages from A15 walk-over to D400 for truck traffic are possible.

Product characteristics GWE winding pipe shafts

- Material: PEHD winding pipe
- Diameter: DN 1,500 to DN 2,000
- Length: According to structural requirements related to the number of probes, connections and fittings

Product characteristics GWE concrete shaft

- Concrete: C 35/45 according to DIN EN, 206-1/DIN 1045-2
- Exposure class: XC4, XF3, XA1
- Exposure class: Without XD, without XM
- Moisture class: WA
- Reinforcing steel: B500A/B according to DIN 488
- Load class: SLW60 according to DIN 1072
- Wall thickness: 200 mm
- Ceiling and floor thickness: 250 mm

The layout is based on the owner's requirements.

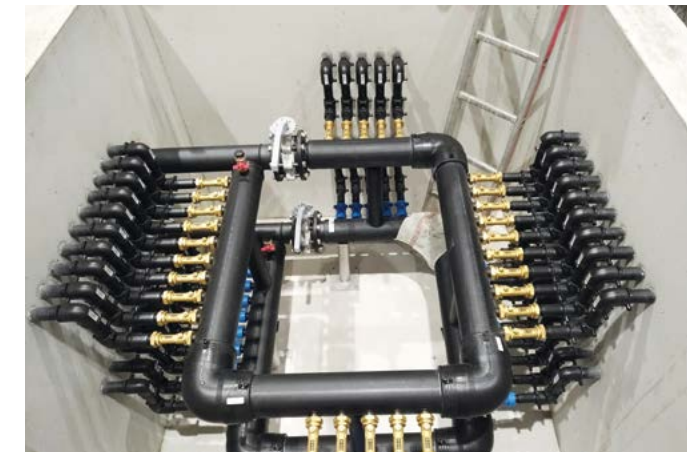

GWE EWS duplex probe

Product description

GWE Duplex geothermal probes are produced from high-quality PE 100 RC material. The geothermal probes are delivered pre-assembled and serve to extract geothermal energy with two brine circuits.

The probe foot is permanently connected with the RC probe tube using an automatic welding machine individually developed for this purpose. The welding is carried out by trained welders.

The production of GWE geothermal probes is externally monitored in Dresden by Applus-IMA Materialforschung und Anwendungstechnik GmbH, a recognized inspection authority for DVGW, DIN CERTCO and DIBt according to SKZ Directive HR 3.26. The probes are certified by SKZ Würzburg and fulfill all common standards.



Geothermal energy probe system

Probe foot with accessories for probe weight

The figure shows the Duplex probe foot with inserted and bolted insert lug for the fixed connection of a GWE probe weight.



Geothermal probe foot with insert lug for probe weight

Product characteristics

- Standard model Duplex DA 32, DA 40
- Reinforced walls in probe foot for enhanced durability
- Slim design for small borehole diameter and fast installation
- Minimal pressure loss thanks to large cross-section in probe foot

Benefits

- Completely pressure-tested component groups
- Connections welded according to standard
- Force conducting plate for installation with drill string
- Insert lug for bolting of probe weights without sway
- Ready-to-install delivery to the site



Geothermal probe foot

Technical data*

	Polyethylene 100 RC	Polyethylene 100 RC
Material	Polyethylene 100 RC	Polyethylene 100 RC
Dimension in mm	DA 32	DA 40
Diameter-wall thickness ratio (Standard Dimension Ratio = SDR)	SDR 11	SDR 11
Internal diameter in mm	740	800
Installation diameter for duplex probe	150 mm (6")	150 mm (6")
Connection to manifold	With electro-welding joint	With electro-welding joint
Nominal pressure	16 bar	16 bar
Probe foot diameter	100 mm	120 mm
Probe pipe diameter	32 x 3.0 mm	40 x 3.7 mm
Lengths	40–160 m in 10 m intervals	50–200 m in 10 m intervals
Grouting pipe d 25 (internal Ø, lengths)	Lengths: as needed Internal Ø: ≥ 740 mm	Lengths: as needed Internal Ø: ≥ 740 mm
Grouting pipe d 32 (internal Ø, lengths)	Lengths: as needed Internal Ø: ≥ 740 mm	Lengths: as needed Internal Ø: ≥ 740 mm

*The specified values are valid at 23 °C (+/- 2 °C) and 50% humidity

Accessories (optional)

- Spacer, 4-section for probe pipes
- Electro-welding joints
- Electro-welding angles
- Electro-welding T-pieces
- Y-piece 32-32-40 for merging



GWE OptiFlow® N

Product description

Heat transfer fluid with antifreeze additives (monoethylene glycol) and corrosion inhibitors for use in geothermal systems.



Product characteristics

- The product offers antifreeze protection up to -50 °C. Adjustable depending on the concentration used
- Free of nitrates, phosphates, amines and borate, classified in water hazard class 1
- For safe operation, we recommend a minimum concentration of 20% by volume of GWE Optiflow® N

Benefits

The corrosion inhibitors offer optimal protection against corrosion, in particular there is no risk to conventional sealing materials, pipe materials and non-ferrous metals.

Key product figures

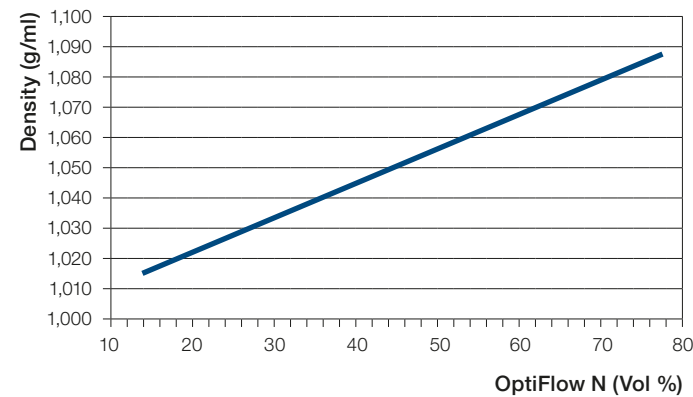
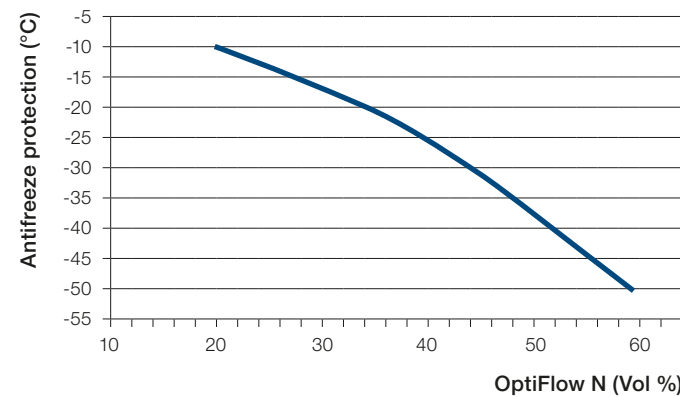

Technical data

GWE OptiFlow® N (Vol. %)	Antifreeze protection (°C)	Density (kg/l)
20%	approx. -10 °C	approx. 1,023
34%	approx. -20 °C	approx. 1,039
44%	approx. -30 °C	approx. 1,050
52%	approx. -40 °C	approx. 1,059
60%	approx. -50 °C	approx. 1,068

Delivery format

- 30 kg (26.8 l) plastic canister
- 1,000 kg (~ 900 l) IBC tank

Accessories

		
Y piece for geothermal probe DA 32 – 32 – 40 DA 40 – 40 – 50	Centering devices for geothermal probes d 32	Probe weight Weight: 12; 25; 40 kg
		
Electro-welding reductor d 25 to d 50	Electro-welding joint d 25 to d 50	Electro-welding bends 90° d 25 to d 50



10. PE pipe systems

Specialist knowledge	242
Rods and coils for drinking water	244
GWE PEHD screens and casings	245

Polyethylene as a reliable material in drinking water supply

Nowadays, water supply is inconceivable without plastic pipes made of polyethylene (PE). Due to their material technology, PE pipes offer decisive benefits in the construction and operation of buried horizontal water supply grids compared to other materials and pipe systems.

Our pipes are manufactured according to the standards DIN 8074/75, DIN EN 12201, DVGW GW335 and KTW-BWGL. The strict requirements imposed on PE pipe systems are audited by continual external monitoring by accredited testing institutions and demonstrated by corresponding certificates.

Particularly, the benefits include:

- Durability
- Corrosion resistance to aggressive soils and media
- Low weight
- Smooth internal pipe walls – no incrustations and pressure losses
- Tear-resistance
- Versatile and reliable connection technology

Apart from the previously described range of products for pipeline construction, we also produce screen pipes and casings made of PE for installing horizontal drainage or water well construction. These pipes typical have trapezoidal thread connections for rapid installation on site.

GWE PE pipes correspond to the highest quality standards and ensure safe transport of water and other media.



ZERTIFIKAT

Die SKZ - Testing GmbH verleiht der unten stehenden Firma das Recht zur Führung des SKZ Prüf- und Überwachungszeichens

Zeichen-Inhaber
GWE GmbH
Moorbeerenweg 1
31228 Peine
Deutschland

Hersteller
Sonde: GWE GmbH
Rohre: GWE GmbH
Sonderfülle: GWE GmbH

Formteile ---
Verbinder ---
Verteiler ---

Prüfrichtlinien
SKZ Prüf- und Überwachungsbestimm.
HR 3.28.2015-02

Produkt
Erdwärmesonden aus Polyethylen,
PE 100 RC, für Erdwärmeprodukte
d. s. 63 mm
bestehend aus Rohren und Sonderfülle
aus PE 100 RC, werkzeuglos geschweis.

Gültigkeitsdauer
14. April 2024

14. April 2024
Mit der Führung des SKZ Zeichens ist die Verpflichtung verbunden, bei der Herstellungs- und Prüfung der Erzeugnisse die vorgeschriebenen Bestimmungen einzuhalten.

Witzburg, 17. Februar 2022/

SKZ - Testing GmbH, Friedrich-Bergius-Ring 23, 87103 Würzburg, Germany, Tel. +49 931 4104-0, testing@skz.de

DVGW CERT
UBA Bundesrat Register

DVGW-Konformitätsbestätigung Hygiene
DVGW certificate of conformity hygiene

Konformitätsbestätigung System 1+ mit Fremdüberwachung
confirmation of conformity system 1+ with audit testing

Zertifizierthaber owner of certificate
GWE GmbH
Waltersdorfer Weg 4, D-15926 Luckau

Hersteller manufacturer
GWE GmbH
Waltersdorfer Weg 4, D-15926 Luckau

Produktart product category
Hygienische Eignung nach System 1+ - Bauteile aus Kunststoffen,
Produktgruppe P1 (1002)

Produktbezeichnung product description
Rohr aus PE-HD (PE100) mit integrierten Schichten für die
Wasserversorgung

Werkstoff/Modell material/model
PE-HD / GWE PE 100 (W1)

Prüfberichte test reports
Zertifizierungsbericht: vom 09.11.2022 (ZGW)

Prüfgrundlagen test basis
DVGW CERT ZP 1000 (05.10.2021)
UBA KTW-BWGL (07.03.2022)
UBA Übergangsregelung KTW-BWGL (10.07.2020)
DVGW W 270 (01.11.2007)

Ablaufdatum / AZ date of expiry / file no.
02.08.2027 / 22-0221-WHV

Hiermit wird bestätigt, dass die u.g. Produktbezeichnung auf der Grundlage des Zertifizierungsprogrammes DVGW CERT 1000 der zur Verfügung gestellten Produktinformationen, einschließlich der Risikosturturen und des z.B. Bewertungsbereichs die Anforderungen der unter Prüfgrundlagen genannten Normen/Gründlagen erfüllen und dass die Umwandlungsdeckschicht für den rückwärtigen Temperaturbereich erfüllt und dieser entspricht.

09.11.2022 By A-10
Dipl.-Ing. Hans-Peter K.
Leiter der Zertifizierung

DAKKS
Zentrale
Ankennungsstelle
D-30559 Hannover

DVGW CERT ist
Zertifizierungs-
Institut
10113 Berlin
Tel. +49 30 250 100
Fax +49 30 250 100 100
www.dvgw.de
info@dvgw.de

ZERTIFIKAT

Zertifizierthaber
GWE GmbH
Moorbeerenweg 1
31228 Peine
DEUTSCHLAND

Herstellerwerk
Luckau

Produkt
Druckrohre aus Polyethylen (PE) für Industrie/allgemein - PE 80, PE 100, PE 100-RC

Klassifizierung
EG 920, Außen-Durchmesser bis 160 mm

Prüfgrundlage(n)
DIN 8074:2011-12
DIN 8075:2018-08
DIN EN ISO 15494:2021-05
DIN EN 12201-1:2011-11
DIN EN 12201-2:2013-12
Zertifizierungsprogramm Kunststoffrohrsysteme (Druckrohre und -formstücke) (2017-05)

Konformitätszeichen

Registernummer
P1R0049

Gültig bis
2027-12-31

2022-04-13
Rainer Zorn M.Sc.
Geschäftsführer

DIN CERTCO Gesellschaft für Konformitätsbewertung mbH · Altonaerstraße 14 · D-22103 Berlin · www.din-certco.de

Rods and coils for drinking water RC Control pipe system

Product description

GWE RC control pipes are extruded pipes made of modern, PE 100 RC stress cracking resistant materials. They are specially designed for sandbed-free installation and are suitable for laying using ploughing or milling installation techniques as well as for relining measures. They can be homogeneously joined together using a butt welding technique or electrofusion sockets.



Product characteristics

- Material: PE 100 RC
- Applications: Drinking water (black with blue outer layer)
- Laying methods: Open in sand bed, open without sand bed, ploughing/milling in, relining, tight in pipe (close fit), Swagelining
- Standards: DIN 8074/75, DIN EN 12201, DVGW GW335, PAS1075
- External monitoring by Applus-IMA Materialforschung und Anwendungstechnik GmbH and Hessel Ingenieurtechnik GmbH

Benefits

- Service life > 100 years
- No corrosion
- Very good hydraulic properties
- Not sensitive to incrustation
- Good chemical resistance
- High impact strength
- High flexibility
- Very good weldability
- Long and flexible delivery form
- Low weight
- Resistance to slow crack growth

Models

External Ø	SDR 17	Weight kg/m	SDR 11	Weight kg/m	Pipes per pallet	Coils m
32	2.0	0.198	3.0	0.282	358	50-250
40	2.4	0.299	3.7	0.434	319	50-250
50	3.0	0.458	4.6	0.673	215	50-250
63	3.8	0.728	5.8	1.060	140	50-250
75	4.5	1.030	6.8	1.480	68	50-250
90	5.4	1.470	8.2	2.140	53	50-200
110	6.6	2.190	10.0	3.180	43	50-200
125	7.4	2.790	11.4	4.120	38	50-150
140	8.3	3.500	12.7	5.130	33	-
160	9.5	4.570	14.6	6.740	17	-
180	10.7	5.770	16.4	8.510	14	-

Rods can be delivered in lengths of 6 m or 12 m. Other section lengths available by request.

Coils can be delivered in lengths of 50 m or 100 m.

Alternative wall strengths of SDR 7.4 to SDR 26 are possible

GWE PEHD screens and casings

Product description

The GWE PEHD filter pipes and casings feature additional resistance characteristics compared with PVC-U and can be used at depths up to 60 m when dimensioned accordingly.

Product characteristics

- Material: PE 100
- Thread: TNA thread
- Structural length: 1.0 – 4.0 m as fixed length, incl. thread connection

Benefits

- Long service life
- No corrosion
- Good chemical resistance

Models

External Ø	Wall thickness	Weight kg/m	Slot widths mm
63	5.8	1.06	0.5 – 0.75 – 1.0 – 1.5 – 2.0
75	6.8	1.48	0.5 – 0.75 – 1.0 – 1.5 – 2.0
90	8.2	2.14	0.5 – 0.75 – 1.0 – 1.5 – 2.0
	5.4	1.39	
110	10.0	3.18	0.75 – 1.0 – 1.5 – 2.0 – 3.0 – 5.0 – 10.0
	6.6	2.08	
125	11.4	4.12	0.75 – 1.0 – 1.5 – 2.0 – 3.0 – 5.0 – 10.0
	6.6	2.66	
140	12.7	5.13	0.75 – 1.0 – 1.5 – 2.0 – 3.0 – 5.0 – 10.0
	8.3	3.34	
160	14.6	6.74	1.0 – 1.5 – 2.0 – 3.0 – 5.0 – 10.0 – 12.0
	9.5	4.35	









11. Hand and solar pumps

Product overview	248
Specialist knowledge	250
Hand pumps	252
Emergency hand pump KARDIA® 2000	258
GWE solar pumps	261



Access current information about
the product area online

Hand and solar pumps

	HP-GWE pb MarkII	Kardia® 2000	Aquasolar	Emergency pump Kardia® 2000	GWE solar pumps
Product					
Product type	Deep-piston hand pump with galvanized water tank and maintenance-free pump handle bearing with a stroke length of 125 mm	Hand pump with galvanized pump housing and stainless steel water tank as well as maintenance-free pump handle bearing with a stroke length of 150 mm	Solar and hand-operated pump with galvanized water tank. Designed for pressure transport, handle length 125 mm	Models: One-hand pump Two-hand pump with stainless steel water tank as well as maintenance-free pump handle bearing with a stroke length of 150 mm	Complete system: Pump Photovoltaic module Control box
	Well diameter starting from DN 80	Well diameter starting from DN 80	Well diameter starting from DN 80	Well diameter starting from DN 250	Well diameter starting from DN 80
Application	Water supply in rural areas	Water supply in rural areas	Water supply in rural areas Garden irrigation Agriculture Public buildings	Designed for emergency water supply in the event of an emergency	Network-independent water production
Product benefits	Complete independence from energy supply Corrosion-free riser pipes made of stainless steel qualities or PVC	Complete independence from energy supply Corrosion-free riser pipes made of stainless steel qualities or PVC	Complete independence from fossil energy CO ₂ neutral hybrid pump	Complete independence from energy supply Corrosion-free riser pipes made of stainless steel or PVC Two independently mounted pump stands Flood-safe emergency water supply (up to 30 cm)	Low-maintenance permanent magnet motor 100% supply security Easy installation

GWE off-grid hand and solar pumps

Hand and emergency pumps

The hand pumps presented in this product segment are deep-piston hand pumps which can also pump water up to a depth of 100 m in contrast to our familiar garden pumps. These pumps are largely product developments by GWE and have been used for several decades as part of development projects for water supply in rural areas, including in Africa.

Inspired by the robust design and durability of this pump system, even under extreme conditions, we further developed these pumps for emergency water supply in our cities and regions. Apart from antifreeze and flood protection, the focus for emergency water supply is predominantly on rapid readiness for use. The hand and emergency pumps from GWE also offer off-grid, energy-independent water supply even with deep groundwater levels. For conversion of emergency wells to operation with one-hand and two-hand pumps, we offer project-specific conversion kits.

Other benefits:

- Use of rustproof or corrosion-protected materials
- Easy installation on site
- Maintenance-free operation through the use of low-wear components
- High hydraulic efficiency
- Design as one-hand or two-hand pump (emergency pump)
- Conversion of existing emergency pumps to off-grid and energy-independent pumps

Solar pumps

GWE solar pumps are the ideal water supply solution for many private and professional applications. The connected photovoltaic modules provide the pump with its power supply and thus enable water production independently of the mains. The areas of application range from private and agricultural irrigation to water supply for small communities/operations. The supplied control box ensures electronic stabilization of the voltage and always operates the pump at the optimum operating point. The optional 230 V AC connection ensures complete power supply security, even when the sun is not shining.



Hand pump KARDIA® 2000

Product description

Corrosion-resistant hand pump system designed for rural water supply.

Product characteristics

- Galvanized pump housing
- Stainless steel water tank
- Enlarged water outlet
- Enhanced stroke limitation
- Low-maintenance pump lever bearing
- Corrosion-free riser pipes made of stainless steel or PVC
- Suitable for well diameter starting from DN 80
- Complete independence from energy supply



Cylinder types

Cylinder	VA5OKRS/VA50ERS	K65KRS/VA65ERS	K80KRS
Minimum diameter of the well (inside)	80 mm	100 mm	115 mm
Maximum installation depth	60 m	45 m	15 m
Pumping rate at max. stroke (150 mm)	0.27 l	0.44 l	0.75 l
Pumping rate at strokes/min.			
	40	651 l/h	1,066 l/h
	50	814 l/h	1,333 l/h
60	976 l/h	1,600 l/h	2,712 l/h
Hydraulic efficiency	90%	90%	90%

Dimensions

Piston diameter	50 mm	62 mm	78 mm
Length with screen approx.	1,185 mm	1,130 mm	900 mm
Maximum external diameter	73 mm	90 mm	106 mm
Slot width of the screen	0.5 mm	0.5 mm	0.5 mm

Materials

Riser pipe connection	Stainless steel	PVC/stainless steel	PVC
Cylinder	Stainless steel	PVC/stainless steel	PVC
Foot valve housing	Stainless steel	PVC/stainless steel	PVC
Piston	POM/stainless steel	POM/stainless steel	POM/stainless steel
Valve plates	EPDM/PU	EPDM/PU	EPDM/PU
Screens	PVC	PVC	PVC
Nuts and screws	Stainless steel	Stainless steel	Stainless steel
Weight, complete approx.	3.3 kg/3.3 kg	3.6 kg/4.4 kg	4.5 kg



Pump riser pipe system

SBF-KATUR® (PVC)

Corrosion-free pump riser pipe system made of PVC with double spigot socket connection in accordance with GWE company standard.

- Pipes with trapezoidal thread on both sides
- Double spigot sockets with inserted sealing elements
- Pre-mounted pump rod with M12 thread connection
- equipped with guide elements, lock nuts and long nuts
- Standard structural length 3 m (Structural lengths 0.5 and 1.0 m on request)

Materials

- Riser pipe, double spigot socket: PVC
- Rod/rod guides: Stainless steel/synthetic rubber
- Long nuts and lock nuts: Stainless steel
- Weight, complete approx. 2.5 kg/running meter

Dimensions

- Pipe diameter: 48 mm
- Pipe wall thickness: 8 mm
- External diameter double spigot socket: 70 mm
- Rod diameter: 10.8 mm

Riser pipe system stainless steel

Corrosion-free pump riser pipe system made entirely of stainless steel in accordance with GWE company standard.

- Pipes with welded connection elements with pipe thread
- Pre-mounted pump rod with M12 thread connection
- equipped with guide elements, lock nuts and long nuts
- Standard structural length 3 m (0.5 and 1 m on request)

Dimensions

- Pipe diameter: 38 mm
- Pipe wall thickness: 2 mm
- External diameter double spigot socket: 50 mm
- Rod diameter: 10.8 mm



Pump body

Pump body complete, consisting of:

- Pump housing Kardia® 2000
- Water tank
- Water outlet
- Pump lever with flange bearing
- Joint head for pump rods

Anchoring set Kardia® 2000

- Anchor frame Kardia 190 x 280 CIEH
- Stone bolts M16

Materials

- Pump housing and cover hood: Galvanized steel
- Water tank and water outlet: Stainless steel
- Pump lever/bolt: Galvanized steel/stainless steel
- Joint head with rod connection: Stainless steel
- Mounting material (nuts, screws): Stainless steel

Dimensions

- Pump housing L x W x H: 260 x 180 x 1,010 mm
- Base frame L x W x H: 400 x 320 x 10 mm
- Axle distance of boreholes L x W: 350 x 250 mm
- Diameter of boreholes: 20 mm
- Weight, complete: approx. 53 kg

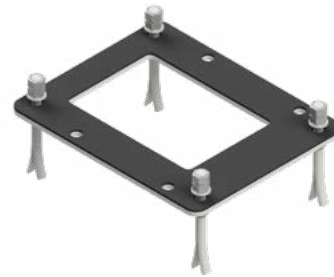

GWE aquasolar

Product characteristics

Solar-powered hand pump system designed for rural water supply, schools, hospitals, gardens...

- Up to 10 m³ water per day
- Robust and reliable
- Easy installation and safe handling, fast commissioning with Plug and Play system
- Hand pump prevents interruptions to the water supply
- Suitable for well diameter starting from DN 80

The pump consists of

- Pump body
- Drive unit
- Riser pipes made of stainless steel or PVC
- Cylinder made of stainless steel or PVC



Cylinder types

Cylinder	VA40ERS	VA50KRS/ VA50ERS	K65KRS/ VA65ERS	K80KRS
Minimum diameter of the well (inside)	80 mm	80 mm	100 mm	115 mm
Max. installation depth	81 m	60 m	45 m	27 m
Pumping rate at max. stroke (120 mm)	0.15 l	0.24 l	0.37 l	0.57 l
Pumping rate at strokes/min.				
40	362 l/h	565 l/h	898 l/h	1,376 l/h
50	452 l/h	707 l/h	1,122 l/h	1,720 l/h
60	543 l/h	848 l/h	1,347 l/h	2,064 l/h
Dimensions				
Piston diameter	40 mm	50 mm	63 mm	78 mm
Length with screen approx.	1,220 mm	1,185 mm	1,130 mm	900 mm
Maximum external diameter	63 mm	73 mm	90 mm	106 mm
Slot width of the screen	0.5 mm	0.5 mm	0.5 mm	0.5 mm
Materials				
Riser pipe connection	Stainless steel	Stainless steel	PVC/stainless steel	PVC
Cylinder	Stainless steel	Stainless steel	PVC/stainless steel	PVC
Foot valve housing	Stainless steel	Stainless steel	PVC/stainless steel	PVC
Piston	PVC/stainless steel	POM/stainless steel	POM/stainless steel	POM/stainless steel
Valve plates	EPDM	EPDM/PU	EPDM/PU	EPDM/PU
Screens	PVC	PVC	PVC	PVC
Nuts and screws	Stainless steel	Stainless steel	Stainless steel	Stainless steel
Weight, complete approx.	2.6 kg	3.3 kg	3.6 kg/4.4 kg	4.5 kg

Installation depth possible up to 100 m by request



Pump riser pipe system

SBF-KATUR® (PVC)

Corrosion-free pump riser pipe system made of PVC with double spigot socket connection in accordance with GWE company standard. For use with the cylinder K80KRS, K65KRS, VA50KRS

- Pipes with trapezoidal thread on both sides
- Double spigot sockets with inserted sealing elements
- Pre-mounted pump rod with M12 thread connection
- equipped with guide elements, lock nuts and long nuts
- Standard structural length 3 m (Structural lengths 0.5 and 1.0 m on request)
- Installation depth depending on cylinder type

Materials

- Riser pipe, double spigot socket: PVC
- Rod/rod guides: Stainless steel/synthetic rubber
- Long nuts and lock nuts: Stainless steel
- Weight, complete approx. 2.5 kg/running meter

Dimensions

- Pipe diameter: 48 mm
- Pipe wall thickness: 8 mm
- External diameter double spigot socket: 70 mm
- Rod diameter: 10.8 mm

Riser pipe system stainless steel

Corrosion-free pump riser pipe system made entirely of stainless steel in accordance with GWE company standard.

- Pipes with welded connection elements with pipe thread
- Pre-mounted pump rod with M12 thread connection
- equipped with guide elements, lock nuts and long nuts
- Standard structural length 3 m

Dimensions

- Pipe diameter: 38 mm
- Pipe wall thickness: 2 mm
- External diameter over the spigot socket: 50 mm
- Rod diameter: 10.8 mm



Pump body

Pump body complete, consisting of:

- Pump housing
- Water tank with outlet
- Pump foot with inspection flap
- Pump lever with flange bearing

Dimensions

- Pump housing L x W x H: 360 x 300 x 1170 mm
- Base frame L x W x H: 360 x 300 x 10 mm
- Axle distance of boreholes L x W: 280 x 195 mm
- Diameter of boreholes: 20 mm
- Weight, complete: approx. 56 kg

Materials

- Pump housing: Galvanized steel
- Water tank and water outlet: galvanized
- Pump lever: Galvanized steel/stainless steel
- Rod connection galvanized
- Mounting material (nuts, screws): galvanized

Drive unit

- Support frame
- Engine IP65
- Cable 20 m 3 x 2.5 mm²
- Flywheel
- Solar panel
- Control device

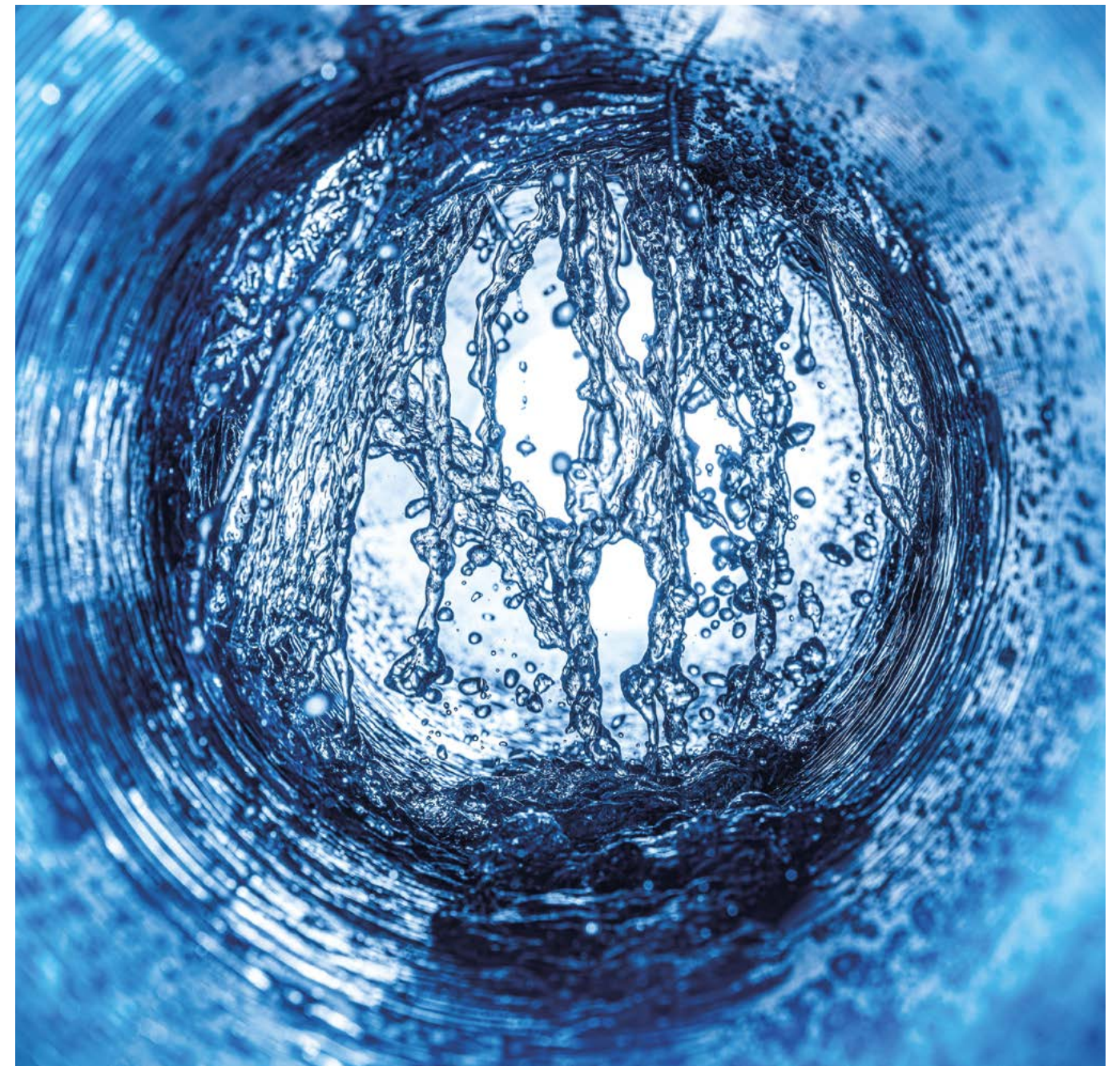

Emergency hand pump KARDIA® 2000

Product description

Corrosion-resistant hand pump system designed for emergency water supply.

Product characteristics

- Galvanized pump housing
- Stainless steel water tank
- Enlarged water outlet
- Enhanced stroke limitation
- Low-maintenance pump lever bearing
- Riser pipe remains in the well even if the housing is not mounted
- Complete independence from energy supply
- Two independently mounted pump stands
- Corrosion-free riser pipes made of stainless steel or PVC
- Suitable for well diameter starting from DN 250
- Flood-safe emergency water supply (up to 30 cm)



Cylinder types

Cylinder	VA50KRS/VA50ERS	K65KRS/VA65ERS	K80KRS
Minimum diameter of the well (inside)	80 mm	100 mm	115 mm
Maximum installation depth	60 m	45 m	15 m
Pumping rate at max. stroke (150 mm)	0.27 l	0.44 l	0.75 l
Pumping rate per cylinder at strokes/min.			
40	651 l/h	1,066 l/h	1,808 l/h
50	814 l/h	1,333 l/h	2,260 l/h
60	976 l/h	1,600 l/h	2,712 l/h
Hydraulic efficiency	90%	90%	90%
Dimensions			
Piston diameter	50 mm	62 mm	78 mm
Total structural length with screen approx.	1,185 mm	1,130 mm	900 mm
Maximum external diameter	73 mm	90 mm	106 mm
Slot width of the screen	0.5 mm	0.5 mm	0.5 mm
Materials			
Riser pipe connection	Stainless steel	PVC/stainless steel	PVC
Cylinder	Stainless steel	PVC/stainless steel	PVC
Foot valve housing	Stainless steel	PVC/stainless steel	PVC
Piston	POM/stainless steel	POM/stainless steel	POM/stainless steel
Valve plates	EPDM/PU	EPDM/PU	EPDM/PU
Screens	PVC	PVC	PVC
Nuts and screws	Stainless steel	Stainless steel	Stainless steel
Weight, complete approx.	3.3 kg/3.3 kg	3.6 kg/4.4 kg	4.5 kg



Pump riser pipe system

SBF-KATUR® (PVC)

Corrosion-free pump riser pipe system made of PVC with double spigot socket connection in accordance with GWE company standard.

- Pipes with trapezoidal thread on both sides
- Double spigot sockets with inserted sealing elements
- Pre-mounted pump rod with M12 thread connection
- equipped with guide elements, lock nuts and long nuts
- Standard structural length 3 m (Structural lengths 0.5 and 1.0 m on request)

Materials

- Riser pipe, double spigot socket: PVC
- Rod/rod guides: Stainless steel/synthetic rubber
- Long nuts and lock nuts: Stainless steel
- Weight, complete approx. 2.5 kg/running meter

Dimensions

- Pipe diameter: 48 mm
- Pipe wall thickness: 8 mm
- External diameter double spigot socket: 70 mm
- Rod diameter: 10.8 mm

Riser pipe system stainless steel

Corrosion-free pump riser pipe system made entirely of stainless steel in accordance with GWE company standard.

- Pipes with welded connection elements with pipe thread
- Pre-mounted pump rod with M12 thread connection
- equipped with guide elements, lock nuts and long nuts
- Standard structural length 3 m (0.5 and 1 m on request)

Dimensions

- Pipe diameter: 38 mm
- Pipe wall thickness: 2 mm
- External diameter over the spigot socket: 50 mm
- Rod diameter: 10.8 mm



Installation depth possible up to 100 m by request

Pump body

Pump body complete, consisting of:

- Pump housing Kardia® 2000
- Water tank
- Water outlet
- Pump lever with flange bearing
- Joint head for pump rods

Well head with protective pipe

Protective pipe diameter DN 400

- Cover plate 300 x 600 mm
- Theft protection (special screws)
- Rainwater-tight base plates sealing of well
- Drive-over loading class ≥ B 125

Materials

- Pump housing and cover hood: Galvanized steel
- Water tank and water outlet: Stainless steel
- Pump lever/bolt: Galvanized steel/stainless steel
- Joint head with rod connection: Stainless steel
- Mounting material (nuts, screws): Stainless steel
- Well head with protective pipe: Galvanized steel

Dimensions

- Pump housing L x W x H: 260 x 180 x 1,010 mm
- Base frame L x W x H: 400 x 320 x 10 mm
- Axle distance of boreholes L x W: 350 x 250 mm
- Diameter of boreholes: 20 mm
- Weight, complete: approx. 53 kg



GWE solar pumps

Product description

Complete system for water supply.
Network-independent water supply

Benefits

- For small well diameters from 3"
- Water production without power grid
- Stainless steel pump with wear-resistant polycarbonate hydraulics or stainless steel
- Low-maintenance permanent magnet motor
- Integrated dry-run protection
- 100 % power supply security with additional 230 V AC power connection
- Connection for float switch
- Easy installation

Pump

The pump body in 3" and 4" size is made of stainless steel AISI 304 (V2A). The impeller and individual stages of the pump hydraulics are made of wear-resistant polycarbonate plastic or stainless steel.



GWE solar pumps 3"

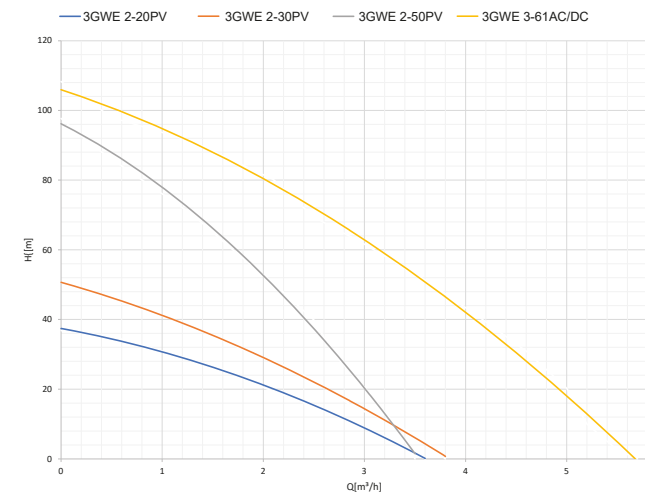

GWE solar pumps 3"

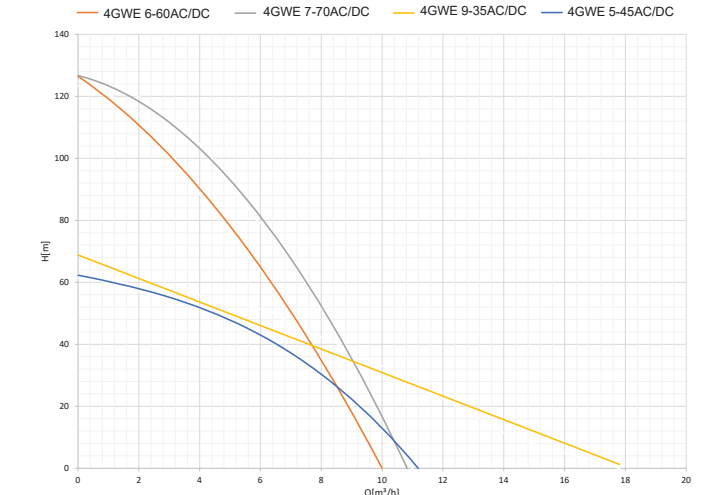

Technical data

Model	Yield (m ³ /h)	Pump head (m)	Power (W)	Rp"	Input voltage (V)	max. open-circuit voltage (V)	Number of PV modules 540 W
3GWE 2-20PV	2	20	300	1.25"	30-48	<60	1
3GWE 2-30PV	2	30	400	1.25"	60-90	<100	2
3GWE 2-50PV	2	50	750	1.25"	90-120	<200	3
3GWE 3-61AC/DC	3	61	1,100	1.5"	110-150	<200	3
4GWE 5-45AC/DC	5	45	1,500	2"	200-280	<430	6
4GWE 6-60AC/DC	6	60	2,200	2"	260-380	<430	8
4GWE 7-70 AC/DC	7	70	2,800	2"	260-380	<430	8
4GWE 9-35 AC/DC	9	35	2,200	2"	260-380	<430	8

Other pump types available by request

Control box AC/DC

The control box is the energy and switching center of GWE solar pumps. The PV modules of the solar generator and the back-up power supply with AC connection are connected here. If there is no direct sunlight, the control electronics automatically switch to AC operation if required. The control box features insulation protection class IP 65 and is equipped with extensive protective devices.

- Low / high voltage protection
- Over-current protection
- Short-circuit protection



Max. power	up to 2.8 kW
DC input voltage	80-420 V DC
AC input voltage	75-280 V AC
Max. AC current	20 A
Max. DC current	12 A
Operating temperature	-15-60 °C

Complete system

- Solar pump with 2 m cable, longer cables are available if required
- Control box
- Float switch
- MC4 PV cable connector
- Teflon tape
- Screwdriver
- Pipe clamp
- Water supply connection

Optionally:

- Riser pipes DN 40 (PE, PVC, stainless steel)
- Well head (PVC, stainless steel)
- Stainless steel security cable
- Connection box
- Solar modules
- Solar mast



Germany: Agricultural irrigation



Burkina Faso: Water supply in rural areas



Senegal: Water supply in rural areas



12. Irrigation

Agricultural irrigation	266
Garden irrigation - Rain Bird	268



Access current information about
the product area online

Agricultural irrigation by GWE – from the spring to the root, all from a single source

Drip irrigation is an irrigation method in which the water is delivered directly to the plants in a controlled manner. This method involves the use of drip hoses that contain small holes through which the water drops into the soil slowly and evenly. In contrast to conventional irrigation methods, for which the water is distributed across the entire area, drip irrigation supplies water and nutrients to the plant roots in a targeted manner. This achieves high water efficiency with top quality and high yields.

Drip irrigation is suitable for a variety of crops and plant types. This irrigation method is particularly well suited for row crops and special crops such as asparagus, vegetables, strawberries, fruit trees, berry bushes, hops, herbs, wine grapes and ornamental plants. Drip irrigation can also be highly economically effective for field crops such as corn, potatoes, onions and alfalfa. However, it is important to adapt the irrigation to the specific requirements of each crop, including the soil type, planting density and water needs. Furthermore, drip irrigation can also be used for greenhouse crops such as cucumbers, peppers and tomatoes as well as for hydroponics.

Benefits of drip irrigation

- Energy-efficient: Drip irrigation only requires low pressure of approx. 2 bar from the pump and is thus very energy-saving.
- Water-conserving: the water is distributed directly to the plant root in small but regular doses. No loss due to evaporation, wind drift and infiltration
- Fertigation: along with the irrigation water, soluble or fluid fertilizer can be administered in drips as needed. This improves quality and yield with a minimal use of nutrients.
- Healthier plants: In contrast to irrigation, the leaves stay dry and air humidity is low, which has a positive effect against leaf diseases.
- Less weed pressure: for rows and ridge crops, the in-between areas and ridge flanks remain dry, so that weeds are not also supplied with water.

Our range of services

We are available to assist your projects with professional advice, take charge of the complete planning process and offer the entire range of products that are required for a successful irrigation system. Our services extend all the way to automation with smart technology such as remote control of pumps and valves/sectors via app, soil moisture sensors or satellite-based irrigation recommendations.

Consulting and design

Overall, the design of a drip irrigation system requires thorough planning and coordination of the different factors in order to ensure efficient and successful irrigation. Together with you, we will find the optimal and most economical solution for your operations based on the specific site.



Coordinated material for all application scenarios

As a Rivulis distribution partner, we offer drip hoses, single drippers, sprinklers, filters, layflat hoses, fittings and control valves from a single source. The Israeli company Rivulis is a worldwide leader in the area of micro-irrigation and provides high-quality products that are proven effective.

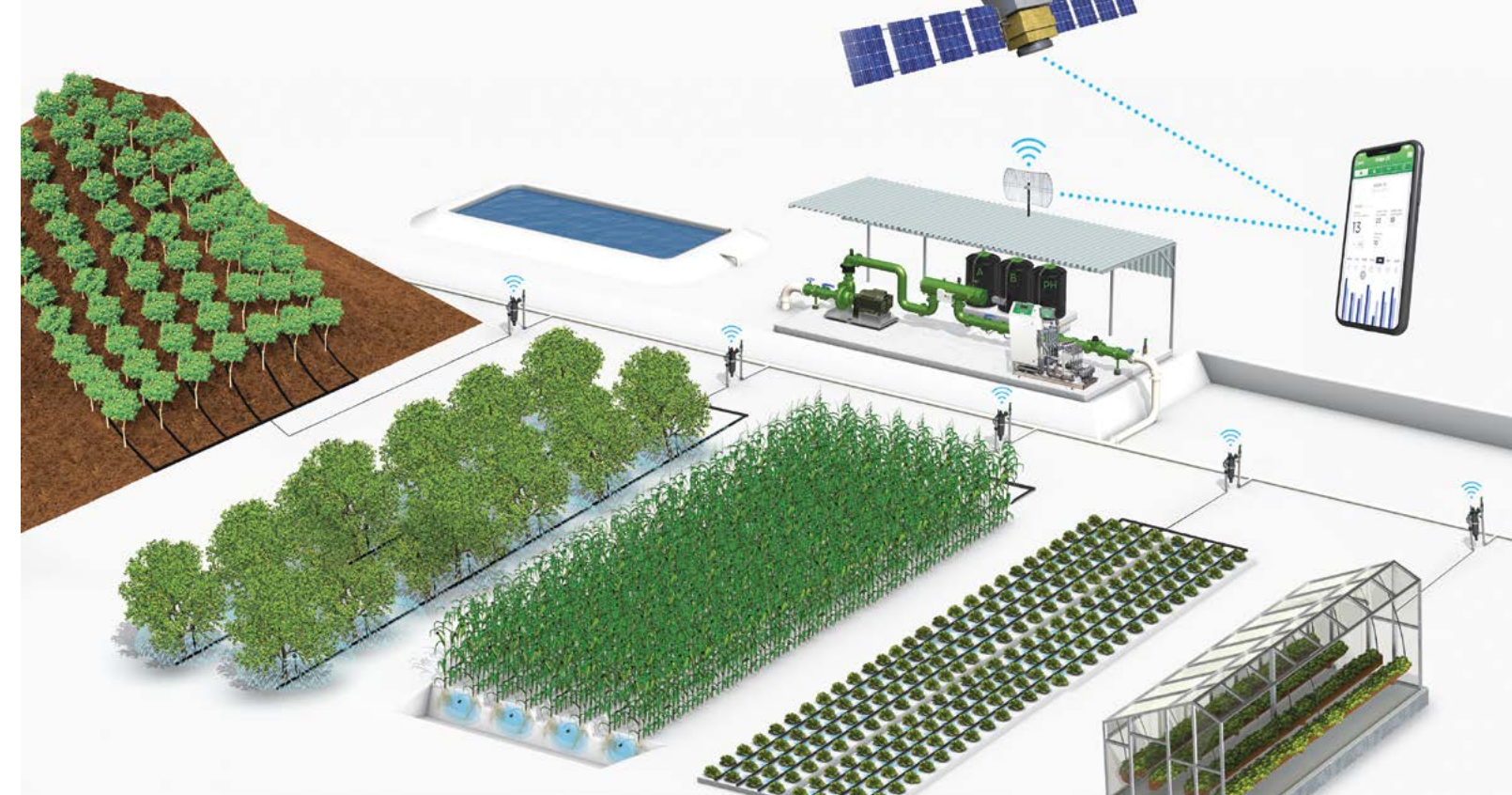

Schematic layout of various drip irrigation systems with interfaces for smart technology

Drip hoses

Regardless of whether they are seasonal or multi-year, pressure-sensitive or pressure-compensated, suspended, laid, minimally buried or permanently buried as part of a system, we have the right hoses for your intended use.



Hydraulic control valves

Control valves take care of important functions such as protecting the material against excess pressure, pressure stop functions for automatically flushing filters and as a precisely adjustable pressure reducer and on/off valve for controlling centers and adjusting the pressure to the drip hoses.



Filters

Filters are the centerpiece of a drip irrigation system. Without filters suitable for the water quality, there is a risk that the drip hoses will become clogged sooner or later. We have solutions for all flow rate volumes, various degrees of automation and sieve and disc filters as well as media filter.



Further detailed information and prices for additional accessories such as layflat hoses, microfittings, controls and instruments, smart technology from Solem with networked weather stations, control modules and sensors or for satellite-based irrigation recommendations Manna, can be found on our homepage at www.irri360.com.

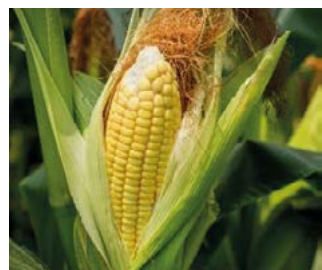

Garden irrigation – Rain Bird



Product description

Your automatic irrigation can be as simple or complex as you like. That entirely depends on the landscape conditions, the selected degree of automation, and the total amount of water you would like to save.

An automatic irrigation system uses a control device to determine a schedule for irrigating your site. Based on the schedule, the control device opens your valve, causing water to flow into the sprinkler heads or drippers.

At the scheduled end time, the control device closes the valve and stops the flow of water until the next scheduled start.

In contrast to hand-operated irrigation systems, an automatic irrigation system gives you greater control over when water is used, as well as the volume and frequency. With an automatic irrigation system from Rain Bird, your green space will be optimally maintained over the long term.



Benefits

The benefits of an automatic irrigation system ultimately lie in the beautiful green spaces, gardens and landscapes that you can create and maintain with constant and reliable irrigation. Green spaces, parks and gardens increase the value of real estate and make shopping centers and commercial centers more visually appealing.

- A precise quantity of water is dispensed in order to prevent insufficient or excessive irrigation

- Plant health is maximized and investments in trees and landscaping are protected
- Reduces labor costs by eliminating manual irrigation
- Lowers safety risks due to excessive irrigation
- Ensures efficient water usage and helps to achieve water-saving targets
- Helps with the maintenance of public green spaces and parks
- Saves water, energy and money thanks to efficiency

Individual components in the Rain Bird irrigation system

Irrigation control devices for landscaping with residential and commercial use

All Rain Bird control devices simplify the operation of your irrigation system with flexible functions for the automation of irrigation. Rain Bird offers you control devices for residential or basic commercial purposes with battery operation and WiFi connection tailored to your project objectives and budget, as well as accessories that maximize your water savings.



Valves for optimal performance

A valve is like a water tap. Valves react to commands from the control device. When valves receive a signal to open, water flows to the sprinklers. When they receive another signal to close, the flow of water stops. Rain Bird's industry-leading valves are renowned for their constant and faultless performance. Rain Bird has a valve for every application in landscaping.



Sprinklers and nozzles for reliable output

Reliability and user-friendly operation are just two of the many reasons why Rain Bird sprinklers and nozzles are used in irrigation systems worldwide. The Rain Bird technology produces larger water droplets and more uniform coverage to maximize water savings. Rain Bird sprinklers are ideal for use in parks, on sports fields and other large lawn areas. The comprehensive range of Rain Bird nozzles offers options for every application and every budget.



Low-volume drip irrigation

Drip irrigation is a low-volume irrigation method that distributes water slowly and directly to the plant's roots to achieve maximum efficiency. Rain Bird offers an extensive range of water-saving accessories for low-volume and drip irrigation which are perfectly suited for flowerbeds, planted areas, trees, shrubs and lawns.



You can find more detailed information and prices on our home page at www.gwe-group.com.



13. Installation accessories

We have an extensive range of installation accessories.

You can find the various models of fittings, valves, screw fittings and other installation materials from our price lists at www.gwe-group.com or by contacting our experienced sales representatives from the DACH sales team (gwe-group.com).



14. Services

Specialist knowledge	274
Design calculations	274
Flushing service	274
Installation service	274
3D design	274
Pump service	275
Training based on W 120	275
Stainless steel staining plant	275

Services

Design calculations

For practical support, GWE offers design calculations for various well screen and casing types made of steel and plastic.

 Auslegungsberechnung NORESTA DN 400			
Rohrdaten:			
Außendurchmesser	D _a	450,00	mm
Wandstärke	s _w	23,50	mm
Verbindungsart	Verb	NORESTA	
Außendurchmesser der Muffe	d ₃	500,00	mm
Innendurchmesser des Rohres	d ₁	403,00	mm
Rohrgewicht pro Meter	G	51,00	kg/m
Spez. Gewicht d. Rohrwerkstoffes	g ₁	1,40	kg/dm ³
Elastizitätsmodul	E	2750,00	N/mm ²
zul. Zugspannung	s _{zul.}	18,00	N/mm ²
zul. Vergleichsspannung	s _{v.zul.}	10,00	N/mm ²
Bohrlochdaten:			
Tiefe der Rohrtour	h _{Rohr}	69,00	m
Statischer Wasserspiegel	h _{stat.}	0,00	m
Spez. Gew. der Spülung	g ₂	1,00	kg/dm ³
Schüttgewicht des Filterkieses	g ₃	1,50	t/m ³
Porenvolumen des Filterkieses (25-47%)	v _p	35,00	%
Druckbelastungen:			
max. zul. Innendruck	P _i	1,10	N/mm ²
max. zul. Außendruck	P _{ext.}	1,10	N/mm ²
(max. zul. Außendruck Filterrohr)	P _{ext.}	0,85	N/mm ²
auftretende Außendrucke:	P _K	0,58	N/mm ²
	P _E	0,58	N/mm ²
	h _{max}	131,87	m
max. Einbautiefe (Vollwandrohr)			
Zugbelastung:			
max. zul. Zugbelastung Vollwandrohr	F _{max.}	110,00	kN



Installation service

Special materials also require special treatment. To fully make use of the benefits of GWE products, we offer an installation service on site for a variety of our products. In this way, we can provide practical instruction for your specialist personnel concerning the proper handling of our products and ensure smooth installation.

3D design

Whether standard or unusual custom solutions, our design team will find a solution for every challenge. The engineers work at CAD workstations with the latest equipment and Autodesk products. Designs are created in collaboration with our customers. Thanks to drawings with 3-dimensional perspective, customers obtain an optimal visual overview of their project.

Flushing service

GWE relies on application technologies that are proven in the field, and offers a flushing service on site. Based on project data, flushing programs are generated. In addition, a range of analysis options are available at the in-house flushing lab. Individual training opportunities pursuant to DVGW W 116 are also offered.

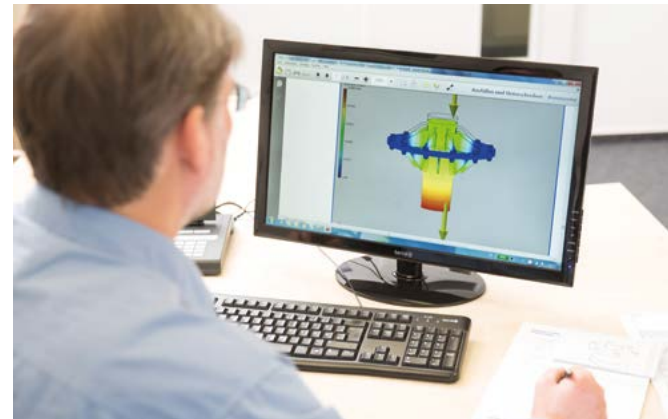

Pump service

With our specialists in pump service, we are able to perform maintenance and repairs on all submersible pump models. We offer you rapid turn-around times for analysis and repair

of your submersible pumps, regardless of the manufacturer. Furthermore, you can use our pick-up service for your defective submersible pumps.



Training based on W 120

As a complete provider for well materials, GWE offers comprehensive training in the topics of well materials, submersible motor pumps as well as flushing and sealing technology. Training can be designed on a custom basis, and oriented depending on the depth of knowledge for trainees, foremen, masters or engineers. Apart from in-house customer training, GWE also sends specialists to hold lectures and courses at external training locations, to conferences organized by specialist associations or directly to customers.



Stainless steel staining plant

Staining is absolutely the most important follow-up treatment of welded stainless steel products. Foreign metals, tarnish, slag and scale from previous production processes impede the complete formation of the invisible yet necessary passive layer without which stainless steel is not corrosion-resistant. By staining products in the dip tank, the surface imperfections mentioned above are eliminated and the passive layer is able to form on the pure metal surface under the influence of oxygen from the air.

Staining is the basic prerequisite that ensures a long service life for our stainless steel products. At our in-house staining plant, we fulfil all necessary metallurgical and environmental requirements. This process gives stainless steel its value. The quality of our contract staining plant is highly appreciated by many of our partners.





GWE GmbH
Moorbeerenweg 1
31228 Peine, Germany
Phone: +49 5171 294-0
info@gwe-gruppe.de
www.gwe-gruppe.de

Materials and specifications are subject to change without notice. Illustrations may include optional equipment and not show all possible configurations. These and the technical data are provided as indicative information only, with any errors and misprints reserved.